

Cr.ucdavis.edu



**COMMUNICATIONS
RESOURCES**
UCDAVIS

**TELECOMMUNICATIONS
STANDARDS**

Published
JANUARY 2006

Foreword

Approval of this Standard

- This manual is published by the Engineering and Construction Management (ECM) office, Communications Resources, University of California Davis, for use by the UC Davis Architects and Engineers (A&E) and their design consultants.

Documents Superseded

- This standard replaces the CR Telecommunications Standards dated January 2005 in its entirety.

Significant Administrative and Technical Changes from the Previous Edition

Table of Contents

Foreword 2
Table of Contents 3
List of Tables 8
List of Figures 10

Section 1.0 Introduction 12
 1.1 About this Manual 12
 1.2 Communications Resources (CR) Responsibilities 13
 1.3 Architects and Engineers (A&E) Role 14
 1.4 Communication Consultant/Designer Role 15
 1.5 The Telecommunications Standards Design Process 15

Section 2.0 Site Construction 17
 2.1 Design Activities: 17
 2.2 Cable Distribution Methods 17
 2.3 Conduit Routes 18
 2.4 Underground Conduit Construction 18
 2.4.1 General 18
 2.4.2 Sizing Underground Conduit 21
 2.4.3 Conduit Separation Requirements 21
 2.5 Maintenance Holes (MH) and Hand Holes (HH) 22
 2.5.1 General 22
 2.5.2 Additional HH Requirements 23
 2.5.3 MH/HH Conduit Entry Requirements: 25
 2.6 Aerial Cable Requirements 26
 2.7 Project Drawings 28

Section 3.0 Architectural Requirements 29
 3.1 General 29
 3.1.1 Telecommunications Spaces (TS) 29
 3.1.2 Equipment Room (ER) 29
 3.1.3 Telecommunications Room (TR) 30
 3.2 Room Location 30
 3.2.1 Telecommunications Spaces shall: 30
 3.2.2. Telecommunications Spaces shall not: 31
 3.3 Room Sizing 32
 3.4 Room Lighting 33
 3.4.1. Lighting shall: 33
 3.4.2. Lighting shall not: 34

- 3.5 Water Infiltration..... 34
- 3.6 Fire Safety and Protection 34
- 3.7 Doors 35
- 3.8 Interior Finishes 35
 - 3.8.1 Floor 35
 - 3.8.2 Walls 36
 - 3.8.3 Ceilings 36
 - 3.8.4 Clearance..... 36
- 3.9 Telecommunications Spaces Construction Sequence..... 37
- 3.10. Special Design Considerations 37
 - 3.10.1 Slab on Grade 37
 - 3.10.2 Work Area Outlets (WAO)..... 38
 - 3.10.3 Building interfaces 38
 - 3.10.4 Walls and columns 39
 - 3.10.5 Floors 39
 - 3.10.6 Courtesy, Pay, Text, Emergency and Wheel Chair Elevator Telephones 39
 - 3.10.7 Roof 39
- 3.11 Campus Environments 40
- 3.12 Tenant Improvement Project..... 40
- 3.13 Construction Documents 40
- Section 4.0 Electrical Requirements..... 41
 - 4.1 Design Requirements 41
 - 4.2 Telecommunications Space (TS) Electrical Requirements 41
 - 4.3 Equipment Rack and Cabinet Electrical Requirements 42
 - 4.4 Electromagnetic Interference 43
 - 4.5 Emergency Back-up Power 43
 - 4.6 Grounding 43
 - 4.7 Telephone Terminal Board 44
 - 4.8 Raised Floor Bonding and Grounding..... 44
 - 4.9 TS Layout (General) 44
 - 4.10 Fire Stop Penetrations 44
 - 4.11 Communication Pathways 46
 - 4.12 Cable Support (General)..... 47

- 4.13 Work Area Outlet (WAO) 47
 - 4.13.1 WAO Density..... 47
 - 4.13.2 WAO Device Boxes..... 48
 - 4.13.3 WAO Floor Mounted Boxes..... 48
- 4.14 Interior Conduits 48
 - 4.14.1 Conduit Size..... 49
 - 4.14.2 Installed interior conduits shall: 49
 - 4.14.3. Installed conduits shall not: 51
 - 4.14.4 Structures to Support Vertically Aligned TS's..... 51
 - 4.14.5. Structures to Support Horizontally Offset TS's..... 52
- 4.15 Communications Cable Runway and Trays..... 53
 - 4.15.1 Cable Runway..... 53
 - 4.15.2 Cable Trays..... 54
- 4.16 Communications J-Hooks..... 56
- 4.17 Communication Floor Poke-Through Devices 56
- 4.18 Floor Boxes..... 57
- 4.19 Pull Boxes..... 57
- Section 5.0 Mechanical (HVAC)..... 60
 - 5.1 Design Process..... 60
 - 5.2 HVAC Requirements 60
 - 5.3 Fire Smoke Dampers..... 61
- Section 6.0 Communication Designers 62
 - 6.1. Design Process..... 62
 - 6.2. Equipment in Telecommunications Spaces 62
 - 6.3. The Horizontal Segment 62
 - 6.3.1. The Design Process 62
 - 6.3.2. The Type and Number of NAM's..... 63
 - 6.3.3. NAM Conduit, Backbox and Height Requirements..... 65
 - 6.3.4. ADA Requirements 65
 - 6.3.4. Cable Types, Colors and Lengths 66
 - 6.3.5. Termination Hardware Requirements at the WAO 68
 - 6.4. Termination Hardware Requirement in the Telecommunications Space 69
 - 6.4.1. The Design Process 69
 - 6.4.2. Termination Hardware Requirements in the ADF/BDF/IDF..... 70
 - 6.4.3. Support Hardware Requirements in the ADF/BDF/IDF 72
 - 6.4.4. Drawings for Construction/Project Managers 74
 - 6.5. Assigning the NAM numbers 75
 - 6.6. Cross Connecting Voice NAM's..... 76

- 6.7. Structures to Support the Structure (Horizontal) Cabling 76
- 6.8 Testing Requirements for Copper and Fiber Optic Horizontal Cables 79
 - 6.8.1. General 79
 - 6.8.2. UTP Horizontal Voice and Data Cable Testing 80
 - 6.8.4. FTTD Horizontal Cable Testing: 81
- 6.9. Riser Segment 84
 - 6.9.1. The Design Process 84
 - 6.9.2. The Size, Type and Termination of Copper Riser Cable 85
 - 6.9.3. The Size, Type and Termination of Fiber Optic Riser Cable 86
- 6.10. Testing Requirements for Copper and Fiber Optic Riser Cables 87
 - 6.10.1. General 87
 - 6.10.2 Copper Riser Cable Testing Requirements 87
 - 6.10.3 Fiber Riser Cable Testing Requirements 88
- 7.0 Outside Cable Plant 91
 - 7.1 General 91
 - 7.1.1. The Design Process 91
 - 7.1.2. Cable Routes 91
 - 7.1.3. Cable Distribution Methods 92
 - 7.2. Underground and Direct-buried Cable Requirements 92
 - 7.3. Cable Types 95
 - 7.3.1. Outside Plant Copper cable 95
 - 7.3.2. Outside Plant Fiber Optic cable 95
 - 7.4. Aerial Cable Requirements 96
 - 7.5. Cable Splicing Methods and Splice Closures 97
 - 7.6. Building Entrance Terminals 99
 - 7.7. Electrical Protection and Bonding/Grounding Requirements 100
 - 7.8. Testing Requirements for Outside Plant Cables 100
 - 7.9. Labeling Requirements 101
- 8.0 800 MHz IN-BUILDING RADIO SYSTEMS 102
 - 8.1. The Design Process 102
 - 8.2. General Radio Communications Coverage 102
 - 8.3. Definitions 102
 - 8.4. General 103
 - 8.5. Testing and Acceptance 105
 - 8.6. Qualifications of Testing Personnel 107
- 9.0 WIRELESS NETWORK SYSTEMS 110
- 10.0 MASTER ANTENNA TELEVISION (MATV) SYSTEM 111

- 10.1. The Design Process 111
- 10.2. The Type and Number of MATV WAO's 113
- 10.3. Cable Types and Lengths 113
- 10.4. Termination hardware requirements at the MATV WAO and BDF/IDF 113
- 10.5. Structures to Support the Horizontal Cabling 115
- 10.6. Determining the broadband distribution equipment required. 117
- 10.7. Assigning the MATV NAM numbers 119
- 10.8 Cable Testing Procedures 120
- 11.0 AUDIO-VISUAL SYSTEMS 124
 - 11.1. The Design Process. 124
 - 11.2. Performance Standards 124
- 12.0 CADD DRAWING STANDARDS 126
 - 12.1. Inside and Outside Plant Drawing Requirements 126
 - 12.2. Inside Plant (ISP) drawing requirements 130
 - 12.3. Communications Drawing Requirements for Consultants and Contractors 132
- APPENDIX A 133
 - Specifications 133
 - Specification 01 WAO Faceplates, Surface Mount Boxes, Wiremold® Adapter and Modules 134
 - Specification 02 NAM Numbering, Matrix and Labeling Requirements 137
 - Specification 03 WAO Cabling Requirements 142
 - Specification 04 WAO Copper and Fiber Patch Panel and Patch Cord Requirements 145
 - Specification 05 Indoor/Outside Plant Fiber Optic Cable Requirements 152
 - Specification 06 OSP/Riser/Backbone Fiber Optic Patch Panel/Patch Cords 158
 - Specification 07 Equipment Racks and Distribution Cabinets 161
 - Specification 08 Electrical Protections, Bonding and Grounding 176
 - Specification 09 Outside Plant and Riser Cable Labeling Requirements 179
- APPENDIX B 189
 - Reference Materials 189
- Appendix C 194
 - Definitions 194
- APPENDIX D 205
 - UC Davis Policy and Procedure Manual 205

List of Tables

Table 2-1 Conduit Size Requirements.....	21
Table 2-2 Vertical and Horizontal Separations	21
Table 4-1 Maximum Allowable Conduit Fill.....	50
Table 4-2 Conduit Bend Radiuses.....	50
Table 4-3 Maximum Fill Requirements for Riser Cable	52
Table 4-4 Sizing a Pull Box	59
Table 6-1 Permanent Link Testing	81
Table 6-2 Maximum Loss Measurements.....	83
Table 6-3 Cross Connect Field Color Codes.....	84
Table 6-4 Recommended Size of Riser Fiber Optic Cable	86
Table 6-5 Maximum Fill Requirements for Riser Cable	87
Table 7-1 Recommended Size of OSP Fiber Optic Cable.....	96
Table 8-1 OES/ACS Circuit Merit Rating System	107
Table 8-2 Antenna Specifications.....	108
Table 8-3 RF Loss Characteristics	108
Table 8-4 In-building RF Coverage System Cost Estimating.....	109
Table 10-1 MATV WAO/Patch Panel Termination Hardware	115
Table 10-2 Coax Cable Specifications	121
Table 12-1 OSP Layer Convention Details.....	126
Table 12-2 OSP Cable Symbols and Descriptions	130
Table 12-3 ISP Floor plan Symbols and Descriptions	131
Table 12-4 ISP Floor Plans – NAM Reference Layers	132
Table 12-5 ISP Closet Bird’s Eye Details – Comm. Room Layering Convention.....	132
Table 01-1 WAO Faceplates and Surface Mount Boxes	135
Table 01-2 Wiremold® and Ortronics® Raceway Products	136
Table 01-3 Copper and Fiber NAM Modules	136
Table 02-1 VOICE NAM MATRIX.....	139

Table 02-2 DATA NAM MATRIX 140

Table 02-3 MATV NAM MATRIX..... 140

Table 02-4 FTTD NAM MATRIX..... 141

Table 03-1 Copper UTP Cable Specifications 143

Table 03-2 Horizontal Fiber Optic Cable Specifications 144

Table 04-1 Data Patch Panel Specifications 146

Table 04-2 Manufactured Data Patch Cords Lengths/Specifications 149

Table 04-3 Manufactured FTTD Patch Cords Lengths/Specifications 150

Table 05-2 Single-mode Cable Specifications 156

Table 05-3 Multimode Cable Specifications 157

Table 07-1 Distribution Equipment Rack/Cabinet Descriptions 161

Table 07-2 Equipment Rack and Cabinet Dimensions 164

List of Figures

Figure 2-1 Typical Maintenance Hole 24

Figure 2-2 Typical Hand Hole 25

Figure 4-1 Typical TS (IDF) Layout 45

Figure 4-2 Firestopping Requirements 45

Figure 4-3 Firestopping Label..... 46

Figure 4-3 Conduit Labeling 51

Figure 4-4 EMT Conduits Placed Above Hard or Limited Access Ceiling 55

Figure 4-5 Cable Tray Labeling 56

Figure 4-6 Pull Box configurations..... 58

Figure 4-7 Measuring a Pull Box 58

Figure 6-1 ADA Compliant Courtesy and Emergency Call Telephones 66

Figure 6-2 Voice 110-type Cross-Connect System 72

Figure 6-3 Riser Segment 85

Figure 6-4 UC Davis Test Documentation Sheet Cooper OSP/Riser Cable (Sample) 88

Figure 6-5 UC Davis Test Documentation Sheet Fiber Optic FTTD/OSP/Riser Cable (Sample) 90

Figure 7-1 Trench cross-section for paved areas 94

Figure 7-2 Trench cross-section for non-paved areas 94

Figure 7-3 Building Entrance Terminal Layout 101

Figure 12-1 OSP Drawing Copper Cable Callout 127

Figure 12-2 OSP Drawing Fiber Optic Cable Unique Numbering System 127

Figure 12-3 OSP Drawing CAAN Fiber Optic Cable Callout..... 128

Figure 12-4 OSP Drawing MH/HH Fiber Optic Cable Callout..... 128

Figure 12-5 OSP Drawing Terminal Callouts..... 129

Figure 12-6 OSP Drawing Maintenance/Hand Hole and Conduit Callouts 129

Figure 02-1 Labeling Flush Mounted WAO 138

Figure 02-2 Labeling Surface Mounted WAO..... 138

Figure 02-3 Labeling Flush Mounted FTTD WAO 139

Figure 04-1 Sample Labeling 24-port Patch Panel..... 150

Figure 04-2 Sample Labeling FTTD Patch Panel 151

Figure 05-1 Dielectric OSP Fiber Optic Cable 154

Figure 05-2 Armored OSP Fiber Optic Cable 154

Figure 07-1 Typical ADF Equipment 165

Figure 07-2 Typical ADF Cabinet 166

Figure 07-3 BDF/IDF Equipment Racks: 167

Figure 07-4 Type 1 IDF Equipment Racks: 168

Figure 07-5 Type 2 IDF Cabinet: 169

Figure 07-6 Type 3 IDF Cabinet: 171

Figure 07-7 Type 3 IDF Wall Mounted Cabinet: 172

Figure 07-8 Type 3A Wall-Mounted Layout..... 173

Figure 08-1 TMGB/TGB Busbar Labeling..... 178

Figure 08-2 Bonding and Grounding Layout..... 178

Figure 09-1 Fiber Optic Closet Connector Housing Labels 182

Figure 09-2 Vertical 568SC Duplex Fiber Optic Connector Panel Numbering Sequence 184

Figure 09-3 Horizontal 568SC Duplex Fiber Optic Connector Panel Numbering Sequence 184

Figure 09-4 Fiber Optic Cable Sheath Labels 184

Figure 09-5 Fiber Optic Cable Label Sequence 185

Figure 09-6 Fiber Optic Cable Label Sequence (MH/HH Splice)..... 185

Figure 09-7 Building Entrance Terminal Label Sequence 186

Figure 09-8 Copper Cable Sheath Labels 187

Figure 09-9 Copper Cable Label Sequence 188

Section 1.0 Introduction

1.1 About this Manual

1. This manual contains the Telecommunications Standards for use by the campus project managers, consultants and telecommunications design professionals who are involved in telecommunications projects on the UC Davis campus. This manual shall be used as a guide for projects providing telecommunications infrastructure and cabling, including inside and outside plant cable, wireless networks, in-building radio systems, broadband video, audio-visual and network systems. Work may include new and renovated buildings, as well as, the upgrading and/or the addition of cabling infrastructures and electronic equipment.

2. This manual assumes that the user is familiar with telecommunications distribution systems, the cable and hardware used in them, the cabling pathways and support structures and the installation of cabling, wireless radio, video, audio-visual and network systems in buildings and campus environments. It is not intended to be a training manual in the design of telecommunications distribution systems, a replacement of existing industry standards or used as an installation guide by an installing contractor.

3. Terminology used throughout this document to identify building termination locations is unique only to the UC Davis campus. Terms such as Area Distribution Frame (ADF), Building Distribution Frame (BDF), Intermediate Distribution Frame (IDF) Master Antenna Television (MATV) and Network Access Module (NAM) are used in lieu of industry standard terms, such as Main Cross-Connect (MC), Intermediate Cross-Connect (IC), Horizontal Cross-Connect (HC), Community Antenna Television (CATV) and Information Module (Jack). The requirements for these locations still adhere to the American National Standards Institute (ANSI), Telecommunications Industry Association (TIA) and Electronic Industries Alliance (EIA) standards.

4. Requests for variances or clarification of specific design and/or standards issues shall be submitted to CR on the Standards Variance Request Form. Forward the Standards Variance Request Form to the Project Engineer with UC Davis Engineering and Construction Management (ECM), Communications Resources Department. This form may be downloaded from the CR Projects, Telecommunications Standards web site (www.cr.ucdavis.edu).

5. Catalog numbers and specific brands, trade names or manufacturer's names followed by the designation "or equal" are used in conjunction with material and equipment required by the Specifications to establish the standard of quality, utility and appearance required. The contractor shall use the 1st manufacturer listed in the specification, unless the contractor requests a substitution of material. Substitution of material shall be submitted to the University Representative in accordance with Section 01630, Product Substitution Procedures, contained in the Campus Standards and Design Guide.

6. This manual also includes the following appendices:
 - a. **Appendix A** - Specifications contain detailed technical information.
 - b. **Appendix B** - References contain a list and brief description of the industry standards and guidelines for telecommunications systems and how to obtain a copy of them.
 - c. **Appendix C** - Glossary contains the definition of terms used in telecommunications design, engineering, construction and provisioning.
 - d. **Appendix D** - UC Davis Policy and Procedure Manual, Section 310-10.

1.2 Communications Resources (CR) Responsibilities

A. Communications Resources is responsible for UC Davis' inside and outside telecommunications system facilities, network connectivity and the associated backbone equipment. Communications Resources' responsibilities are outlined in the UC Davis Policy and Procedure Manual, Section 310-10 found in Appendix D of this document.

B. These responsibilities include the review of all new telecommunications project plans and require the following review items:

1. Communications Resources (CR) shall be provided copies of the Project Planning Guide (PPG), Capital Improvement Budget (CIB), Detailed Project Program (DPP), Design Guide or other such documents describing the University approved program¹. These documents shall be provided to Communications Resources upon approval of the governing agency responsible for managing that project.
2. Communications Resources shall be provided Schematic Design (SD) documents for review at each stage of the schematic design process, and provided a minimum of ten workdays from date documents are received by CR for review and return of comments.
3. Communications Resources shall be provided Design Development (DD) documents for review at each stage of the Design Development process, and provided a minimum of ten workdays from receipt for review and return of comments.
4. Communications Resources shall be provided Construction Documents (CD) for review at each stage of the Construction Document process, and provided a minimum of ten workdays from date documents are received by the CR office for review and return of comments.

¹ Reference: UC Davis Campus Standards & Design Guide Administrative Requirements, May 2003

1.3 Architects and Engineers (A&E) Role

A. A&E is the focal point for coordinating the various engineering consultants during the design process. To ensure each design includes all requirements necessary to support current and future telecommunications needs, the information provided in this document shall be included in the project specifications and drawings.

B. When a new building or building renovation is planned, drawings are typically released for review by A&E in the following order:

1. Schematic - These are the initial planning documents and design drawings which assist departments in the early stage of the project.
2. Design Development - As the A&E design process progresses, overlays are developed to show the various structures and systems planned for the building.
3. Construction Documents - These documents depict the final design before bid submittal is undertaken.
4. Working Copy - This is the Bid Copy.
5. Submittal - These documents depict the type and manufacturer of products the contractor plans to install during the project.
6. "Record Document" Drawings - These drawings and documents represent the project as it is finally constructed and are deliverable prior to final inspection of the project.

Note: CR's ECM office review comments shall be incorporated into the project documents prior to the next review phase or an explanation from the design professional shall be provided to the ECM office regarding the status of the referenced comments.

C. Architects, contractors, and telecommunications design professionals shall indicate, on the design drawings and in the design specifications, the location and specification of the physical infrastructure required for a complete telecommunications cabling pathway and distribution system. This physical infrastructure shall include:

1. Work Area Outlet (WAO) and Network Access Modules (NAM). Reference Specification 01, NAM Faceplates, Surface Mount Boxes, Wiremold® Adapters and Modules, for a complete description of a NAM.
2. Cabling termination hardware for a complete telecommunications (voice and data), in-building 800 MHz radio, video broadband, audio-visual, and wireless network systems.
3. The infrastructure necessary to support the horizontal, riser and campus backbone cable systems.

4. The ADF, BDF and IDF locations.
5. The infrastructure necessary to interconnect buildings, to include conduit, maintenance and hand holes, building entrances, entrance protectors, cables, splices and connection to Communications Resources service points.
6. Grounding and bonding requirements and locations.
7. Electrical service requirements and service points for ADF's, BDF's, and IDF's, as well as, any necessary ancillary electrical work as part of the project.
8. During the planning, design and construction phases of a project, the in-building 800 MHz radio systems shall be planned and accounted for. Reference Section 8.0, 800 MHz In-Building Radio Systems, in this manual.

D. CR shall be included early in the programming phase. CR can assist in surveying potential building sites for service connections to the existing campus infrastructure and assist in programming the required communication spaces.

1.4 Communication Consultant/Designer Role

A&E, at its option and for a fee, may contract with a communication consultant or request CR to complete a communications design. Regardless of the approach taken, A&E shall provide drawings to the consultant or CR so communication design documents can be created. A&E shall also incorporate comments concerning the project specifications and/or drawings into the various document packages.

1.5 The Telecommunications Standards Design Process

A. The UC Davis telecommunications standard is divided into 11 sections, and formatted to follow the Construction Specifications Institute™ (CSI) format:

1. Section 2.0, Site Construction refers to the cabling and infrastructure that interconnects buildings or systems on the campus.
2. Section 3.0, Architectural Requirements refers to the Equipment and Telecommunications Rooms that house the ADF, BDF and IDF. The ADF, BDF or IDF is the room that houses common network equipment, such as switches and UPS'.
3. Section 4.0, Electrical Requirements refers to the electrical requirements for the Equipment and Telecommunications Rooms(ER/TR), in addition to the support structure for building cabling system.
4. Section 5.0, Mechanical refers to the HVAC requirements of the Equipment and Telecommunications room.

5. Section 6.0, Communications Designer refers to the horizontal and riser segment of the structured cabling system, to include WAO's, the hardware for terminating the horizontal cable from the WAO, along with riser cabling to the IDF and testing requirements.
 6. Section 7.0, Outside Cable Plant, refers to the exterior cabling system that interconnects buildings or systems on the campus.
 7. Section 8.0, 800MHz In-Building Radio Systems, refers to the campus trunked radio system.
 8. Section 9.0, Wireless Network Systems, refers to the campus wireless Local Area Network (LAN) systems.
 9. Section 10.0, Master Antenna Television (MATV) System, refers to the campus cable television systems.
 10. Section 11.0, Audio-Visual Systems, refers to the campus building Sound, Video and Remote Control systems.
 11. Section 12.0, CADD Drawing Standards, refers to the standards for Inside and Outside plant diagrams and drawings.
- B. The design, engineering and installation of voice and data network electronic equipment is typically accomplished by Communications Resources.

Section 2.0 Site Construction

Site construction includes those support structures such as aboveground and underground conduit systems, maintenance holes (MH), hand holes (HH) and pole lines. Work performed in this segment shall be designed and installed per the California Electrical Code (CEC). Also reference the National Electrical Safety Code (NESC), California PUC General Orders 95 and 128 and the TIA-758-A Specifications for Outside Plant Construction.

2.1 Design Activities:

- A. Identifying conduit and cable routes from building to building.
- B. Selecting cable distribution methods.
- C. Determining maintenance hole and hand hole requirements.
- D. Determining any obstacles, existing conduit and cable facilities, or other underground utilities in the proposed construction area.
- E. Noting if right-of-way permits or easements are required.
- F. Determining if conditions exist that requires environmental impact applications.
- G. Determining electrical protection and bonding/grounding requirements.

2.2 Cable Distribution Methods

- A. Communications Resources' Engineering and Construction Management (ECM) office shall be contacted to determine the best cable distribution method along the proposed cable route. The method may be one, or a combination of, underground, direct-buried, directional boring, or aerial.
- B. An underground cable system consists of cables placed in buried conduits connected to maintenance holes (MH) and hand holes (HH). Conduits are also installed from the building entrance location to poles, pedestals, MH's and HH's. Splices shall be located in maintenance holes only, when required.
- C. A direct-buried cable system consists of cables and associated splices directly placed in the earth. The trench runs from the building entrance location to a pole, pedestal, MH or HH. This method is used **only** in cases where underground or aerial installations cannot be accomplished. Prior approval from the ECM office shall be obtained prior to the design of a direct-buried system.
- D. An aerial cable system consists of cables installed on aerial supporting structures such as poles, sides of buildings, and other above ground structures.

Note: An underground cable system shall be used if an existing or new conduit route is available between buildings.

2.3 Conduit Routes

The following steps shall be used to identify the conduit routes for new and renovated buildings:

- A. Obtain a copy of the most recent campus layout map.
- B. Determine where the conduit entrance point is for each building.
- C. Determine location, availability and size of the closest existing underground conduit system access point (MH/HH).
- D. Conduit routes shall not cross open land areas where future building may occur.
- E. All branch conduits exiting a MH/HH shall be designed as Subsidiary conduits only (exit from the end wall of the MH/HH, and not from the side wall).
- F. There **shall not** be more than the equivalent of two (2) 90-degree bends (180-degrees total) between pull points, including offsets and kicks. Back-to-back 90-degree bends shall be avoided.
- G. Where bends are required, manufactured bends shall be used whenever possible. Bends made manually shall not reduce the internal diameter of the conduit.

2.4 Underground Conduit Construction

2.4.1 General

- A. Conduit shall be Polyvinyl-Chloride (PVC) Schedule 40 or 80 (dependent upon concrete encasement requirements), corrosion-resistant plastic with a 4-inch inside diameter for underground installations, and Galvanized Rigid Steel (GRS) or PVC Externally Coated GRS for riser applications.
- B. Fabric, multi-cell type of innerduct shall be considered for conduits planned for fiber optic cable installations.
- C. Multi-cell or multi-bore type of conduit and industry standard Polyethylene (PE) or Polyvinyl Chloride (PVC) type of plastic innerduct shall **not** be designed without prior written approval by CR.
- D. The minimum depth of a trench shall allow 24-inches of cover from the top of the conduit/cable to final grade.
- E. All installed conduits shall be cleaned and verified with a flexible mandrel and a stiff brush. Mandrels shall be 12-inches in length, and sized to within 1/4-inch of the inside diameter of the conduit.

F. All conduits shall be provided with a ¼-inch polypropylene pull rope or tape with a minimum of 200 pound pulling tension, in addition to, a solid core #12 AWG copper wire in any unused conduit structures not programmed for immediate cable installations, or where all-dielectric fiber optic cable is installed singularly, for the purpose of locating and tracing the cable route.

G. All unused entrance conduits shall be installed with pull rope or tape and capped/plugged with expandable type duct plugs.

H. Conduit stubs entering the building shall extend beyond the foundation and landscaping. All conduit ends adjacent to the building shall be flagged for easy identification.

I. Conduit entering from a below grade point shall extend 4-inches above the finished floor in the ER/TR. Conduit entering from ceiling height shall terminate 4 inches below the finished ceiling.

J. Conduit shall be securely fastened to the building to withstand a typical placing operation performed by the service provider. The area around the conduit entrance shall be free of any construction, storage, or mechanical apparatus.

K. All metallic conduit and sleeves shall be reamed, bushed, and capped when placed.

L. Metal sleeves through foundation walls shall extend to undisturbed earth to prevent shearing.

M. The top of the conduit shall be buried at least 24-inches below the ground surface. Warning tape equipped with a metallic tracer shall be placed 18-inches above the conduit structure.

N. Underground conduit shall be terminated at the designated property line with a minimum cover of 24-inches.

O. Conduit **shall** be encased in concrete or cement slurry when the following conditions exist:

1. Minimum conduit depth cannot be attained.
2. Conduits pass under roadways, driveways, railroad tracks, or bend points subject to movement.
3. All conduit bends and sweeps shall be concrete encased to prevent movement and “burn-through” by the pull rope during cable installations.
4. Concrete encasement shall comply with State of California, Department of Transportation standard specifications.

5. An orange colored additive shall be raked or trowel-worked into the wet concrete or cement slurry to identify the duct structure as communications.

6. Reinforcing bars within the concrete shall be used at any location subject to extreme stress.

7. CR shall inspect and approve all conduits prior to encasement.

P. The end of the conduit that penetrates through the building's exterior wall shall be sealed with expandable type duct plugs (i.e. Jackmoon) inside the building to prevent rodents, water or gases from entering the building.

Q. There shall be no more than two 90-degree bends between pulling points on all conduits. This includes the turn from horizontal to vertical when entering the building from below. All bends shall be long, sweeping bends with a radius not less than 6 times the internal diameter of conduits 2-inches or smaller, or 10 times the internal diameter of conduits larger than 2-inches.

R. Conduit shall be positioned on the field side of the poles (the side that is protected from the normal flow of traffic). On joint use electrical poles, the telecommunications conduit shall be located 180-degrees from any electrical conduit, when possible, but no less than 90-degrees.

S. Warning tape containing metallic tracings shall be placed a minimum of 18-inches above the underground conduit/duct structure and direct-buried cable to minimize any chance of an accidental dig-up. The American Public Works Association has adopted the color orange for the telecommunications cables. Both ends of the metallic warning tape shall be accessible from both ends after installation. Communications Resources shall approve this accessibility prior to completion of conduit/duct and cable placement.

T. A university representative will observe and inspect utilities trenching, excavation, backfilling and compaction as appropriate. Contractor shall appropriately schedule all inspections prior to commencing trenching and backfilling operations. All installations are subject to satisfactory inspection by the University's representative.

U. Contractor shall request to locate and mark all subsurface utilities, such as power, communications, gas, water, outdoor lighting, etc. shall be requested 48 hours (or in accordance with statutes regulating utilities) prior to any excavation on campus. An Underground Service Alert (USA) call number receipt (ticket) shall be present and on-site and all utilities located and marked before any construction work involving excavation begins.

2.4.2 Sizing Underground Conduit

The quantity and size of underground entrance conduits are based on the anticipated number and type of telecommunications circuits that shall be brought into the building. UC Davis requires two entrance pairs per 100 square feet of usable office space. The following table shows the data for the quantity and size of underground entrance conduits. Reference Table 2-1.

Table 2-1 Conduit Size Requirements

Copper Entrance Pairs	Conduits Required
1 - 1000	1 each 4-inch conduit + 2 spare 4-inch conduits
1001 - 2000	2 each 4-inch conduits + 2 spare 4-inch conduits
2001 - 3000	3 each 4-inch conduits + 2 spare 4-inch conduits
3001 - 5000	4 each 4-inch conduit + 2 spare 4-inch conduits
5001 - 7000	5 each 4-inch conduits + 2 spare 4-inch conduits
7001 - 9000	6 each 4-inch conduits + 2 spare 4-inch conduits

2.4.3 Conduit Separation Requirements

A. The minimum recommended separations between telecommunications conduit systems and outside surfaces of foreign structures are shown in Table 2-2. These clearances are required by the *NESC* for personnel safety and the protection of telecommunications equipment.

Table 2-2 Vertical and Horizontal Separations

Adjacent Structure	Minimum Separation
Power or other foreign conduit	3-inches of concrete, or 4-inches of masonry, or 12-inches of well-tamped earth
Pipes (gas, oil, water, etc.)	6-inches when crossing perpendicular 12-inches when parallel
*Railroad crossings (except street railways)	50-inches below top of rail 12-feet from the nearest rail if terminating on a pole 7-feet from the nearest rail if terminating on a pole at a siding
Street railway	3-feet below the top of the rail
UCD Campus Steam Lines	10-feet parallel and perpendicular (UCD campus requirement)

*Additional local requirements may apply.

B. Per the A&E Campus Standards and Design Guide, all plastic underground piping shall be kept at a 10-foot distance from steam/condensate lines unless approved by the University's Representative. When crossing is necessary within the 10-foot distance limitation, transition to an A&E approved metallic pipe for at least 10 feet on either side of the intersection. Communications conduits may also require a pipe insulation treatment be installed. Install pipe insulation per A&E campus standards.

C. If required separation **cannot** be obtained, an engineered solution shall be submitted to the A&E project manager and CR for review prior to the beginning of any installation work.

2.5 Maintenance Holes (MH) and Hand Holes (HH)

2.5.1 General

A. MH/HH's are required where maximum cable reel lengths are exceeded, at the intersection of main and branch conduit runs, and at other locations where access to the cable in a conduit system is required.

B. The maximum distance allowed between buildings and MH/HH's or between two MH/HHs' is 600 feet.

C. CR has accepted the general sizing guidelines for MH/HH's as used by the Regional Bell Operating Company (RBOC) (Southwestern Bell Communications, SBC). These guidelines or specifications are referred to as PTS, and are based on ultimate requirements.

D. MH/HH's shall meet the weight-bearing standards required under CPUC's General Order Number 128.

E. MH's placed in vehicular traffic areas shall be constructed to withstand a minimum of ASSHTO-H20-44 full traffic loading as designated by the American Association of State Highway Officials, and the UC Davis Campus Standards and Design Guide. Floors of manholes shall meet the requirements of Public Utilities Code, Section 8054.

F. Standard precast MH/HH's shall be used. Site-cast MH/HH's may be used only when the size required exceeds precast standards, obstructions prohibit placing precast MH/HH's or a custom design is required.

G. MH's shall be sized to meet the maximum conduit requirements and shall be located to optimize the use of the associated conduit routes.

H. The strength of concrete used for MH/HH's shall be at least 3,500 psi.

I. All hardware in MH/HH's shall be galvanized. All MH/HH's shall be equipped with:

1. Bonding and grounding attachments.
2. Pulling eyes shall be a minimum of 7/8-inches in diameter and located at opposite ends of each conduit entrance point.
3. A sump of at least 12-inches in diameter.
4. An entry ladder (MH only).
5. A minimum 30-inch diameter round cover (MH only).
6. All MH/HH covers shall be marked for easy identification (Communications), and have a permanently attached label indicating the assigned MH/HH number.
7. Uni-struts or 1/2-inch inserts for the installation of racking and cable steps.

J. MH's that are between 12-feet and 20-feet long shall use two covers. MH's over 20 feet long shall use three covers.

K. MH locations where the distance between the ceiling of the manhole and the street level exceeds 24-inches shall require the installation of permanent steps in the neck of the MH. These steps shall be installed in the neck rings at the same time as the MH is being installed, per manufacturer instructions. Steps **shall not** be cut and cemented in place after the installation of the neck ring.

L. Where placement location is a roadway, driveway, bike path, fire line, loading dock or trash pickup area, a MH shall be provided only.

M. See Figure 2-1 for an example of a typical MH, and Figure 2-2 for a typical HH.

2.5.2 Additional HH Requirements

A. All Hand Holes (HH) shall be equipped with slip resistant covers with height adjustment brackets, torsion assist openings, guard bars and hex head type bolts.

B. All covers shall be rated for heavy and/or constant vehicular traffic, regardless of placement location.

C. HH's shall not be sized over 4-feet by 4-feet by 4-feet, nor contain more than 4-each trade size 4 conduits entering or exiting the ends of the HH. The typical size of a HH used on the UC Davis campus is the RBOC standard 3-feet by 5-feet by 3-feet.

D. HH's **shall not** be placed in a main conduit route between two MH's.

E. Splices **may** be permitted in HH's dependent upon cable type and size. Communications Resources shall approve all HH splice locations prior to their installation.

F. HH's shall be placed at strategic locations in a conduit system to allow installers to pull cable through the conduit with minimum difficulty and to protect the cable from excessive tension.

G. HH's shall contain a concrete floor.

Figure 2-1 Typical Maintenance Hole

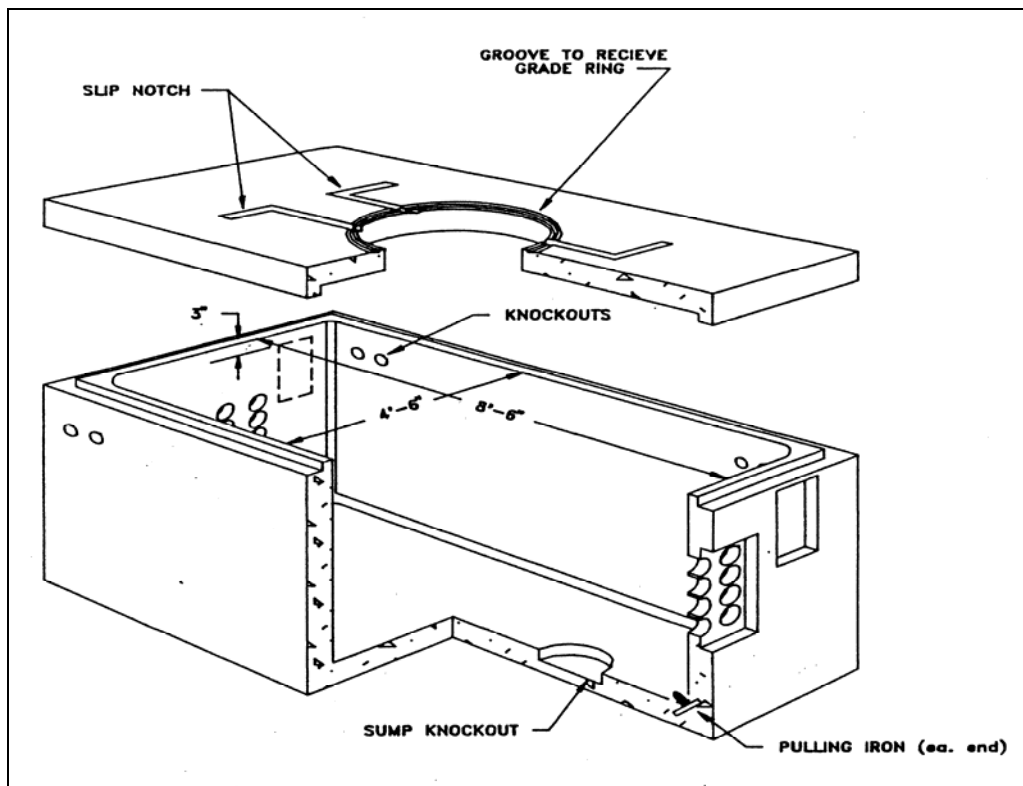
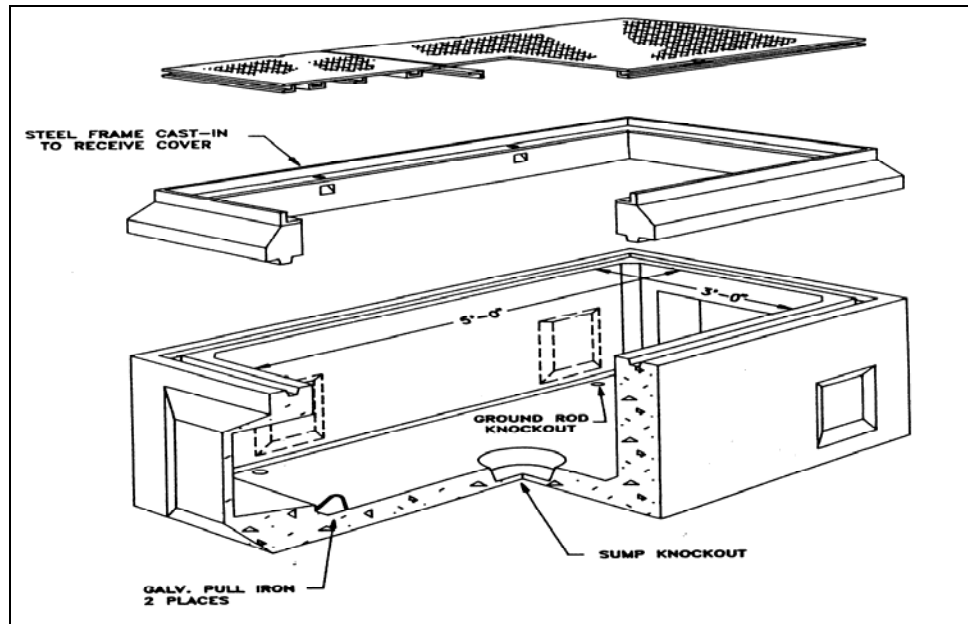

Figure 2-2 Typical Hand Hole



2.5.3 MH/HH Conduit Entry Requirements:

- A. Trade size-4 conduit knockouts shall be located at opposite ends of the MH/HH, and at a point approximately halfway between the floor and roof.
- B. For wall racking considerations, design splayed duct bank entrances at the end walls rather than center placement to ease in the racking of the cables and splices.
- C. Conduit servicing buildings or other MH/HH's shall be installed using the subsidiary conduit method.
- D. Lateral conduits entering/exiting MH/HH's are **not** allowed.
- E. If the total number of conduits being placed is significantly less than the capacity of the termination MH or cable entrance, conduit should enter at the lower level. The upper space shall be reserved for future additions.
- F. Conduits installed between MH/HH's and buildings, and between other MH/HH's shall be sloped per TIA 758-A to ensure proper drainage of water.
- G. All conduits entering buildings shall be plugged with expandable type duct plugs. MH/HH conduits shall be plugged with duct seal material to prevent the entrance of water and gases.

H. Core drilled holes into existing MH/HH's shall only be accomplished via shop drawings that clearly identifies the methods and procedures to be used in the coring process. Shop drawings shall to be submitted to Communications Resources for review and comment prior to commencement of work.

I. No more than two 90-degree sweeps or bends shall be allowed between buildings and MH/HH's and between MH/HH to MH/HH's. 45-degree conduit angles are preferred. Regardless of depth, **all** bends and sweeps shall be concrete encased to prevent movement and "burning through" by the pull rope during cable installations.

2.6 Aerial Cable Requirements

A. Overhead line construction (aerial electric supply and communications systems) specifications are regulated by the California Public Utilities Commission (CPUC), and shall conform to General Order (G.O.) Number 95.

B. Aerial cable projects shall be designed from engineering drawings approved by Communications Resources. These drawings² shall include the following information:

1. Pole data, including pole class, length, heights of attachments, cross arms and pole steps.
2. Cable support strand sizes, down guys, anchors and lead-height ratios.
3. Span lengths, including appropriate information for slack span constructions, crossovers, pull-offs, or any other special proposals.
4. Grounding and bonding instructions.
5. Construction notes that are applicable to the work being performed.
6. A legend explaining symbols of all relevant structures.
7. Cable counts, types and directions of feed.
8. Terminal counts and splicing details.

C. Aerial entrances shall be limited to small buildings requiring 100 cable pairs or less for service connections.

² Reference: UC Davis Campus Standards & Design Guide, Administration Requirements, May 2003.

D. The following steps shall be taken to design an aerial plant:

1. Select permanent locations for pole lines while considering:
 - a. Future road widening and expansion, existing utilities and road, railway, and power line crossings.
 - b. Safety and convenience of workers and the public.
2. Obtain necessary permits and easements for placing and maintaining pole lines.
3. Coordinate with other utilities with respect to possible joint use and to minimize inductive interference.
4. Design the pole line for ultimate needs, taking into consideration pole line classification, storm loading, and clearance requirements.
5. Poles shall be of proper strength, class and length to meet the weights of cables, wires, and strands. See Table 6 in CPUC's G.O. 95 for the proper setting depths for various pole lengths.
6. The most economical span length shall be used:
 - a. The span from the last pole to the building shall not exceed 100 feet.
 - b. Slack span construction shall be used.
 - c. Self-supporting cable shall be considered prior to the design of typical suspension strand and cable.
 - d. Aerial cables shall be placed on the roadside of the pole line.
7. For minimum clearances of drop wires and cables over streets, sidewalks, agricultural areas, railroads, etc., reference the CEC. For additional information, also reference the CPUC's G.O. 95, Rule 37 and Table 1, the NESC and TIA 758-A.
8. Aerial cables shall enter a building through a conduit with an approved weatherproof service head.
9. Aerial cables shall be labeled upon entering and prior to exiting a building and MH/HH's in accordance with Specification 09, Outside Plant and Riser Cable Labeling Requirements.

2.7 Project Drawings

Project drawings shall include the following site construction information:

- A. Details of typical trench cross sections showing conduit locations in the trench, clearances from final grade, backfill materials and depths, pavement cutting information, and compacting requirements for both paved and unpaved areas.
- B. Construction notes applicable to the work being performed.
- C. A scale drawing showing location ties to existing structures, cable, conduit, MH/HH's, and any conflicting substructures. Profile drawings of congested areas where vertical and horizontal separation from other utilities is critical during cutting and placing operations.
- D. A legend explaining industry standard drawing symbols of all relevant structures and work operations.
- E. Conduit types, dimensions, and wall-to-wall measurements when used with MH/HH, pedestals and Equipment and Telecommunications Rooms (ER/TR's).

Section 3.0 Architectural Requirements

3.1 General

During a building design phase, there are a number of communication infrastructure requirements that must be addressed by the architect. The following information is provided to address those architectural requirements and how they shall be incorporated in the final design.

3.1.1 Telecommunications Spaces (TS)

A. Telecommunications Spaces are special-purpose spaces that provide a secure operating environment for telecommunications and/or network equipment. Each type of space has a specific function and requires its own individual space within a facility. Depending on the building size, design and network requirements, one or more of these functions may be combined into one space.

B. The industry term “Telecommunications Spaces”, when used, shall refer to Equipment and Telecommunications Rooms, as well as, ADF, BDF and IDF in this Telecommunications Standards document.

3.1.2 Equipment Room (ER)

A. The Equipment Room (ER) is the room within a building that houses the Area Distribution Frame (ADF) and Building Distribution Frame (BDF) for telecommunications equipment that meets the voice, data, video, radio and wireless needs of an entire building, and/or a designated area on the UC Davis campus. In some cases, an ER may also contain the Entrance Facility (EF) and Intermediate Distribution Frame (IDF).

B. An ER provides a controlled environment to house telecommunications equipment, termination hardware, splice closures, Main Telecommunications Grounding Busbar (MTGB) grounding and bonding facilities and protection apparatus where applicable. Digital Loop Carrier equipment, local area network switches, video distribution equipment, wireless network equipment, 800MHz in-building radio equipment and large uninterruptible power sources are types of telecommunications equipment found in an ER.

C. ER's are considered distinct from Telecommunications Rooms (TR) due to the nature and/or complexity of the equipment they contain.

D. ER's shall be designed and provisioned according to the requirements in ANSI/TIA/EIA-569-B.

E. The term ER, when used, refers to TR's, ADF, BDF and/or IDF's on the UC Davis campus.

3.1.3 Telecommunications Room (TR)

A. Telecommunications rooms (TRs) differ from equipment rooms (ERs) and entrance facilities (EFs) in that they are generally considered to be floor serving as opposed to building or campus serving. Every building is served by at least one TR or ER, with a minimum of one TR per floor.

B. The TR is the room within a building that houses the Intermediate Distribution Frame (IDF) on the UC Davis campus for the primary function of providing a connection point between backbone and horizontal infrastructures. ANSI/TIA/EIA-568-B.1 has replaced the term Telecommunications Closet with the term Telecommunications Room.

C. BDF may also be called a TR. The BDF is a building serving space providing a connection point between campus backbone cables and the building infrastructure system. The BDF may be floor serving when collocated with an IDF.

D. Horizontal and backbone cable terminations shall be accomplished using manufactured patch panels and patch cords for data and jumper wire for voice circuits. On the UC Davis campus, the term IDF shall be used for termination points servicing WAO locations.

E. TR's shall be designed and provisioned according to the requirements in ANSI/TIA/EIA-569-B.

E. The term TR's, when used, refers to TS's, BDF's and/or IDF's on the UC Davis campus.

3.2 Room Location

There are a number of factors that need to be considered when placing Telecommunications Spaces (TS) within new or remodeled facilities. Site selection factors for the various rooms are addressed below. Of these factors, the two most important are "stacking" of the spaces and providing a method that would allow the spaces to be expanded, if required, in the future.

3.2.1 Telecommunications Spaces shall:

A. Avoid locations that limit expansion such as structural steel, stairwells, and elevator shafts, outside walls or other fixed building walls.

B. Have easy access to distribution cable pathways.

C. Be easily accessible for the delivery of large equipment to the room.

D. Minimize the size and length of the backbone and horizontal distribution cables.

- E. Be accessible directly from public hallways and not through offices or other utility spaces.
- F. Dedicated to the telecommunications function and related support facilities.
- G. A single function room and shall not be shared with electrical installations or other equipment or building services other than those required in direct support for telecommunications equipment or services. Reference UCD Policy & Procedure Manual, Section 310-10, Telecommunications Services dated 1/15/02.
- H. Located as close as practical to the center of the area served and preferably in the core area. However, the location shall be such that the room can be expanded in the future.
- I. Located in a dry area not subject to flooding and as close as practical to the vertical backbone pathway.
- J. Located where building entrance cables shall not be exposed for a cable length distance of more than 50' per the 2001 California Electrical Code, Articles 770-50 and 800-50.2.
- K. If the Telecommunications Entrance Facility (TEF) is not co-located with a Telecommunications Space, the TEF shall be vertically aligned with the TS in a multistory building.
- L. Vertically aligned (Stacked) in multistory buildings. That is, constructed so each IDF is placed above the BDF/IDF (TS) on the floor below.
- M. Horizontal pathways shall terminate in the TS located on the same floor as the area being served.
- N. Specifications for related facilities shall accommodate the applicable seismic zone 4 requirements.
- O. Located such that the average horizontal cable run is 150 feet or less and that no individual cable run exceeds 295 feet.

3.2.2. Telecommunications Spaces shall not:

- A. Contain other building systems, such as, but not limited to, audio-visual (A/V) equipment, access control systems, fire alarm panels, building management systems or computer servers. No other building systems shall be housed within this room without the prior written approval of Communications Resources. Reference UCD Policy and Procedures Manual Section 310-10, Telecommunications Services, dated January 15th, 2002.
- B. Be located near electrical power supply transformers, elevator or pump motors, generators, x-ray equipment, radio transmitters, induction heating

devices and other potential sources of electromagnetic interference (EMI) and radio frequency interference (RFI).

C. Be located near sources of mechanical vibration that could be conveyed to the room via the building structure.

D. Equipment not related to the support of the telecommunications function (e.g. sprinkler, steam, chilled water, supply and waste piping, ductwork, pneumatic tubing, etc) shall not be installed in, pass through, pass overhead or enter the telecommunications space.

E. Be located below water level unless preventive measures against water infiltration are employed. A floor drain and/or sump pump shall be provided within the room if risk of water ingress exists.

F. Contain water or drain pipes (**to include overhead piping of any type**) not directly required in support of the equipment within the room. Drain (drip) pans with an appropriate drain shall be placed beneath each pipe, if required. Pipes for sprinkler heads located within the room **shall not** be located directly above electronic equipment racks and/or cabinets.

G. Be located in any place that may be subject to water or steam infiltration, humidity from nearby water or steam, heat, and any other corrosive atmospheric or environmental conditions.

H. Share space in electrical closets, boiler rooms, washrooms, janitorial closets, and storage rooms.

I. In addition, acoustic noise levels in the Telecommunications Spaces must be maintained at a minimum level by locating noise-generating equipment outside the TS.

3.3 Room Sizing

A. The size of the TS depends upon the size and variety of the equipment to be installed and the size of the area that the room will serve.

B. The TS shall provide enough space for all planned termination and electronic equipment and cables, including any environmental control equipment, power distribution/conditioners, and uninterrupted power supply systems that will be installed to serve the telecommunications equipment.

C. The TS shall also provide space for access to the equipment for maintenance and administration and for equipment changes with minimal disruptions.

D. The minimum ER/TR is based on providing telecommunications service to one individual work area of 100 sq. ft.

E. The sizes of all telecommunications spaces (ADF/BDF/IDF) listed are **minimum requirements**. Depending on the requirements and services performed by the building occupants, additional space may be required.

F. For early planning purposes, assume a minimum of three open equipment racks or enclosed cabinets will be required in any size building.

G. Larger size buildings may require additional rows of equipment racks or cabinets. Contact CR for instruction on how large the ER/TR's need to be.

H. There shall be a minimum of one TS per floor. One additional TS for each area up to 10,000 sq. ft. shall be provided when the floor area to be served exceeds 10,000 sq. ft or the horizontal distribution distance to the workstation exceeds 295'.

I. Based on one workstation per 100 square feet (sq. ft.), the TS shall be sized as follows:

1. If the serving area is 5,000 sq. ft. or less, the TS shall be 10-feet wide by 8-feet long.
2. If the serving area is between 5,000 and 8,000 sq. ft., the TS shall be 10-feet wide by 9-feet long.
3. If the serving area is between 8,000 and 10,000 sq. ft., the TS shall be 10-feet wide by 11-feet long.
4. If the floor area is over 10,000 sq. ft., then the TS size **shall be** increased, based upon 0.75 sq. ft. for every additional 100 sq. ft. of usable space the TS will support.

3.4 Room Lighting

It is important that proper work lighting be provide in all Telecommunications Spaces.

3.4.1. Lighting shall:

- A. Provide a minimum equivalent of 50 foot-candles when measured three feet above the finished floor and in the middle of all aisles between racks or cabinets.
- B. Be mounted a minimum of 8-feet, 6-inches above the finished floor. Position the room light fixtures above aisle area and between equipment racks and cabinets only.
- C. Have light switches located near the entrance door of the TS. Dimmer switches are not permitted.
- D. Recommend at least one light fixture be on an emergency power circuit, if available in the building.

3.4.2. Lighting shall not:

- A. Be placed directly over equipment racks, cabinets, cable trays or runways as to cast a shadow over the work area.
- B. Receive power from the same electrical distribution panel breaker as the telecommunications equipment in the TS.

3.5 Water Infiltration

- A. As stated earlier, Telecommunications Spaces **shall not** be located below water level unless preventive measures against water infiltration are employed. The TS shall be free of water or drain pipes not directly required in support of the equipment within the TS.
- B. A floor drain, automatic pump and warning alarm shall be provided within the TS if the risk of water ingress exists.

3.6 Fire Safety and Protection

- A. Portable fire extinguishers shall be provided and maintained within 75-feet or less travel distance from any part of the occupied space within the TS per campus requirements. The size of the fire extinguisher shall be a minimum 2-A, 10-B, C rating.
- B. If overhead sprinklers are required within the equipment area, the sprinkler heads shall be provided with protective wire cages to prevent accidental operation.
- C. Drainage troughs shall be placed under the sprinkler pipes to prevent leakage onto the electronic equipment within the room. Drain troughs shall be provided with a drain that will route the water outside of the TS. Alternate fire-suppression systems should be considered in these areas.
- D. Additional equipment such as fire alarm panels, building monitoring devices, building access systems, A/V systems and file servers shall **not** be located in the TS. Space for these services shall be provided as part of the electrical room or in a separate location.
- E. If an access raised-floor system is to be installed in any TS and a fire detection system is required under the floor, the system shall be a cross-zone detection system. In addition, placement of the detector may affect the way cables are routed under a raised floor. If ionization detectors are installed, there is a potential problem with the accumulation of dust under the floor. It is possible during the performance of cable work under the floor that dust could set off the detectors. Provisions shall be made in the fire detection system design to reduce the possibility of false alarms and activation of a fire suppression system, such as, but not limited to, temporarily disarming the system.

F. Emergency lighting and signs shall be properly placed such that an absence of light will not hamper emergency exit.

3.7 Doors

A. The door shall be a minimum of 3-feet wide and 6-feet, 7-inches high, without a doorsill.

B. Door shall be fire rated to match the fire rating of the wall in which it is installed, if applicable, or as required by local code requirements.

C. Doors shall not contain a glass viewing window or panel for added security.

D. If it is anticipated that large equipment will be delivered to the TS, a double door 6-feet wide by 7-feet, 5-inches high without a doorsill and center post is recommended. The door shall have a gasket to prevent dust from entering the room.

E. TS doors that open to an outside environment shall be rated for exterior use and shall have a weatherproof gasket to prevent vermin, water, dirt and dust from entering the room. A positive pressure type of HVAC system shall be installed in this type of TS.

F. Doors shall open outward (code permitting).

G. The keying of doors for all TS and Controlled Environmental Facilities (CEF) shall be keyed alike. Contact CR for proper key number.

H. Signage, when required, shall be consistent with UC Davis and/or building requirements. Signs shall indicate "Communications Room".

3.8 Interior Finishes

3.8.1 Floor

A. Floors shall be sealed concrete or tile to minimize dust and static electricity. Removable computer floor tiles shall be of a tile type surface.

B. Floor loading capacity in the ER (ADF/BDF) shall be designed for a minimum distributed load rating of 100 lbf/ft² and a minimum concentrated load rating of at least 2000 lbf. The floor loading for a TR (IDF) shall be designed for a minimum load rating of 50 lbf/ft². It shall be verified that concentrations of proposed equipment do not exceed the floor limit.

C. If a raised floor system is used, then it is possible the space will have to comply with the requirements of Article 645 Information Technology Equipment of the 2001 California Electrical Code and NFPA 75 Standard for the Protection Information Technology Equipment, 2003 Edition.

D. Finishes shall be light in color to enhance room lighting.

3.8.2 Walls

A. Interior finishes shall be in a light color to enhance room lighting.

B. All walls shall be lined with Trade Size void free, ¾-inch AC-grade plywood, 8 feet high.

C. The plywood shall be securely fastened to the wall-framing members. Wall anchors shall be flush to the plywood surface as to not obstruct the mounting of cabling hardware. The walls shall be capable of supporting attached equipment.

D. Plywood sheets shall be either:

1. Fire Rated by the manufacturer and painted with two coats of white paint. At least one (1) Manufacturer's Fire-Rated stamp shall be visible per sheet or partial sheet of plywood when painting is completed.

2. AC-grade painted with two coats of white Fire-Retardant paint. A CR representative shall be present at the time of painting to confirm and verify the use of Fire-Retardant paint.

E. Plywood shall be mounted vertically starting at 6-inches above the finished floor to a height of 8-feet, 6-inches.

3.8.3 Ceilings

A. Drop or false ceiling tiles **shall not** be installed.

B. Hard ceilings shall have EMT type conduit or sleeves installed to facilitate the installation and fire stopping of cables.

C. Open structure ceilings **shall** provide the same environmental conditions as a closed type of ceiling structure.

3.8.4 Clearance

A. The minimum clearance height in the room shall be 8-feet 6-inches without obstructions.

B. Provide the following clearances for equipment and cross-connect fields in the Telecommunications Spaces:

1. Allow a minimum of 36-inches of clear working space in front and rear of equipment cabinets, racks and cross-connect fields.

2. Allow for 6-inch depth off wall for wall-mounted equipment.

3. Provide a minimum 36-inch aisle between each row of racks.
4. A minimum aisle clearance of 30-inches is required at one end of each row of racks for an exit access.

Note: In many cases, equipment and termination hardware may extend beyond racks and backboards. It is important to note that the clearance is measured from the outermost surface of these devices, rather than from the mounting surface of the rack or backboard.

3.9 Telecommunications Spaces Construction Sequence

- A. Prior to the installation of cables, telecommunications and/or network equipment, all TS's shall be completed.
- B. In all cases, this means the TS shall have construction priority and may have to be constructed out of the normal building sequence.
- C. At a minimum, the following items shall be completed:
 1. All wall and rack-mounted electrical receptacles installed and operational.
 2. Interior finishes completed.
 3. Lighting and air conditioning systems installed and operational.
 4. Lockable doors installed and keyed to the CR standard.

3.10. Special Design Considerations

3.10.1 Slab on Grade

If a slab on grade approach is planned for the first floor of newly constructed buildings, then special attention shall be provided to potential communication WAO's that may be installed in the floor. The following minimum requirements:

- A. Supporting conduits shall run beneath the slab and shall be PVC schedule 40 or better.
- B. At no time shall the conduit run below the membrane barrier or be placed directly in the soil.
- C. Conduits shall **not** contain more than two 90-degree bends and exceed more than 100-feet in length between pulling points.

3.10.2 Work Area Outlets (WAO)

A. WAO density

1. A minimum of one WAO location containing one Voice and Data NAM shall be installed per work area. For planning purposes, space allocated per work area averages 100-square feet.

2. For building areas where it is difficult to add additional WAO's at a later date (i.e. private office space), a minimum of two separate WAO locations shall be provided in the initial design for that area, and they shall be located to offer maximum flexibility for change within the work area, (i.e. on opposing walls in private office space).

B. A minimum of one WAO shall be installed with a minimum of two Voice NAM's at the Fire Alarm Control Panel (FACP) located in the electrical or mechanical room.

C. A minimum of one WAO shall be installed with a minimum of one Voice NAM for each elevator phone at the Elevator Control Panel.

D. A minimum of one WAO shall be installed with a minimum of one Voice or Data NAM at the Building Environmental Control Panel.

E. A minimum of one WAO shall be planned for any Building Access Systems (card and palm readers) that may be installed in the building.

F. A minimum of one WAO shall be planned with a minimum of one Voice NAM for each wheel chair elevator phone.

G. WAO locations shall be coordinated with the furniture layout. A power receptacle should be installed near each WAO location (i.e. within 3-feet). WAO locations are typically at the same height as the power receptacles.

H. Open office area interior design, telecommunications distribution planning, and power system distribution planning should be coordinated to avoid conflicting assignments for pathways or WAO locations, installation sequencing problems, and other difficulties.

3.10.3 Building interfaces

Furniture pathways are entered from building walls, columns, ceilings, or floors. The interface between the building and furniture requires careful planning and may require special products or furniture options. Safety, reliability, and aesthetic concerns all favor concealment of the building and furniture pathway interface. These pathway interfaces shall not trap access covers or otherwise block access to WAO's, building junction boxes or pathways. Pathways used to interconnect the furniture with building horizontal pathways shall be provided with a cross-sectional area at least equal to the horizontal pathways cross-sectional area for the floor area being served.

3.10.4 Walls and columns

Raceways shall be provided between furniture pathways and the inside of building walls or columns.

3.10.5 Floors

A raceway shall be provided between furniture pathways and horizontal floor pathway terminations (end of conduit, flush junction boxes, recessed junction boxes, etc.). Alignment of furniture with building modules, duct locations and other cable delivery means should be considered as part of the layout planning. Furniture shall not be arranged such that pathway interfaces are in aisle spaces, where people walk or place their feet, or other places where such obstructions could create a hazard. Telecommunications consultant shall coordinate the furniture layout with the department.

3.10.6 Courtesy, Pay, Text, Emergency and Wheel Chair Elevator Telephones

In order to comply with the American Disabilities Act (ADA) Accessibility Guidelines:

- A. The mounting height of the device box for Wall Mounted Telephones shall be 40-inches Above the Finished Floor (AFF). Wall-mounted telephones shall not be installed above a counter top.
- B. The mounting height of the device box for a wheelchair accessible telephone (to include payphones and wheel chair elevator phones) shall be 40-inches AFF.
- C. If a Text Telephone is required, it shall not be mounted to the wheelchair accessible telephone position. The text telephone unit shall require a power receptacle at 18" AFF under the Text Telephone.
- D. If a wheelchair elevator is planned, a WAO shall be installed as close as possible to its location for the installation of an emergency phone.

3.10.7 Roof

- A. A&E shall contact CR to determine if there are any special requirements that could affect the roof design or structure. There is the possibility that an 800MHz's in-building radio antenna system may have to be installed on the roof.
- B. If an antenna system is to be installed:
 - 1. Additional space may be required to house the radio system equipment in the TS.
 - 2. Conduits from the TS to the roof shall be required.
 - 3. Additional AC power may also be required.

3.11 Campus Environments

Construction involving a new or existing building structure shall have an assessment of the outside conduit infrastructure, (i.e. connections between buildings) accomplished very early in the project cycle. This assessment is of particular importance if demolition of any structure is required as part of the overall project, and/or the new project may impact an existing conduit infrastructure.

3.12 Tenant Improvement Project

- A. As part of the construction process for leased space, plans shall be made to remove any existing cable that may otherwise become abandoned.
- B. Abandoned cables, not identified and labeled for future use, increase the fire fuel load and shall be removed in accordance with the 2002 National Electrical Code.
- C. CR shall be contacted and requested to survey the existing cable plant. There is a possibility that all or a portion of the existing installed cable may be reusable.

3.13 Construction Documents

The A&E Project Manager shall ensure that CR has the opportunity to review and comment on all drawings and/or specifications that have any impact on the Telecommunications Infrastructure.

Section 4.0 Electrical Requirements

4.1 Design Requirements

A. Following are the basic guidelines for the electrical design consultant. These design guidelines are considered to be minimum requirements. The electrical design consultant shall contact A&E to determine if there are any additional or special requirements. CR requires this information be included in drawings and specifications. If the current Construction Specifications Institute (CSI) Master Format™ is used, a separate section within the current Electrical Division shall be used to address:

1. Conduits for telecommunications use.
2. Work Area Outlet (WAO) and pull boxes for telecommunications use.
3. Telecommunications cable support system (cable tray and J-hook).
4. The telecommunications grounding system.
5. Testing requirements.

B. These sections and drawings shall be made available to CR.

4.2 Telecommunications Space (TS) Electrical Requirements

A. A 60-amp sub-panel or dedicated circuits shall be installed in all ADF/BDF/IDF (ER/TR) rooms. The estimated electrical load for the telecommunications space shall not exceed 80% of the panel. At a minimum, **ALL** TS's shall be provided dedicated electrical service.

B. Dedicated power circuits from shared panel boards shall be provided with both transient voltage surge suppression and electrical high frequency noise filtering. Finish color shall be Blue.

C. If a low number of telecommunications spaces are planned, one electrical panel may serve multiple telecommunications spaces as a design alternative.

D. Sub-panels shall be located near the room entrance door, whenever possible, to conserve wall space and should be connected to an emergency power source whenever such a source is provided to the building.

E. Convenience duplex receptacles shall be:

1. Mounted in each room at +18-inches AFF and horizontally spaced not to exceed 6-feet around the perimeter of the room.

2. Non-switched, 120VAC 20 Amp, duplex and divided equally on branch circuits, (i.e. all receptacles in the same room shall not all be on the same circuit). No more than four (4) receptacles shall be on the same circuit.

3. Each receptacle shall be clearly marked with its respective circuit number.

F. If the room has a raised floor, all under floor receptacles shall be side mounted on a flex whip not to exceed 30-inches in length. All circuits for under floor receptacles shall be of a ground-fault interrupter type.

G. HVAC systems shall not use the same electrical panel that is used to support telecommunications spaces.

4.3 Equipment Rack and Cabinet Electrical Requirements

A. Equipment racks identified for electronic equipment shall have the following installed:

1. One (1) quad device box containing two (2) duplex 20 Amp, 120V AC NEMA 5-20R-spade receptacles located on separate dedicated circuits in the room sub-power panel.

2. Device box shall be mounted on the backside of each rack 15-inches Above the Finished Floor (AFF). The placement of this device box and its EMT conduit **shall not** block or interfere with the equipment mounting area (rails) on either side of the rack.

3. Flexible conduit shall be used to attach electrical service to the equipment rack. Flexible conduit is required to prevent the shearing of the conduit during a seismic event.

4. Reference Specification 07, Equipment Racks and Distribution Cabinets, Figure 07-1.

B. Enclosed cabinets identified for electronic equipment shall have the following installed:

1. Two (2) quad device boxes containing two (2) duplex 20 Amp, 120V AC NEMA 5-20R-spade receptacles to separate dedicated circuits located in the room sub-power panel.

2. One (1) device box shall be mounted toward the back of the cabinet near the top inside area of the cabinet to provide electrical power to the cooling fan(s). The second device box shall be located 15-inches above the floor toward the back of the cabinet.

3. The device boxes and EMT conduit **shall not** block or interfere with the equipment mounting area (inside and outside mounting rails) within the cabinet.

4. Reference Specification 07, Equipment Racks and Distribution Cabinets, Figure 07-2.

C. Special considerations:

1. ADF equipment racks and cabinets shall have 30 Amp, 120V AC NEMA 5-30R-spade receptacles in place of the 20 Amp, 120V AC NEMA 5-20R-spade receptacles.
2. Provide a duplex 20 Amp, 220V receptacle for a DLC cabinet. Contractor may be required to hard wire the 20 AMP circuit into the cabinet equipment.

4.4 Electromagnetic Interference

The TS **shall not** be located near electrical power supply transformers, elevators, pump motors, generators, x-ray equipment, radio transmitters, radar transmitters, induction heating devices or other potential sources of electromagnetic interference (EMI).

4.5 Emergency Back-up Power

- A. Sub-panels shall be connected to an emergency power source whenever such a source is provided to the building.
- B. Emergency power is especially important in the TS's that house Digital Loop Carrier systems to ensure voice and emergency systems remain operational during power outages that may extend past the systems battery backup capability.

4.6 Grounding

- A. In addition to the normal electrical ground system, a Main Telecommunications Ground Busbar (MTGB) and a Telecommunications Ground Busbar (TGB) system is required per ANSI/EIA/TIA-STD-J-607-A. These grounding systems shall be installed to support the telecommunications infrastructure.
- B. A TMGB shall be located in the ER (ADF/BDF). The TMGB is to be bonded to the electrical panel ground bus bar and to building steel or ground rod by conventional welds, exothermic welds clamp-and-braze method, or UL approved compression type connectors where practical. The connection between the TMGB and the bonding point shall be 6 AWG copper ground wire or larger as required. Exothermic welds are the preferred method.
- C. In each TR (IDF), a TGB shall be installed. The TGB shall be bonded to the electrical panel serving the area where the TGB is installed, bonded to building steel and bonded in series to the main TMGB.
- D. All TMGB's and TGB's shall be labeled in accordance with TIA/EIA 606-A. Reference Specification 08, Electrical Protections, Bonding and Grounding, Figure 08-1.

E. All ground cables shall have a plastic "Ground Warning Label" attached.

4.7 Telephone Terminal Board

A. All walls shall be lined with trade size, void free, 3/4-inch AC-grade plywood, 8-foot high.

B. The plywood shall be securely fastened to the wall-framing members. Wall anchors shall be flush to the plywood surface as to not obstruct the mounting of cabling hardware. The walls shall be capable of supporting the attached equipment.

C. Plywood sheets shall be either:

1. Fire Rated by the manufacturer and painted with two coats of white paint. At least one (1) Fire-Rated stamp shall be visible per sheet or partial sheet of plywood when painting is completed.

2. AC-grade painted with two coats of white Fire-Retardant paint. A CR representative shall be present at the time of painting to confirm and verify the use of Fire-Retardant paint.

D. Plywood shall be mounted vertically, in full-sheets, starting at 2-inches above the finished floor (6-inches above the finished floor when installing a standard vinyl baseboard).

4.8 Raised Floor Bonding and Grounding

If a raised floor is present, then the raised floor bonding system shall meet the requirements of the most current California Electric Code.

4.9 TS Layout (General)

A. Locate sleeves, slots, and/or conduits on the left side of the wall. This placement enhances the use of wall space from left to right.

B. Trays and conduits located within the ceiling shall protrude into the room a distance of 1 to 2-inches without a bend and above 8 ft. high.

C. Reference Figure 4-1 for a typical TS (ADF/BDF/IDF) layout.

NOTE The type and location of the cross-connect fields may influence the optimal placement of pathways.

4.10 Fire Stop Penetrations

- A. The project drawings shall show the type of firestop penetration systems to be used. This information may be displayed in the form of a drawing detail.
- B. All systems shall be sealed and labeled at the time of installation. Reference Figure 4-2.
- C. All firestopping labels shall conform to all requirements listed in the ANSI/TIA/EIA 606-A standard. Reference Figure 4-3.
- D. Do not cover up through-penetration firestop system installations that will become concealed behind other construction until a University inspector has examined each installation.
- E. Any existing firestopping material that has been disturbed or removed during a cable installation shall be restored and/or replaced to meet local code requirements.
- F. Any and all excess fill material adjacent to openings shall be cleaned with a cleaning material approved in writing by the firestop system manufacturer.

Figure 4-1 Typical TS (IDF) Layout

SHEET NOTES:

- 1) DUPLEX CONVENIENCE RECEPTICLES SHALL BE PLACED EVERY 6' AND MOUNTED AT 18" AFF AROUND THE PERIMETER OF THE ROOM
- 2) MOUNT 2 EACH 20 AMP DEDICATED BRANCH CIRCUIT WITH 15 AMP DUPLEX OUTLETS IN QUAD BOX MOUNTED AT 15" AFF IN BACK OF EACH RACK IDENTIFIED FOR ELECTRONIC EQUIPMENT
- 3) LADDER RACK SHALL BE 12" WIDE AND MOUNTED AT 7'-6" AFF. SUPPORTED WITH 1/2" THREADED ROD FROM ABOVE SLAB EVERY 5'
- 4) OPEN EQUIPMENT RACKS SHOWN, IF DATA CABINETS ARE USED, MAINTAIN SAME DISTANCE FROM WALLS DO NOT JOIN EQUIPMENT RACKS OR CABINETS TOGETHER. EQUIPMENT RACKS AND CABINETS SHALL MOVE SEPERATE OF EACH OTHER
- 5) OVERHEAD LADDER RACK FOR CABLE ROUTING RACK SHALL NOT BE ATTACHED TO THE EQUIPMENT RACKS OR CABINETS
- 6) 6" SINGLE SIDED CABLE MANAGEMENT SECTIONS BETWEEN AND AT EACH END OF RACK. CABLE MANAGEMENT BETWEEN RACKS SHALL NOT BE JOINED TOGETHER.
- 7) SLEEVES SHALL ENTER AT 8' AFF AND IN-LINE WITH OVERHEAD LADDER RACK
- 8) ALL WALLS LINED WITH 3/4" VOID-FREE A/C GRADE PLYWOOD MOUNTED WITH A GRADE FACING OUT (FIRE RATED AND PAINTED ON ALL SIDES WITH TWO COATS OF FIRE-RESISTANCE PAINT, DO NOT PAINT OVER STAMP)
- 9) A MINIMUM OF 2'-6" CLEARANCE SHALL BE MAINTAINED AT ONE END OF ROW

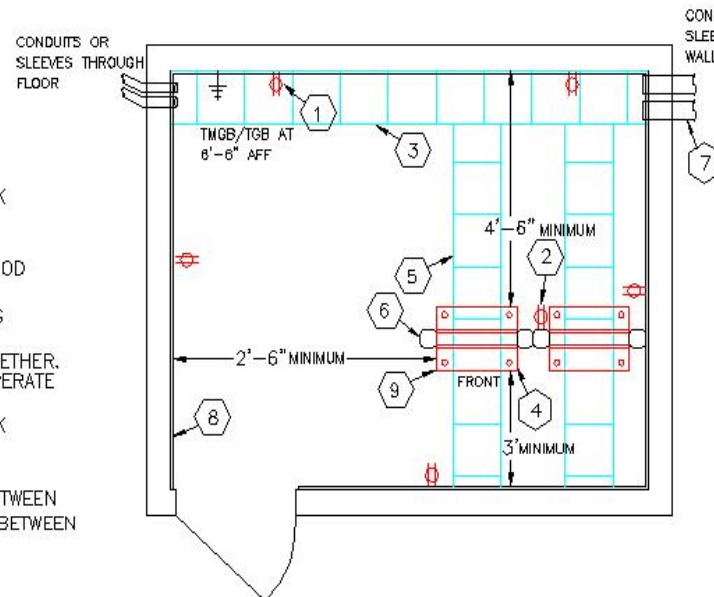

Figure 4-2 Firestopping Requirements

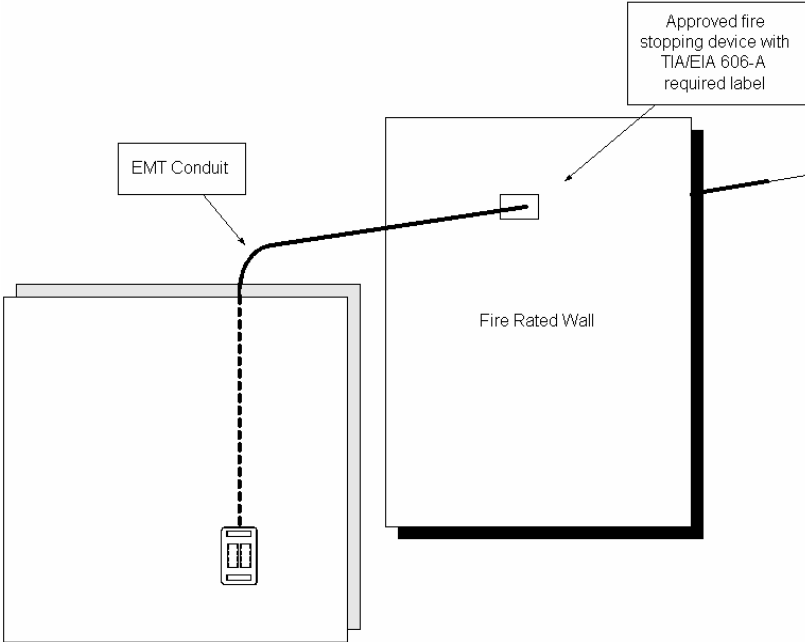

Figure 4-3 Firestopping Label



4.11 Communication Pathways.

- A. The primary types of horizontal pathways are:
 1. In-floor ducts (one- level or two- level).
 2. Cellular floors.
 3. Conduit.
 4. Access (raised) floors.

5. Ceiling distribution.

B. Many buildings require a combination of the above systems. The CR standard for a combined system is an overhead distribution method based on the use of a cable tray and J-hook system for routing and an EMT conduit stub-up to the WAO device boxes.

4.12 Cable Support (General)

A. The main routing and support systems for communication cables on the UC Davis campus are:

1. Cable tray system (hallways)
2. J-hooks and adjustable cable support (bags) (accessible false ceiling areas)
3. Conduit home runs (hard ceiling areas, inaccessible ceiling area's, in-floor boxes, masonry walls)

B. The use of a wire basket tray system is the preferred method. A minimum 12-inches of clearance shall be provided above the cable tray and a minimum clearance of 12-18-inches on at least one side shall be provided.

C. The use of deep cable trays, commonly used for electrical cables, **shall not** be used due to the limited amount of space in the ceiling areas.

D. All cable trays shall have seismic bracing as designed by a California licensed structural engineer.

E. The use of conduit home runs from the WAO to the TS is the preferred method of providing cable support.

F. All cable trays and J-hooks shall be dedicated for CR use only. No other building cabling system (800 MHz radio, access control, building automation, etc) is to share these cable trays and J-hooks.

4.13 Work Area Outlet (WAO)

4.13.1 WAO Density

A. A minimum of two WAO's containing one Voice and Data NAM shall be installed in each typical office area. For planning purposes, space allocated per typical office area averages 100 ft sq.

B. WAO's shall be located as to offer maximum flexibility for change within the work area (e.g. on opposing walls).

C. For building areas where it is difficult to install additional WAO's at a later date (e.g. laboratories, private office space, etc), additional WAO's shall be provided in the initial design for that area.

D. WAO locations shall be coordinated with the furniture layout. Power receptacles shall be installed within 3-feet of each WAO. WAO locations are typically at the same height as the power receptacle.

4.13.2 WAO Device Boxes

A. WAO's shall have a standard 4-inch square by 2-1/8-inch deep device box installed inside the walls. The minimum size of conduit shall be 1-inch. Typical mounting height shall be +18-inches AFF for WAO's in office areas, or to match the height of existing power receptacles, where appropriate.

1. WAO's may be placed above the normal desk height, where appropriate.

2. WAO's located in hose or wash-down areas shall be installed at a height above the anticipated damp area, and shall include a UL Listed NEMA rated water resistant cover.

B. WAO's that support Fiber to the Desktop (FTTD) installations shall have an additional 1-1/2-inch device box extension installed in the front of the standard device box. This extension is required to deepen the device box and maintain the fiber optic bend radius. A dual gang mud ring shall be installed on the front to accommodate an 8-port faceplate if voice, data and/or video NAM's are planned for the same location.

C. Wall mounted telephones shall have a standard 4-inch square by 2-1/8-inch deep square device box installed. The minimum size of conduit shall be 1-inch. The device box shall be mounted at +42-inches AFF for a wall-mounted telephone.

D. Interior public payphones shall have a 4-inch square by 2-1/8-inch deep device box installed. The minimum size of conduit shall be 1-inch. The device box shall be mounted at +42-inches AFF.

E. The above device boxes shall be all steel construction, UL listed and have a single gang mud ring installed, unless otherwise noted.

4.13.3 WAO Floor Mounted Boxes

In open office areas, floor mounted boxes shall be used as cable feed points to the module workstations. The typical box shall be a minimum 4-inch square by 2-1/8 inch deep device box. The minimum size of conduit shall be 1-inch.

4.14 Interior Conduits

4.14.1 Conduit Size

A. All WAO's shall have a minimum of one (1) 1-inch trade size Electrical Metallic Tubing (EMT) conduit installed from the device box to within 6-inches of an installed J-hook or cable tray.

B. All FTTD WAO's shall have a minimum of one (1) 1-1/4-inch trade size Electrical Metallic Tubing (EMT) conduit installed from the device box to within 6-inches of an installed J-hook or cable tray.

C. Wall-mounted courtesy and public pay telephones shall have a minimum of one (1) 1-inch trade size EMT conduit installed from the device box to within 6-inches of an installed J-hook or cable tray.

D. Floor-mounted WAO's shall have a minimum of one (1) 1-1/4-inch trade size EMT conduit installed from the device box to within 6-inches of an installed J-hook or cable tray. A minimum of (1) one EMT conduit shall service each individual floor box. Floor boxes **shall not** be looped or daisy-chained together with one single conduit, regardless of the size of conduit.

E. The maximum allowable conduit fill requirements shown in Table 4-1 shall be adhered to when designing conduit installations for WAO device box and Wiremold® locations.

F. Interior conduits and/or sleeves shall be properly sized in accordance with TIA/EIA 569-B, Table 4-1.

4.14.2 Installed interior conduits shall:

A. Be installed in the most direct and accessible route possible (parallel to building lines and located in and above accessible hallways).

B. Contain no more than two 90-degree bends in any dimensional plane or exceed 100-feet in length between pulling points or interior pull boxes.

C. Contain an accessible pull box for lengths that contain more than the equivalent of two 90-degree turns in any dimensional plane.

D. All conduits and conduit stub-ups shall have a minimum bend radius 6 times the outside diameter of the conduit (2-inches and less), and 10 times the diameter of the conduit (2 1/4-inches and greater). Reference Table 4-2. For additional information on conduit bend radius requirements and recommendations, see specifications in ANSI/NFPA 70 and ANSI/TIA/EIA-569-B.

E. Install pull string (also called a pull cord) in all conduits with a minimum test rating of 200 lb.

F. Stub up all conduits to within 6-inches of the J-hook or cable tray from a device box.

G. Conduits shall stub up to an accessible ceiling area.

H. All conduits shall be reamed at both ends and have a plastic bushing installed on each end to prevent damage during cable installation.

I. Wall-mounted riser conduits and/or sleeves entering a Telecommunications Space (ER/TR) shall have a plastic spillway installed onto the end of the conduit to prevent kinking of the installed cable bundle. BEJED, Inc. part number BJ-2049B-002, or equal. www.bejed.com

J. All conduits shall be bonded and grounded in accordance with the CEC, where applicable.

K. All conduits shall adhere to the maximum allowable conduit fill for cables as shown in Table 4-1.

L. All conduits shall be labeled in accordance with ANSI/TIA/EIA 606-A. Reference Figure 4-3.

Table 4-1 Maximum Allowable Conduit Fill

Conduit Trade Size		Maximum Number of Cables Based Upon 40% Allowable Fill									
		Cable Outside Diameter mm (inches)									
		3.3 (.13)	4.6* (.18)	5.6 (.22)	6.1 (.24)	7.4 (.29)	7.9 (.31)	9.4 (.37)	13.5 (.53)	15.8 (.62)	17.8 (.70)
16	½	1	1	0	0	0	0	0	0	0	0
21	¾	6	5	4	3	2	2	1	0	0	0
27	1	8	8	7	6	3	3	2	1	0	0
35	1 ¼	16	14	12	10	6	4	3	1	1	1
41	1 ½	20	18	16	15	7	6	4	2	1	1
53	2	30	26	22	20	14	12	7	4	3	2
63	2 ½	45	40	36	30	17	14	12	6	3	3
78	3	70	60	50	40	20	20	17	7	6	6
91	3 ½							22	12	7	6
103	4							30	14	12	7

* The Outside Diameter of Berk-Tek LANMARK 350™ CMR

Table 4-2 Conduit Bend Radiuses

Internal Diameter	Minimum Bend Radius
2 inches or less	6 times the internal conduit diameter
2 1/4 inches or more	10 times the internal conduit diameter

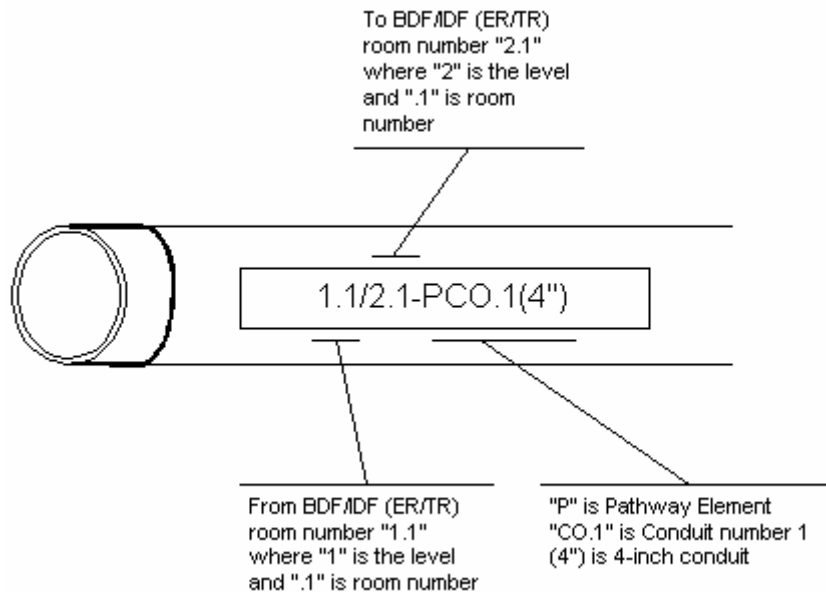
Figure 4-3 Conduit Labeling**4.14.3. Installed conduits shall not:**

- A. Contain more than two 90-degree bends between pulling points.
- B. Contain any LB type fittings.
- C. Contain any continuous lengths or sections longer than 100-feet.
- D. Be installed in or have a stub-out located in an inaccessible hard ceiling area.
- E. Contain a pull box in place of a conduit sweep.
- F. Be installed through areas in which flammable materials may be stored, or over and adjacent to boilers, incinerators hot water lines or steam lines.

Note: For runs that total more than 30 m (100-feet) in length, insert pull points or pull boxes so that no segment between pulling points exceeds the 100-foot limit.

4.14.4 Structures to Support Vertically Aligned TS's

- A. Vertically aligned TS's shall utilize sleeves and slots.
- B. In a multistory building, grip brackets shall be specified to support the riser cable's weight as it passes through the ER/TR.
- C. Sleeves and slots **shall not** be located on the same wall as light switches and temperature controls if there is a possibility of the cable bundles blocking or interfering with these devices.

D. Vertical cable runway or mesh wire type trays shall be installed behind the sleeves and slots to allow for proper cable management.

E. Table 4-3 shows the conduit fill ratio requirements for riser cables.

Table 4-3 Maximum Fill Requirements for Riser Cable

*Internal diameters are taken from the manufacturing standard for electric metallic tubing and rigid metal conduit.

Conduit		Area of Conduit		
Trade Size (Inches)	Internal Diameter* (Inches)	Maximum Recommended Fill		
		1 Cable 53% Fill (in ²)	2 Cables 31% Fill (in ²)	3 Cables 40% Fill (in ²)
1	1.05	0.46	0.27	0.35
1¼	1.38	0.79	0.46	0.60
1½	1.61	1.08	0.63	0.81
2	2.07	1.78	1.04	1.34
2½	2.47	3.11	1.82	2.34
3	3.07	4.69	2.74	3.54
3½	3.55	6.12	3.58	4.62
4	4.03	7.82	4.57	5.90

4.14.5. Structures to Support Horizontally Offset TS's

A. TS's that are not vertically aligned shall be connected with cable trays, conduits and pull boxes.

B. Cable trays that are used to support horizontal cabling may be used to support riser cables provided the following conditions are met:

1. The cable trays carrying capacity can accommodate the riser cables.
2. The route of the cable trays can be used or modified to accommodate the lateral run between the IDF and the WAO's.
3. Cable trays shall be labeled in accordance with TIA/EIA 606-A. Reference Figure 4-5.
4. Cable trays shall be bonded and grounded in accordance with ANSI-J-STD-607-A.

C. Conduit shall be used to route the riser cables between the BDF/IDF located in the ER/TR if cable trays are not used to support the horizontal cabling. Conduit paths are tightly controlled pathways that shall be coordinated with other trades during construction or remodeling.

1. The conduit shall be Rigid Steel Conduit (RSC) or Electrical Metallic Tubing (EMT), 4-inches in diameter.
2. The conduit shall be installed with a pull string and each end shall contain a plastic bushing to protect the cable.
3. Conduits that enter the ER/TR shall be placed near the corner and as close as possible to the wall where the backboard is mounted to allow for proper cable racking and to minimize the cable route inside the ER/TR.
4. Conduit located in the ceiling shall protrude into the ER/TR 1 to 2 inches and a minimum 7½ feet above the finished floor. Conduit shall not turn down.
5. Conduits shall be bonded and grounded in accordance with ANSI-J-STD-607-A.
6. Reference Table 4-3 for details on conduit fill for riser cables.

Note: A 1-inch conduit shall be dedicated from the ER/TR to a sealed junction box on the roof of the building for the installation of an 800 MHz antenna cable. This conduit shall be grounded using a path other than the telecommunications ground provided in the ER/TR.

- D. Identify on the floor plans the BDF/IDF's that shall be supported using conduit and determine the number of conduits required.
- E. Sketch the proposed route of the conduit on the floor plan.
- F. Conduits shall be labeled in accordance with TIA/EIA 606-A. Reference Figure 4-3.

4.15 Communications Cable Runway and Trays

4.15.1 Cable Runway

- A. Cable runway shall be used only in Telecommunications Spaces (TS).
- B. Cable runway shall be secured on 10-foot centers using an angled wall support and standard trapeze type support system in accordance with manufacturer specifications and applicable California Building and Electrical (CBC, CEC) Codes.
- C. Cable runway shall be aluminum or steel type. All cable runway shall be a minimum 12-inches wide.
- D. Cable runway and trays shall be bonded end-to-end. Cable runway and trays **shall not** be used as an equipment ground nor seismic support or bracing.

E. Cable runway shall not be placed within 5-inches of any overhead light fixture and within 12-inches of any electrical ballast. A minimum clearance of 12-inches above the cable ladder shall be maintained at all times. All bends and T-joints in the cable ladder shall be fully accessible from above (within one foot).

F. Cable runway shall meet the requirements in TIA/EIA 569-B and applicable addendums, to include the latest Addendum 7, Cable Trays and Wire ways, dated December 2001.

G. Cable runway shall be grounded and bonded in accordance with ANSI/TIA/EIA-J-STD-607-A. All splices, T-Sections and bends shall be bonded together.

H. Cable runway shall meet Zone 4 or higher seismic bracing standards, where required.

4.15.2 Cable Trays

A. Cable trays shall be secured on 10-foot centers using a single center-mounted steel supporting rod and bottom "T" connector, angled wall supports or a standard trapeze type support system in accordance with manufacturer specifications and applicable California Building and Electrical codes.

B. Cable trays shall be steel wire basket or mesh suitable for hallways and false ceiling areas. All cable trays shall be a minimum of 12-inches wide and 2-inches deep.

C. Cable trays shall be sized to accommodate future Fiber to the Desktop installations and building growth.

D. Cable trays shall meet Zone 4 or higher seismic bracing standards where required.

E. Cable trays shall be installed in accessible ceiling areas only, and shall transition to a minimum of three 4-inch EMT conduits when routed over fixed, hard and inaccessible ceiling spaces. Reference Figure 4-4.

F. Deep aluminum type cable trays **shall not** be used due to ceiling space and accessibility limitations.

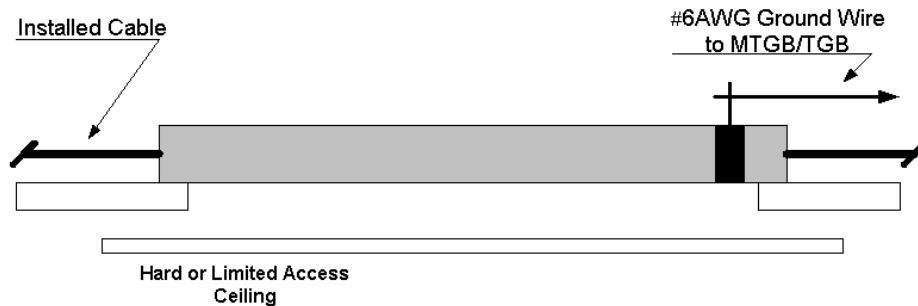
Figure 4-4 EMT Conduits Placed Above Hard or Limited Access Ceiling

F. Cable trays shall be grounded and bonded in accordance with ANSI/TIA/EIA-J-STD-607-A. All splices, T-Sections and bends shall be bonded together. Cable trays **shall not** be used as an equipment ground.

G. Cable trays shall extend 6-inches into the TS (ER/TR) then utilize a manufacturer's radius drop out (waterfall) to protect station cables from potential damage from the end of the tray.

H. All cable tray penetrations through firewalls shall allow cable installers to firestop around the cables after they are installed. Tray-based mechanical firestop systems shall be used when a cable tray penetrates a fire barrier. All firestopping installations shall be labeled in accordance with ANSI/TIA/EIA 606-A.

I. Cable trays shall not be placed within 5-inches of any overhead light fixture and within 12-inches of any electrical ballast.

J. A minimum clearance of 12-inches above and 12 to 18-inches to one side of the cable tray shall be maintained at all times. All bends and T-joints in the cable trays shall be fully accessible from above (within one foot).

K. Cable trays shall be mounted no higher than 12-feet above the finished floor, and shall not extend more than 4-feet over a fixed ceiling area.

L. Plenum mesh type trays shall be used in plenum ceiling areas.

M. Installed cable trays shall meet the requirements in TIA/EIA 569-B and applicable addendums, to include the latest Addendum 7, Cable Trays and Wireways, dated December 2001.

N. Cable trays shall be labeled in accordance with TIA/EIA 606-A. Reference Figure 4-5.

O. Cables installed in cable trays **shall not** contain, nor be fastened with Velcro or plastic type cable ties (tie-wraps).

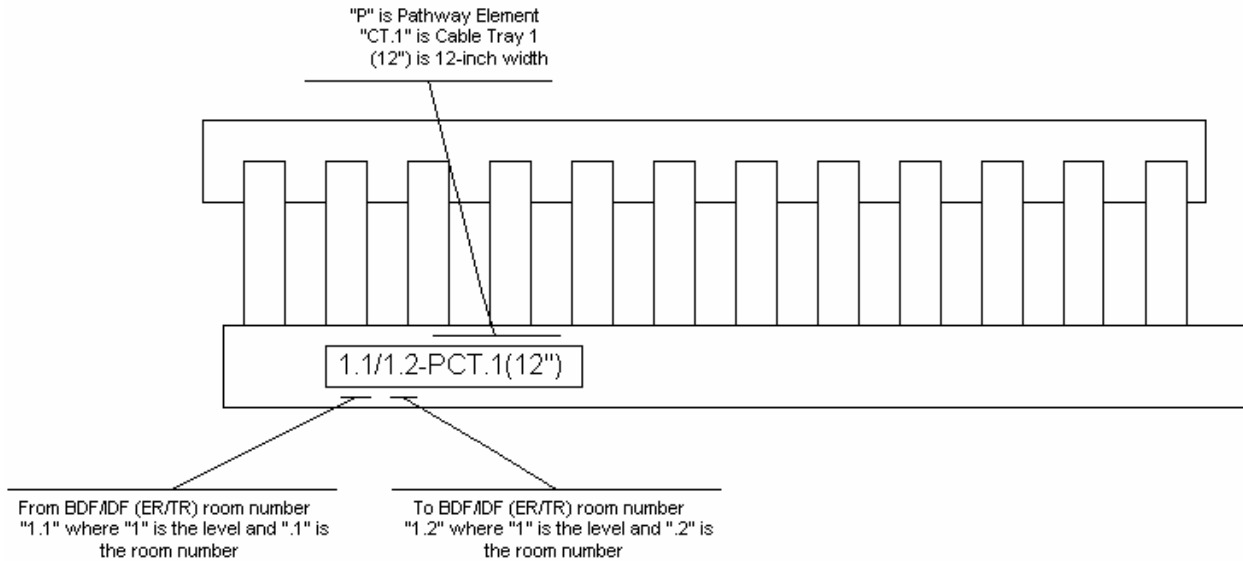
Figure 4-5 Cable Tray Labeling

4.16 Communications J-Hooks

- The installation of the J-hooks should be included in the same project section as the installation of the communications cables.
- J-hooks shall be spaced at a **maximum** of 48-inches to 60-inches apart, and within 6-inches of an EMT conduit stub-up.
- J-hooks shall be dedicated for CR use only. No other building cabling system (800 MHz Radio, A/V and MATV systems, building access control, building automation systems, etc) is to share the J-hooks installed for voice and data cabling. Additional J-hooks shall be planned and installed to support these additional cabling systems.
- Location of J-hooks shall be indicated on the Electrical Design and/or Telecommunications drawings.
- The number of cables supported by a J-hook shall not exceed the manufacturer's recommendation.
- Cables **shall not** be secured to the J-hook with cable ties or vinyl tape.

4.17 Communication Floor Poke-Through Devices

- All floor poke-through devices shall be indicated on the electrical and/or telecommunications drawings with the size of conduit to be installed.

B. Devices shall be UL Listed and UL Fire Classified to U.S. safety standards for tile and terrazzo, and the meet or exceed the UL requirement for the scrub water exclusion test for carpet and wood floors.

C. Accept industry standard devices to provide a seamless and aesthetically pleasing interface for voice, data, audio, and video applications at the point-of-use.

D. Suitable for use in air handling spaces in accordance with Sec 300-22(C) of the National Electrical Code.

E. Meets ADA accessibility guidelines.

F. Products shall be Walker In-Floor systems as manufactured by Wiremold or equal.

4.18 Floor Boxes

A. Floor boxes shall be installed in easily accessible locations.

B. Floor boxes shall be installed with a minimum of 1-1/4-inch EMT conduit dedicated to each floor box.

C. Floor boxes shall be located in such a manner the box can be accessed during working and non-working hours.

D. Floor boxes shall not be used in lieu of a bend for a conduit's change in direction. Boxes shall be installed either before or after a bend in a conduit.

F. Floor boxes shall not be daisy-chained together, nor shall one conduit service more than one box.

4.19 Pull Boxes

A. Installing pull boxes:

1. Pull boxes shall be installed in easily accessible locations.

2. Pull boxes shall be placed in an interstitial ceiling space only if it is listed for that purpose and it is placed above a suitably marked, removable ceiling panel.

3. Horizontal cabling boxes shall be installed immediately above easily accessible suspended ceilings.

4. Pull boxes installed shall be located in such a manner the pull box can be accessed during working and non-working hours.

5. Pull boxes shall not be located in restricted and/or highly secured areas, such as X-Ray rooms, Clean rooms, etc.

6. Pull boxes shall **not** be installed in lieu of a bend in a conduit. Boxes shall be installed immediately before or after a bend in conduit.

7. Reference Figure 4-6 for pull box configurations.

B. Choosing a pull box

1. For horizontal cable, the width and depth of the pull box shall be adequate for fishing, pulling and looping the cable. The length shall be 12 times the diameter of the largest conduit. Reference Figure 4-7.

2. Use Table 4-4 to select the proper size of pull box.

Figure 4-6 Pull Box configurations

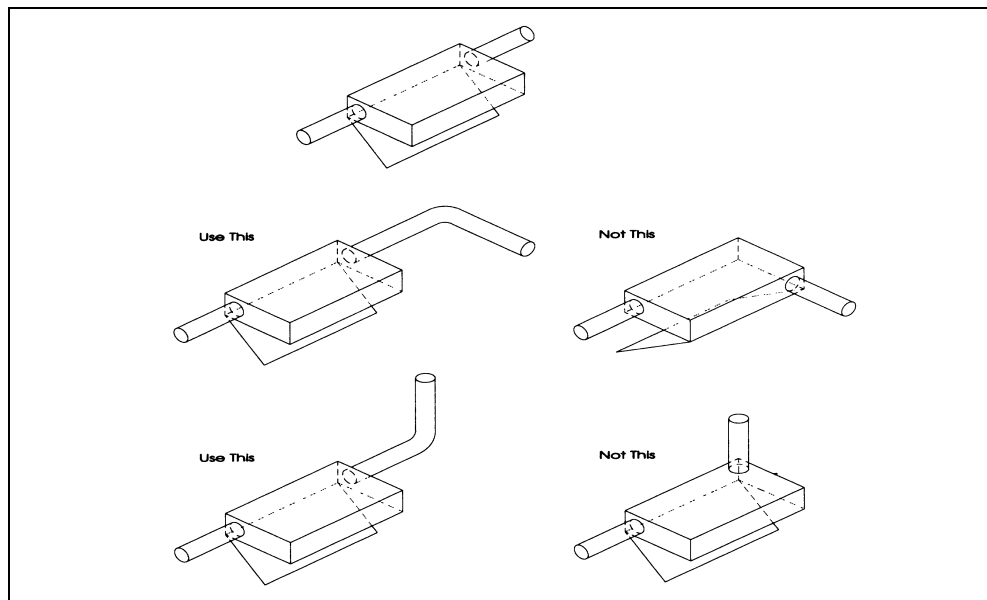

Figure 4-7 Measuring a Pull Box

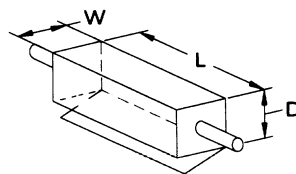

Table 4-4 Sizing a Pull Box

Maximum Trade Size of Conduit (Inches)	Size of Box			For Each Additional Conduit Increase Width (Inches)
	Width	Length	Depth	
.75	4	12	3	2
1.0	4	16	3	2
1.25	6	20	3	3
1.5	8	27	4	4
2.0	8	36	4	5
2.5	10	42	5	6
3.0	12	48	5	6
3.5	12	54	6	6
4.0	15	60	8	8

Section 5.0 Mechanical (HVAC)

5.1 Design Process

Following are the basic guidelines for the mechanical design consultant. These design guidelines are considered to be minimum requirements. The Heating, Ventilation and Air Conditioning (HVAC) consultant shall contact CR to determine if there are any other special requirements.

5.2 HVAC Requirements

A. The air handling system and environment controls for TS's shall be continuous and dedicated and designed to provide positive airflow and cooling even during times when the main building systems are shut down. This may require separate air handlers and/or small stand-alone cooling systems that are thermostatically controlled in this space. Whether this space is separate or combined with the building service entrance, it is by almost every definition, a specialized area. The room will house sensitive electronic components that will generate heat 24 hours a day, 365 days a year and must be cooled to maintain operating performance.

B. If the building's HVAC system cannot meet this requirement, then a stand-alone HVAC system with independent controls for heating, ventilation, and air conditioning sensors and control equipment related to the environment within the TS shall be located in the TS.

C. The HVAC unit will not be powered off the same electrical panel as the telecommunications spaces.

D. Final BTU load estimates can be provided after the equipment has been selected. For maximum planning purposes, assume at least 5,000 BTUs per equipment rack/cabinet to be installed. A typical telecommunications space contains at least three racks, with one rack dedicated to electronics.

E. In larger or critical installations, such as Area Distribution Frames (ADF), the air conditioning system (or that part of a larger system) may have to be connected into a backup generator system. Provisions shall be made so the telecommunications equipment will not "thermal out" or overheat due to a loss of power to the air conditioning system. Check with CR to see if this condition exists.

F. A positive pressure differential with respect to the surrounding areas shall be provided.

G. The ambient temperature and humidity shall be measured at the distance of 5-feet above the floor level. After the equipment is in operation, the measurement can be taken at any point along an equipment aisle centerline. The normal temperature range is 64-degrees F to 74-degrees F with a humidity range of 35% to 55% relative.

H. The TS shall be protected from contaminants and pollutants that could affect operation and material integrity of the installed equipment. When contaminants are present in concentrations greater than indicated in ANSI/TIA/EIA-569-B, Table 8.2-2, vapor barriers, positive room pressure or absolute filters shall be provided.

I. The UC Davis A&E office shall ensure the TS environmental systems are tested and certified, any/all construction filters have been removed and replaced with appropriate system filters, and that they meet the TS environmental requirements.

5.3 Fire Smoke Dampers

If the room is fire-rated, fire/smoke dampers shall be required for supply and exhaust air.

Section 6.0 Communication Designers

6.1. Design Process

The primary role of the Communication Designer is to:

A. Develop a telecommunications cabling design based upon industry codes, ANSI/EIA/TIA Standards, BICSI Design Manuals and the CR Telecommunications Standards document.

B. The Design Documents shall include, but may not be limited to the following:

1. Legend
2. Site Plan (can be part of the electrical site plan) showing OSP conduits and maintenance and hand holes, etc.
3. Floor plans showing the type and number of communication cable(s) to be installed at each WAO
4. Cable Infrastructure (cable pathway, WAO locations, conduit, cable tray or J-hook routing (can be part of the electrical drawings)
5. Enlarged telecommunications space plans
6. Single line drawing details
7. Cable installation design specifications

6.2. Equipment in Telecommunications Spaces

Before actual design work commences, it is recommended the communication consultant meet with CR to determine what active equipment, such as network switches, Digital Loop Carrier (DLC), UPS systems, etc., will be installed in this facility. The installation of network switches and DLC equipment will require the inclusion of a Telecommunications Equipment Room in the design. If multiple Telecommunications Spaces (ADF/BDF/IDF) are required, then A&E shall be advised so the additional space requirements can be accommodated.

6.3. The Horizontal Segment

6.3.1. The Design Process

A. The horizontal segment consists of two elements:

1. The horizontal cable and connecting hardware that provide the means for transporting the telecommunications signals between the Work Area Outlet (WAO) and the Intermediate Distribution Frame (IDF).

2. The horizontal cabling pathways and spaces that distribute and support the horizontal cable and connecting hardware between the WAO and the IDF.

Note: Cables that interconnect IDF's on the same floor, while physically horizontal in orientation, are considered part of the riser segment.

B. This section describes the policies and procedures for the following design activities:

1. Determining the type and number of WAO's and NAM's in the work area.
2. Identifying the types and lengths of cable used in the horizontal segment.
3. Determining NAM termination hardware requirements at the WAO.
4. Designing the structures needed to support the horizontal cabling.
5. Assigning the NAM numbers to the appropriate locations.
6. Cable testing procedures.

6.3.2. The Type and Number of NAM's

A. Network Access Module (NAM) at UC Davis refers to the type of module installed in the WAO faceplate. A NAM can be an 8-position, 8-contact (8P8C) modular jack for voice or data, an F-type connector for video or an LC-type connector for Fiber to the Desktop (FTTD).

B. A WAO with one (1) NAM shall support one (1) voice, data or video application. It consists of a single NAM (Fog White 8P8C for Voice, Orange 8P8C for Data or F-type for Video) supported by one 4-pair Unshielded Twisted Pair (UTP) Category 5e cable (White sheath for Voice or Blue sheath for Data) or an RG-6 coax for video. This configuration shall be used for a wall phone, a desk courtesy phone, a card reader, video connection or to augment an existing work area with additional voice, data or video capacity.

C. The most common WAO configuration used on the UC Davis campus supports both voice and data applications. It consists of two (2) NAM's (one (1) Voice 8P8C and one (1) Data 8P8C) per WAO supported by two 4-pair UTP Category 5e cables placed within a 4-port faceplate. Each 4-pair UTP Category 5e cable supports only one (1) NAM. The splitting of the voice UTP cable conductors between multiple voice NAM's is not permitted.

D. A Fiber to the Desktop (FTTD) WAO shall consist of a 4-port faceplate with an expanded electrical device box inside the wall that allows for proper fiber bend radius, two (2) duplex LC type fiber optic inserts and one (1) 4-strand indoor Single-mode fiber optic cable. Reference Appendix A Specification 01, WAO Faceplates, Surface Mount Boxes, Wiremold® Adapter and Modules, for additional information.

E. A combination of voice, data, video and FTTD NAM's may be used at one (1) WAO location with the properly sized faceplate. Reference Appendix A Specification 01, WAO Faceplates, Surface Mount Boxes, Wiremold® Adapter and Modules, Table 01-1 for a list of approved faceplates.

F. A minimum of two (2) WAO's, each with voice and data capability shall be provided in each office and conference room.

G. A minimum of one (1) WAO with two (2) voice NAM's shall be provided adjacent to the building fire alarm panel. This NAM shall consist of a surface mounted outlet box with a two-port faceplate and individually cabled Fog White, T568A, Cat 5e type 8P8C modules. These cables shall be terminated at the voice 110-type patch panels located in the IDF.

H. A minimum of one (1) WAO with one (1) voice NAM shall be provided adjacent to the elevator control panel for the elevator emergency telephone. This NAM shall consist of a surface mounted outlet box with a single port faceplate and an individually cabled fog white, T568A, Cat 5e type 8P8C module. This cable shall be terminated at the voice patch panel located in the IDF.

I. A minimum of one (1) WAO data NAM shall be provided within the building environmental control panel (BMS). This NAM shall consist of a surface mounted outlet box with a single port faceplate and an individually cabled Orange, T568A, Cat 5e type 8P8C module. This cable shall be terminated at the data patch panel located in the IDF.

J. A minimum of two (2) WAO's, each with one (1) voice and data NAM shall be provided in each conference room. These NAM's should be located in the floor and under the conference table (if planned) to avoid any tripping hazards caused by equipment patch cords. An additional WAO voice Nam for a wall-mounted telephone shall also be planned. Location of the wall-mounted WAO shall be near an exit door and shall meet ADA requirements for proper height and access. Wall-mounted telephones shall not protrude into a walkway area (i.e. aisle) if there is a possibility of the handset being knocked from its receiver by normal foot traffic.

K. Laboratories require additional WAO's to support workstations and test equipment. Wall-mounted telephones shall not be installed over laboratory countertops.

L. Large classrooms shall use a wireless network for their data access. Reference Section 9.0 Wireless Network Systems for the latest design standards for this area.

M. Dormitories require an angled faceplate to help eliminate damage to f-type couplers and patch cords.

6.3.3. NAM Conduit, Backbox and Height Requirements

A. A 4-inch by 4-inch by 2 1/4-inch electrical device box with a single gang plaster (mud) ring shall be used at each WAO installation. From **each** device box, a minimum of a 1-inch Electrical Metallic Tubing (EMT) conduit shall be installed to the cable pathway support system. **The looping of multiple NAM locations, to include floor boxes, with one EMT conduit is not allowed.** Conduit shall be sized appropriately for the fill rate of cable it is to accommodate plus future growth. Reference Section 4.0 Electrical Requirements for additional information.

B. For Fiber to the Desktop (FTTD) WAO installations, provide a 4-11/16 inch by 4-11/16 inch by 2-1/2-inch electrical device box with a 1 1/2-inch wide electrical device box extension flange added to the front of the device box inside the wall to allow for additional space (depth) for the fiber optic bend radius and a dual gang mud ring installed on the front to accommodate an 8-port faceplate if voice, data, and/or video NAM's are planned for the same location. A minimum of a 1 1/4-inch Electrical Metallic Tubing (EMT) conduit shall be installed to the cable pathway support system

C. Standard height of a WAO is 18" AFF, or as noted.

D. Standard height of a Wireless Access Point WAO is 80" AFF, or as noted.

E. Height and location of WAO's for ADA accessible wall-mounted telephones shall take into consideration the height of the telephone set and faceplate to ensure access requirements are satisfied.

Note: Payphone vendor requests the Payphone WAO's be installed at 40-inches to meet forward and side reach requirements for coin slot.

6.3.4. ADA Requirements

A. Installed wall, counter-top and weatherproof telephones, in addition to emergency call boxes and WAO's, shall meet the requirements of the Americans with Disabilities Act (ADA). This requirement is referenced in ANSI/TIA/EIA 568-B.1. <http://www.access-board.gov>

Note: Wall telephones shall not be installed above or over Laboratory countertops. A standard desktop telephone may be installed in these unique locations.

B. All campus approved wall phones (with an ADA compliant handset), emergency call boxes and towers shall be installed in accordance with ADA requirements. The following is a list of currently installed products on the UC Davis campus: Reference Figure 6-1.

1. Courtesy Phone, Wall-Mounted Telephone with ADA compliant handset, Cortelco, Part Number 2554, or equal.
2. Weatherproof Emergency Push-to-Talk Speakerphone, Surface Mount, Talk-A-Phone Products, Model ETP-SM with an ETP-400K Emergency/Assistance Phone, Yellow Enclosure, or equal.
3. Emergency/Information Tower, Talk-A-Phone Products, Model Number ETP-MT/R with an ETP-400C Telephone, or equal.
4. TTY Payphone

Figure 6-1 ADA Compliant Courtesy and Emergency Call Telephones



6.3.4. Cable Types, Colors and Lengths

A. UC Davis recognizes two types of cables for use in the horizontal segment: Unshielded Twisted Pair (UTP) and single-mode (SM) fiber optic cable.

1. UTP cable shall be 4-pair, 24 AWG, solid conductor cabling that meets ANSI/TIA/EIA 568-B.1 and B.2 cabling specifications for Category 5e cable, to include any/all current Addendums and Bulletins, and shall meet specified specifications and performance requirements. Reference Appendix A Specification 03, WAO Cabling Requirements and Table 03-1 for cable specifications and performance requirements.
2. Fiber optic cable shall be a minimum of 4-strands, single-mode,

8.3/125 μ m, tight-buffered, indoor cable. Reference Appendix A Specification 03, WAO Cabling Requirements, and Table 03-2 for cable specifications.

B. The standard cable sheath colors of horizontal copper UTP cable installed on the UC Davis campus are BLUE for Data and WHITE for Voice.

C. All conductive cable, fiber optic, radio, and television, community antenna and network-powered broadband communications systems, and associated components shall comply with the following 2001 (or the most current edition at the time of design) California Electric Code (CEC) articles:

1. Article 770 Optical Fiber Cables and Raceways
2. Article 800 Communications Circuits
3. Article 810 Radio and Television Equipment
4. Article 820 Community Antenna Television and Radio Distribution
5. Article 830 Network Powered Broadband Communications Systems

D. In addition, all fiber optic cabling shall meet or exceed OFN-FT4 (Non-plenum) and OFN-FT6 (Plenum) requirements.

E. All cabling shall be UL Listed Type CMP, OFNR, or OFNP if it is placed in air-handling plenums or risers without conduit. The cable sheath shall be marked with the UL listing.

F. Horizontal cables shall not be spliced, nor will these cables contain manufacturer splices.

G. Horizontal cables shall not be connected directly to telecommunications or network equipment. Suitable termination hardware (i.e. patch panels and 110-type punch-down blocks) and factory-manufactured patch cords shall be used to make this connection. Cross-connect jumper wire shall be used for voice and fire alarm circuits only.

H. Patch cords shall be manufactured by the same manufacturer as the data patch panels and information modules to ensure compatibility, performance, and warranty meet or exceed Category 5e requirements and specific performance requirements. Reference Appendix A Specification 04, WAO Copper and Fiber Patch Panel and Patch Cord Requirements, Table 04-1 for minimum performance requirements. Performance testing shall be conducted at the component level by a UL certified testing laboratory and include active live channel testing to ensure manufacturer and performance quality. Ortronics® Clarity^{5E} is the campus preferred and recommended manufacturer, or equal.

I. The maximum total length of horizontal cable from the IDF to WAO and including patch cords (patch panel to equipment and WAO faceplate to

workstation) shall not exceed 328 feet (100 meters). CR approved patch cord and jumper wire lengths are shown in Appendix A Specification 04, WAO Copper and Fiber Patch Panel and Patch Cord Requirements, Table 04-2.

J. Cable slack shall be provided at both ends of the cable runs to accommodate future cabling system changes.

1. The minimum amount of slack shall be 12-inches for UTP cables and 36-inches for fiber optic cables at the WAO.

2. Service loops placed during the installation of 4-pair horizontal cables were tested and determined to cause Return Loss and NEXT problems on the order of 2-3dB. When creating service loops, they shall be coiled in a Figure-Eight configuration to eliminate this effect. At UC Davis, service loops are not required for every installation; therefore, prior approval from CR shall be obtained prior to the installation of service loops. Figure-eight service loops shall not be folded over onto themselves. Support service loops using multiple j-hooks, keeping the Figure-eight configuration.

3. The length of cable slack shall be included in all length calculations to ensure the horizontal cable does not exceed 295 feet.

4. Fiber optic cable shall have a 10-foot service loop prior to terminations at the ADF/BDF/IDF location. CR shall approve the location of this service loop prior to cable installation and termination.

Note: These limits apply to all types of horizontal cables. In establishing these limits, a 33-foot allowance was made for the combined length of the manufactured patch cords used to connect equipment at the WAO and IDF locations.

6.3.5. Termination Hardware Requirements at the WAO

A. Each UTP cable shall be terminated at the WAO with a Category 5e, RJ-45 module, 8P8C, T568A, 180°-degree exits, Orange for Data, Fog White for Voice. Reference Specification 01, Table 01-1 and 01-2 for module specifications, and Specification 04, Table 04-1 for hardware performance specifications.

B. Each fiber optic cable shall be terminated at the WAO using a Small Form Factor LC style connector mounted in an LC type faceplate module. All strands shall be terminated at the WAO and IDF location for testing and verification purposes. Reference Specification 01, Table 01-1 and 01-2 for flush mount faceplate and module specifications. The LC connector module shall be from the same manufacturer as the flush mount faceplate to ensure fit, function and appearance and the LC fiber optic connector shall be from the same manufacturer as the fiber optic cable to ensure campus wide network system compatibility, performance and warranty.

C. Faceplates for the designated module shall be from the same manufacturer as the NAM and shall be in a standard Fog White color or shall match the existing décor of the room or the attached Wiremold® system, to include metal type faceplates. Reference Specification 01, WAO Faceplates, Surface Mount Boxes, Wiremold® Adapter and Modules, Table 01-1 for faceplate specifications.

6.4. Termination Hardware Requirement in the Telecommunications Space

6.4.1. The Design Process

A. The Area Distribution Frame (ADF), Building Distribution Frame (BDF) and Intermediate Distribution Frame (IDF) refer to the type of termination equipment located within the Telecommunications Space (ER/TR).

B. The term ADF refers to a cross-connect point for fiber optic cable servicing a geographical area on the UC Davis campus and outlying areas. This cross connect hardware is physically located within the Telecommunications Space (ER/TR) or Controlled Environmental Facility (CEF) and can vary in size depending upon termination space requirements (i.e. equipment racks and/or cabinets).

C. The term BDF refers to a cross-connect point for both copper and fiber optic cable serving a single or multiple buildings within an immediate area. This cross connect hardware is physically located within an ER or TR and can vary in size depending upon termination space requirements (i.e. equipment racks, cabinets, and/or backboard space).

D. The term IDF refers to a termination point for horizontal copper and fiber optic cables within a single building and/or floor. This would apply to horizontal cabling from the WAO to the 110-type cross-connect blocks for voice and 8P8C patch panels for data mounted within an equipment rack, cabinet, or mounted onto a wall. This termination hardware is located within a TR and can vary in size depending upon termination space requirements.

E. Although the ANSI/TIA/EIA 568-B.1 replaced the term IDF with the term Intermediate Cross-Connect (IC), on the UC Davis campus the terms ADF, BDF and IDF are used.

F. It is important to note that an IDF can be co-located with an ADF/BDF. Additional space, racks, electrical, and cable management are required to support these locations.

G. The locations of the ADF/BDF/IDF's shall be submitted to the project manager for inclusion in the construction drawings and they shall be annotated on the floor plan.

6.4.2. Termination Hardware Requirements in the ADF/BDF/IDF

A. Patch Panels for UTP Horizontal Data Cabling

1. The data cable in the horizontal segment shall be terminated on patch panels in the IDF. Patch panels shall be T568A 24- or 48-port, High Density, 8 port module, Category 5e patch panels. The patch panels may be mounted on a wall-mounted bracket or within a free standing welded steel equipment rack or enclosed data cabinet.

2. Reference Appendix A Specification 04, NAM copper and Fiber Patch Panel and Patch Cord Requirements, Table 04-1 for hardware performance specifications. Performance testing shall be conducted at the component level by a UL certified testing laboratory and shall include active live channel testing to ensure manufacturer and performance quality.

3. Cross-connect fields, patch panels and active equipment in the ADF/BDF/IDF shall be placed to allow cross-connections and interconnections via jumpers, patch cords and equipment cables whose lengths per channel do not exceed:

a. 7-foot per patch cord in the horizontal cross-connect.

b. 15-foot or less for patch cords used to connect to the WAO.

4. Manufactured patch cords shall be installed to meet the minimum-bending radius of 0.25 inches as specified in ANSI/TIA/EIA-568-B.1-AD-1, Sub clause Addendum 10.2.1.3.

B. Cable Management Panel for UTP Horizontal Data Cabling

1. Cable management panels shall be installed with data patch panels in all wall, rack and cabinet installations. One cable management panel is recommended for every data patch panel.

2. Ortronics® cable management panel, OR-808044855, is the preferred and recommended manufacturer, or equal.

C. Patch Panels for UTP Horizontal Voice Cabling

1. The UTP horizontal voice cabling supporting voice WAO's, fire alarm and building environmental control systems, and elevator telephones shall be terminated on a 110 cross connect system wall mount terminal block kit.

2. This same type and style of 110 cross connect system shall be used to terminate the multi-pair copper cables for Digital Loop Carrier systems located in the ADF/BDF/IDF area.

3. Reference Appendix A Specification 04, NAM Copper and Fiber Patch Panel and Patch Cord Requirements, Table 04-1 for hardware performance specifications. Performance testing shall be conducted at the component level by a UL certified testing laboratory and shall include active live channel testing to ensure manufacturer and performance quality.
4. Copper cross-connect fields in the ADF/BDF/IDF shall be placed to allow cross-connections and interconnections via jumper wire.
5. The manufacturer's color code on the front of the 110-type blocks shall be strictly adhered to during the termination of voice horizontal cables.
6. The color of the label designations strips shall follow the same color-coding of termination fields as shown in ANSI/TIA/EIA 606-A, Figure 2. Green for the entrance facility Demarcation point, White for the first level riser cable and Blue for the voice UTP cable installed in the horizontal. Reference Table 6-3 Cross Connect Field Color Codes.
7. Reference Figure 6-2 for a typical 110 cross connect system with color-coded termination fields.

D. Patch Panels for Fiber Optic Cabling

1. Fiber optic cable for outside plant and riser/backbone installations shall be terminated on Duplex 568SC Ultra PC Polish connectors at the ADF/BDF/IDF.
2. All loose-tube outside plant fiber optic cables shall have a Buffer Tube Fan Out kit installed prior to the installation of fiber connectors.
3. Fiber optic cable for horizontal installations shall be terminated on LC type connectors at the IDF and WAO locations.
4. Fiber optic termination housings shall be wall or rack mounted in welded steel equipment racks or enclosed equipment cabinets.
5. Reference Appendix A Specification 06, OSP/Riser/Backbone Fiber Optic Patch Panel/Patch Cords, for additional information on fiber optic patch panels, and Specification 09, Outside Plant and Riser Cable Labeling Requirements, for labeling requirements.
6. All rack and wall-mounted fiber optic closet connector housings shall be labeled in accordance with Appendix A Specification 09, Outside Plant and Riser Cable Labeling Requirements.
7. A 20-foot cable maintenance loop shall be left after the completion of the fiber terminations. Prior to installation, a CR representative shall approve the location of this maintenance loop.

Figure 6-2 Voice 110-type Cross-Connect System

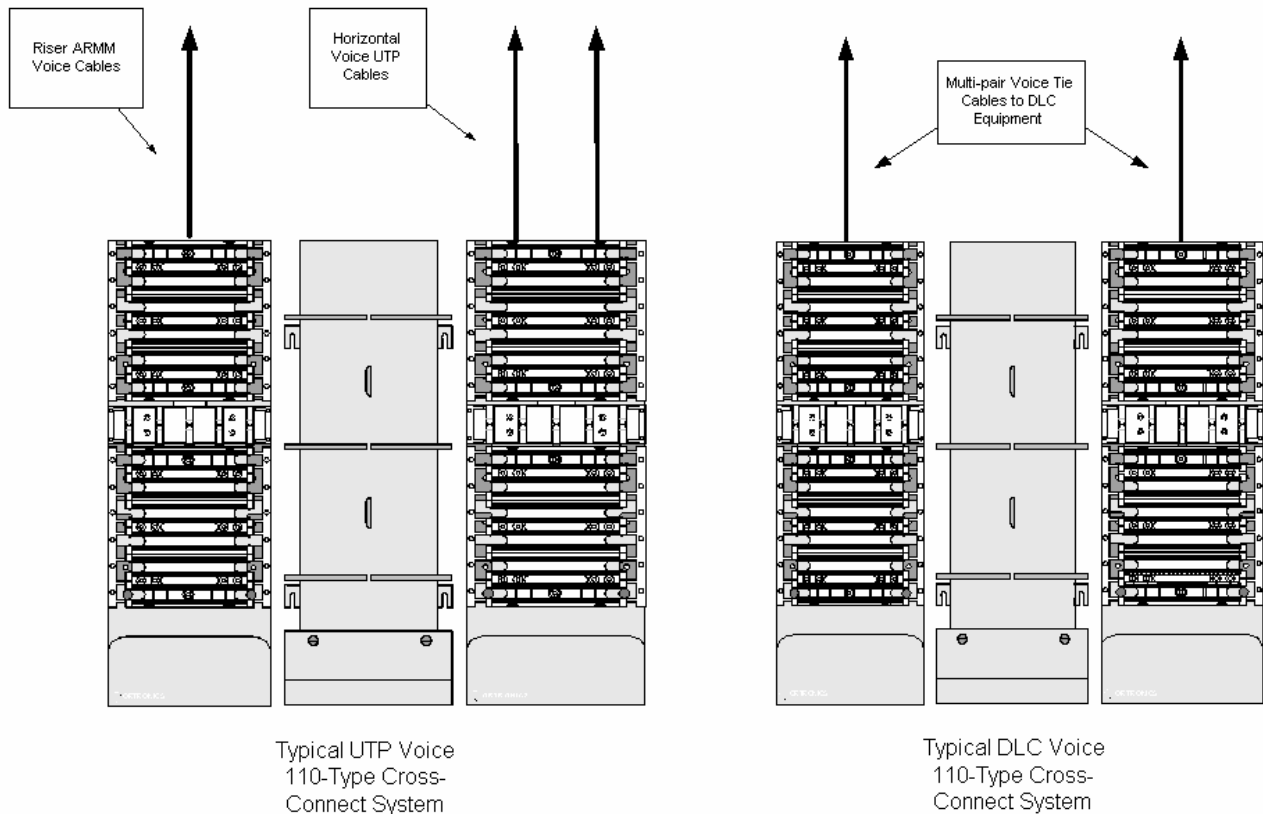

6.4.3. Support Hardware Requirements in the ADF/BDF/IDF

A. Ladder runway, equipment racks, plywood backboards, equipment cabinets, and wire management brackets for the ADF/BDF/IDF equipment shall be used to keep the cabling and equipment organized and to allow the cable plant to be installed to TIA/EIA 569-B specifications. Ladder runways shall be used to route bulk telecommunications cables within the Telecommunications Space (ER/TR, ADF/BDF/IDF).

1. Ladder runway shall be at least 12-inches wide and placed at least 7-feet, 6-inches above the finished floor to pass over the top of the equipment racks and cabinets.
2. Proper clearance from the top of the ladder rack to any HVAC ducting or other obstacles shall be provided.

3. Ladder runway shall include vertical sections secured to the floor for riser cables entering from floor sleeves, slots and conduit. Provide runway radius drops (waterfalls) for runways installed above equipment racks and cabinets.

4. All ladder runway, including splice points and T-sections, shall be bonded and grounded to the busbar located within the Telecommunications Space (ER/TR).

5. Ladder runway shall not be attached to the top of equipment racks or cabinets. Nor shall it be used as seismic bracing. All equipment racks and cabinets shall have appropriate seismic bracing as designed and approved by a California registered structural engineer.

B. Free standing equipment racks shall be UL listed, California Building Code (CBC) approved, seismic 4, one piece welded steel, 19-inches wide (17.75-inch inside dimension) by 84-inches tall, double sided with ANSI/EIA-310D spacing and 12-24 threads. Enclosed cabinets (when required) shall be ordered with the same ANSI/EIA-310D spacing and 12-24 threads to ensure consistency. Metric threaded screws and cage nuts shall not be used.

1. 3-foot working clearance shall be maintained in the front and in the rear of each equipment rack, and a 2-foot, 6-inch working clearance shall be maintained at one end of the equipment rack or multiple rack assemblies, as a minimum. The front and rear clearance shall be measured from the outermost surface of the electronic equipment and connecting hardware rather than from the equipment rack itself since some of these devices may extend beyond the equipment rack.

2. The equipment racks shall be grounded and bonded to the MTGB/TGB in the Telecommunications Spaces (ER/TR) in accordance with ANSI/J-STD-607-A. Each equipment rack and cabinet shall be grounded with an individual #6 AWG ground wire.

3. Single vertical cabling management sections shall be installed with each freestanding rack. Cable management sections shall be of the same manufacturer as the free standing rack to ensure compatibility, quality, function, and appearance.

4. Receptacles shall be located on the back-side of the active equipment racks 15-inches Above the Finished Floor (AFF). The placement of this receptacle **shall not** block or interfere with the mounting rails on either side of the rack.

C. If required, equipment and connecting hardware may be wall mounted using wood screws on rigid plywood backboard. Installed plywood backboard shall meet all requirements as listed in Section 3.0, Architectural Requirements and ANSI/TIA/EIA-569-B.

1. Horizontal and vertical wire management brackets shall be used to manage cables and jumpers. Velcro cable ties shall be used to secure cable bundles and patch cords, where required. Plastic cable ties (Tie-wraps) shall not be used.

2. The cross-connect points shall be located near the end of the riser pathways to minimize the need for cable routing in the Telecommunications Spaces (ER/TR).

3. Equipment cabinets shall be configured with jumper troughs to aid in jumper management. The fiber distribution cabinets shall be wall or rack mounted. Reference Appendix A Specification 06, OSP/Riser/Backbone Fiber Optic Patch Panel/Patch Cords.

4. Reference Appendix A Specification 07, Equipment Racks and Distribution Cabinets, for an illustration of a typical equipment rack/cabinet layout.

D. Equipment racks shall be used in all telecommunications spaces. In areas where proper security and environmental conditions cannot be met or maintained, then equipment cabinets shall be considered.

E. ADF's (Area Distribution Frames), in some cases, may require cabinets. Contact CR for the allocation of space required for each type of termination within these cabinets. See Appendix A Specification 07, Equipment Racks and Distribution Cabinets, for details on these cabinets.

F. Manufactured patch cords shall be installed to meet the minimum-bending radius of 0.25 inches as specified in ANSI/TIA/EIA-568-B.1-AD-1, Sub clause Addendum 10.2.1.3.

6.4.4. Drawings for Construction/Project Managers

A. The following steps shall be taken once the size, location, design requirements, termination hardware and support structures for the cabling have been determined for the ADF/BDF/IDF:

1. Notify the construction/project manager of the ADF/BDF/IDF's locations for inclusion in the construction drawings for the University to review for appropriate schematic, design or construction documents.

2. Annotate on the floor plan the ADF/BDF/IDF's locations.

3. Prepare sketches of each ADF/BDF/IDF. The following information shall be included:

- a. Overall room dimensions.

- b. Electrical service convenience receptacle locations.

- c. 20 ampere electrical service locations.
- d. Main Telecommunications Grounding Busbar (MTGB) and Telecommunications Grounding Busbar (TGB) location.
- e. Door and door openings - size, direction, location, type, fire rating.
- f. Location and size of sleeves and/or slots, entrance conduits, and cable tray entering room - include details of each.
- g. Location and height of lighting (ensure that ladder racking and racks shall not block or interfere with the lighting).
- h. Overhead cable ladder racking system within the room.
- i. Equipment racks, open or enclosed electronic cabinets and wall mounted cross connect fields.
- j. ADF/BDF/IDF number and room number.
- k. See Section 4.0 Electrical Requirements, Figure 4-1 for an example of a typical IDF layout.

B. Provide sketches³ to the construction/project manager for dissemination to the other engineering disciplines involved in the design project. Provide AutoCAD version 14 or later in electronic format and on D size drawing.

6.5. Assigning the NAM numbers

A. The NAM matrices are used by Communications Resources for the assignment of services to departments, and other related purposes. They are crucial to the implementation of new service to the customer. Reference Specification 02, NAM Numbering, Matrix and Labeling Requirements, for addition information.

B. The consultant shall obtain NAM numbers from the UC Davis project line assigner. Contact CR for information.

C. After NAM numbers have been assigned to the floor plans, the consultant shall complete the NAM matrices. Refer to Specification 02, NAM Numbering, Matrix and Labeling Requirements, for information on NAM's and NAM matrices. NAM matrices are to be completed at the beginning of the Construction Document (CD) phase. A hardcopy of NAM matrices shall be provided to the UC Davis A&E project manager and CR. An MS-Excel 2000 spreadsheet in the format shown in Specification 02 shall be provided to CR.

³ Reference: UC Davis Campus Standards & Design Guide, Administrative Requirements, May 2003

D. The consultant shall ensure that specifications are placed in the contract documents that shall inform the cabling contractor on the use and maintenance of the NAM matrices for the project.

6.6. Cross Connecting Voice NAM's

A. The project consultant shall ensure that the CR project line assigner provides a voice NAM matrix, identifying all cross connections from the WAO to the IDF. The contractor is responsible for completing all voice cross-connect terminations at the IDF. CR shall complete all voice cross-connect terminations at the ADF and BDF.

B. The voice, data, MATV and FTTH NAM Matrix's shall be provided to CR as part of the record drawing documentation and shall be provided prior to final inspection of the cabling work.

C. Reference Appendix A Specification 02, NAM Numbering, Matrix and Labeling Requirements, for additional information.

6.7. Structures to Support the Structure (Horizontal) Cabling

A. Special attention is required when selecting and designing the type and layout of structures to support the horizontal cabling. The design shall accommodate cabling changes with minimum disruptions to building occupants.

1. Determine the size and type of cable tray (wire basket is preferred).
2. Determine cable tray routes.
3. The installation of the J-hooks should be in the same project section as the installation of the communications cable.
4. The electrical drawings shall show all pathway information depicting complete installation details. If this information cannot be incorporated into the electrical drawings, a separate set of telecommunications drawings (T-Series) with sufficient detail shall be prepared.
5. Ensure coordination with the other design disciplines (architectural, electrical, mechanical) for required access space in the ceiling areas and that the installed cable trays and J-hooks are not blocked by HVAC ducting, electrical conduits and piping (water, waste, gas, etc).

Note: UC Davis requires that the space above the ceiling grid be used, whenever possible, to route the horizontal cabling.

B. Listed below are the steps needed to complete this phase of the design process:

1. Annotate, on the floor plan, the locations and types of WAO's.

2. Annotate, on the floor plan, the locations of the equipment racks/cabinets located within the Telecommunications Space (ER/TR) for the ADF/BDF/IDF hardware.

3. Verify that the distance from each WAO to the IDF does not exceed 295 feet. This distance shall include the planned cable path and any vertical transitions, cable slack, and service loops required.

Note: If there are horizontal cable lengths that will exceed the 295-foot distance limitation, then the IDF shall be relocated to a more centralized location or an additional IDF shall be added.

4. Annotate the route of the conduit and the cable tray on the floor plan.

5. Cable trays and conduit entering the Telecommunications Spaces (ER/TR) shall be labeled per TIA/EIA 606-A. Reference Section 4.0 Electrical Requirements.

Note: The preferred method of routing the horizontal cabling is to install conduit from the WAO to a cable tray placed along natural building corridors. The cable tray shall channel the cable back to the IDF. Reference Section 4 for conduit design considerations.

6. A 1-inch EMT conduit shall be used from the WAO to the cable tray. A larger EMT conduit shall be used if the bulk of the cables to be installed comes close to or exceeds the recommended 40% fill ratio plus future growth. Reference Section 4.0, Electrical Requirements, for details on horizontal conduit capacity.

7. A minimum 1¼-inch or larger EMT conduit shall be used for all FTTD WAO's to the cable tray.

8. The looping of multiple WAO's with one conduit is not permitted.

9. The following additional specifications shall also apply to the installation of conduit.

a. Flexible EMT conduit is restricted to a 20-foot length, if required, in accordance with TIA/EIA 569-B.

b. All conduits shall be appropriately firestopped in accordance with TIA/EIA 569-B, Annex A and any/all local fire codes as applicable.

c. All firestopping devices and materials shall be labeled in accordance with TIA/EIA 606-A. Reference Section 4.0, Electrical Requirements, Figure 4-2 and 4-3.

d. Pull string shall be installed in all conduits with a minimum test rating of 200 pounds.

e. The ends of conduits shall be reamed and bushed to eliminate sharp edges that can damage cables during installation or service.

10. Identify firewalls or fire rated barriers that may be breached during cable installation.

11. Conduit shall extend through the fire rated barrier when a fire rated barrier exists between the WAO and cable tray.

Note: All horizontal pathways that penetrate fire rated barriers shall be firestopped in accordance with TIA/EIA 569-B, Annex A and local fire code. Reference Section 4.0, Electrical Requirements, Figure 4-2.

12. Identify hard ceiling or ceilings with restricted access that shall be traversed during cable installation. The following requirements shall apply:

a. A minimum of three (3) trade size 4 EMT conduits shall be used in these areas. Reference Section 4.0, Electrical Requirements, Figure 4-4.

b. Conduits shall be of a size that shall ensure the 40% fill ratio is not exceeded and sized for future growth.

c. The ends of the conduit shall be bonded and grounded to the cable tray system which is grounded and bonded to the Telecommunications Grounding Busbar (TGB). Reference Section 4.0, Electrical Requirements, Figure 4-4.

d. Each end of the conduit shall have a plastic protective bushing installed.

Note: Per the NEC, metallic conduit that contains a ground wire and is a total length of 3 feet or more shall be grounded at each end.

13. Surface molding shall be used to route cables from the WAO to the interstitial space in areas with limited ceiling access. Wiremold® surface raceway is the campus preferred and recommended manufacturer to ensure compatibility with the Ortronics® faceplates and TracJack® modules. If substitutions are requested by the consultant/contractor, then documentation and demonstration of equivalency shall be provided.

14. Identify WAO's that will be located on walls that are not made of sheet rock construction, such as plaster walls, concrete block walls, exterior walls and insulated walls. Written approval shall be obtained from Communications Resources, Engineering and Construction Management, to use surface mounted WAO's if these walls cannot be fished. Wiremold® surface raceway is the campus preferred and recommended manufacturer to ensure compatibility with the Ortronics® faceplates and TracJack® modules. If substitutions are requested by the consultant/contractor, then documentation and demonstration of equivalency shall be provided.

15. Identify the location of modular furniture that will be cabled for voice and data. Modular furniture shall be cabled from furred columns or wire whips from abutting walls, power poles or under-floor systems.

Note: Interior and Exterior walls, when furred and covered with sheet rock, may not provide the necessary clearance between the sheet rock and the backing material (concrete block) for standard WAO's.

Note: The use of power poles shall be minimized.

16. Minimum cable bend radii and conduit capacity shall be considered when installing cable to a module furniture system.

17. The minimum bend radius for a 4-pair UTP cable with no load is 4 times the outside diameter or 1-inch. The minimum bend radius for horizontal fiber optic cable is 2-inches.

18. Reference Section 4.0, Electrical Requirements, for details on conduit capacity.

19. The maximum pulling tension of 4-pair UTP cable shall be 25 lbf and the maximum tensile load for horizontal fiber optic cable is 148 lbf.

20. Annotate on the floor plan drawing(s) the cable path that will be supported with J-hooks or adjustable cable supports (Hanger Bags). The type and size of J-hook or hanger bag shall conform to the manufacturer specification for size and number of cables and the environment for which they are to be installed. This specification shall not be exceeded.

21. J-hooks and hanger bags shall be spaced a maximum of 48-inches to 60-inches to support the cable as referenced in TIA/EIA 569-B and shall be annotated on the construction drawings.

22. Velcro cable ties shall be used to secure cable bundles and patch cords, where required, in the ADF/BDF/IDF. Plastic Tie-wraps shall **not** be used in either the Telecommunications Space or in the accessible ceiling areas.

6.8 Testing Requirements for Copper and Fiber Optic Horizontal Cables

6.8.1. General

A. Test and document each horizontal cable segment separately.

B. Test each end-to-end cable link.

6.8.2. UTP Horizontal Voice and Data Cable Testing

A. UC Davis requires that all UTP horizontal station cables be Permanent Link tested with a Level IIE, Level III or later tester for full compliance with TIA/EIA 568-B.1 and B.2, (to include all current addendums) Category 5e specifications, regardless of intended use.

B. Test results shall be provided for all conductors of each cable and shall meet Table 6-1 parameters.

C. Provide tester-generated documentation in hard copy (paper copy) and soft copy (CD electronic copy) of all test results:

1. Test results shall be organized by NAM# and closet in an orderly fashion.
2. CD electronic copy shall have the latest version of software burned on it for viewing test results and a copy of the transmittal letter explaining any issues regarding the test results (skipped #'s, cause of failures, etc.).
3. CD shall have a computer generated label with:
 - a. Contractors Name
 - b. Date
 - c. UC Davis Bldg name, CAAN #, and CR Project number
 - d. Contents (Fiber/copper Test Results, etc.)

Table 6-1 Permanent Link Testing

Parameter	Category 5e
Specified Frequency Range	1-100 MHz
Pair to Pair NEXT	32.3 dB
Power Sum NEXT	29.3 dB
Insertion Loss	21.0 dB
Pair to Pair ELFEXT	18.6 dB
Power Sum ELFEXT	15.6 dB
Return Loss	12.0 dB
Propagation Delay	498ns @ 10MHz
Delay Skew	44ns
Wire Map	T568A
Length	≤295 feet

6.8.4. FTTD Horizontal Cable Testing:

A. UC Davis requires that all horizontal single-mode Fiber to the Desktop (FTTD) cables be tested for full compliance with TIA/EIA 568-B.1 and B.3 (to include all current addendums), regardless of intended use.

B. Field-testing instruments for single-mode fiber optic cabling shall meet the requirements of ANSI/TIA/EIA-526-7. Testing Method A and B shall be accomplished. Reference TIA/EIA-568-B.3 for additional test requirements.

C. Fiber optic testing procedures:

1. Link attenuation (Power Meter):

a. All horizontal single-mode fiber optic cables shall be tested for link attenuation (i.e. power insertion loss, power meter test) as referenced in TIA/EIA-568-B.1, Section 11.3. See Table 6-2 for proper fiber testing measures. All strands shall be tested in a bi-directional method with a Power Source and Meter.

b. All fiber optic cables, to include connectors, shall be tested in-line between two reference cables. One cable shall be attached to the light source and the other to the power meter

to measure the dB loss from both connectors, as well as, any dB loss associated with the cable between the connectors.

c. TIA/EIA 568-B.1 and TIA/EIA 526-7 outlines the steps required to test single-mode fiber optic cable. All fiber optic cables shall be tested from each end at both wavelengths 1310nm and 1550nm.

Note: Because of the relatively short cable lengths within the horizontal segment (less than 295-feet), the main loss will be connector loss.

d. Ensure that all connectors (on both sides of the mating sleeve) are clean prior to testing. **Do not** use canned air to clean the connectors or mating sleeves. Some can air products can leave a fluid buildup and/or create a static charge.

e. Test the horizontal segment from distribution housing in the Intermediate Distribution Frame (IDF) to the WAO. Once all fiber strands are tested, reverse this procedure and retest. The light source should not be disturbed once the testing begins.

f. Provide tester-generated documentation in hard copy (paper copy) and soft copy (CD electronic copy) of all test results.

1. Test results shall be organized by NAM# and closet in an orderly fashion.

2. CD electronic copy shall have the latest version of software burned on it for viewing test results and a copy of the transmittal letter explaining any issues regarding the test results (skipped #'s, cause of failures, etc.).

3. CD shall have a computer generated label with:

a. Contractors Name

b. Date

c. UC Davis Bldg name and number

d. Contents (Fiber/copper Test Results, etc.)

2. Optical Time Domain Reflectometer (OTDR)

a. Horizontal cables shall be tested for dB loss and end-to-end total installed distance with an OTDR. Each trace shall indicate the cable length and dB loss.

b. All OTDR traces shall be tested bi-directional, **from** and **through** the first connector pair (test location) to the WAO and from the WAO to the termination housing, at both wave lengths.

c. All OTDR traces shall be accomplished using a manufactured and terminated corning MM/SM, as appropriate, glass launch cable. Make sure you are using the correct fiber type and core size. Launch cable can not be made in the field, must be factory made.

d. All OTDR traces shall be accomplished using the Medium Smooth setting.

e. All OTDR traces shall indicate test readings taken in feet.

f. All OTDR test traces shall indicate a 2-Point dB loss between the A and B test trace cursors (showing test location and end fiber optic patch panels).

g. Test traces shall be provided on both paper copy **and** CD (electronic copy) that is readable by Corning Cable Systems, GN Net Test or Fluke LinkWare software.

D. The installing contactor shall perform fiber optic testing on all installed fiber optic cabling. All documented test results shall be provided to the Communications Resources (CR) representative for review and approval. The contractor shall submit these forms with all required information no later than five days after the cables are tested.

E. The contractor shall provide calibration certifications for testing equipment to be used. The contractor shall submit these certificates to CR, with all required information, prior to commencement of testing.

Table 6-2 Maximum Loss Measurements

Maximum Loss Measurements for Installed Fiber Optic Cables	
Mated Connector Loss:	0.5 dB per mated pair
Connector Loss:	0.5 dB per connector
Splice Loss: Fusion Multimode	0.15 dB
Fusion Single-mode	0.06 dB
Mechanical	0.3 dB
Fiber loss: Multimode	3.5 dB/km @ 850 nm 1.0 dB/km @ 1300 nm
Fiber loss: Single-mode	0.4 dB/km @ 1310 nm (Outside Plant Cable) 0.3 dB/km @ 1550 nm (Outside Plant Cable) 1.0 dB/km @ 1310 nm (Inside Plant Cable) 0.75 dB/km @ 1550 nm (Inside Plant Cable)

6.9. Riser Segment

6.9.1. The Design Process

A. The riser segment consists of the riser cable and the supporting infrastructure within a building or cluster of buildings that connects the Telecommunications Spaces (ADF/BDF/IDF's within the ER/TR's).

B. The riser termination segment shall be designed as illustrated in Figure 6-3.

C. Table 6-3 lists the following color codes for cross connect fields. Table 6-3 shall be used to identify horizontal and riser cables in accordance with TIA/EIA 606-A.

Table 6-3 Cross Connect Field Color Codes

TERMINATION TYPE	COLOR	COMMENTS
Demarcation point	Orange	Central office connection
Network connections	Green	User side of Central Office connection
Common equipment PBX, Host, LANs	Purple	Connections to PBX, mainframe computer, LAN, multiplexer
First level backbone	White	Terminations of building backbone cable connecting MC to IC's
Second level backbone	Gray	Terminations of building backbone cable connecting IC to HC's
Horizontal	Blue	Terminations of horizontal cable in TS
Campus backbone	Brown	Termination of backbone cable between buildings
Miscellaneous	Yellow	Alarms, security or energy management
Key systems	Red	Connections to key telephone systems

Figure 6-3 Riser Segment

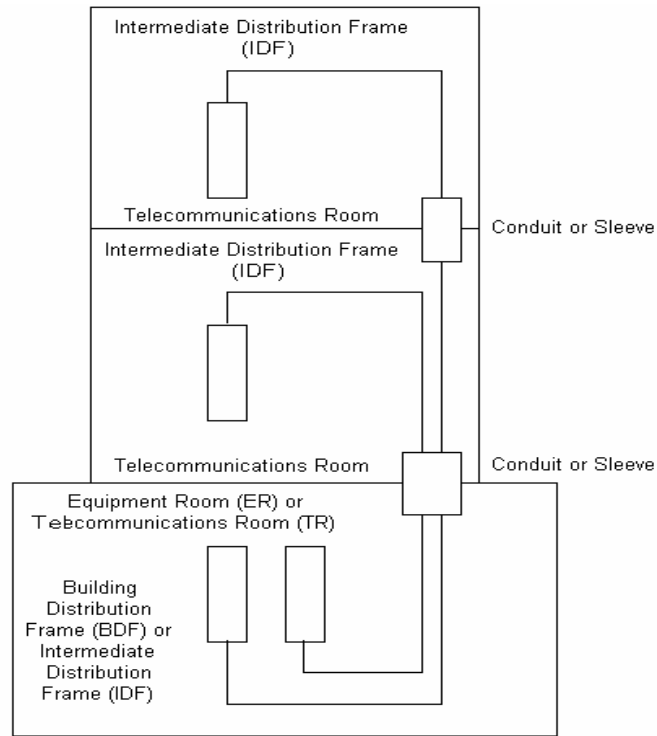

6.9.2. The Size, Type and Termination of Copper Riser Cable

A. The size of the riser cable is a function of the number of WAO's supported by the IDF.

1. The minimum number of copper riser cable pairs required for each (2) voice NAM's = 2 pairs, three (3) or more voice NAM's = 2.5 pairs.

2. Riser cables **shall** be sized to the next larger, even pair size (i.e. 100, 200, 300, etc).

B. The type of riser cable shall meet the following requirements:

1. UL 444 and 1666, ANSI/TIA/EIA 568-B.2, FCC Part 68, Telecordia GR-111, Category 3, listed as CMR.

2. The type of riser cable shall be ARMM. This type of cable can be placed in vertical shafts without the use of conduit. Filled-core outside plant cable shall not be used for interior backbone cable.

3. The riser cable is labeled based on a cable number assigned by Communications Resources Project Line Assigner. The cable pair count shall also be included in the label.

4. ARMM riser cables **shall be** grounded and bonded in accordance with ANSI-J-STD-607-A requirements, as applicable.

5. Plenum rated, multi-pair copper cables shall be installed in horizontal (cable tray) installations between the BDF and IDF, where required.

C. Reference Appendix A, Specification 04, WAO Copper and Fiber Patch Panel and Patch Cord Requirements, for riser cable termination hardware and cross-connect wire.

6.9.3. The Size, Type and Termination of Fiber Optic Riser Cable

A. The size of the riser fiber optic cable is a function of the number of data NAM's served by the IDF and the type of IDF.

1. The recommended minimum number of fiber strands for each type of IDF is shown in Table 6-4.

2. Each IDF fiber cable shall be comprised of single-mode fiber strands. Actual fiber type and strand counts shall be based upon the requirements of each project. Contact CR for fiber strand information.

Table 6-4 Recommended Size of Riser Fiber Optic Cable

Number of Data NAM's	Number of Fiber Strands Required
24 data NAM's or less	12 strands
25 to 48 data NAM's	24 strands
49 to 96 data NAM's	48 strands
97 data NAM's and up	72 strands

B. The type of riser cable shall meet the following requirements:

1. Conform to CEC Article 770 and comply with the State of California fire codes as interpreted by the Campus Fire Marshal's office.

2. The type of riser cable shall be UL listed OFNR rated. This type of cable can be placed in vertical shafts without the use of conduit. Filled-core Outside Plant cable shall not be used for interior backbone cable.

3. The riser cable is labeled based on a cable number assigned by Communications Resources. The fiber strand numbers shall also be included in the label.

4. The cable shall be of the same manufacturer as the fiber optic termination equipment to ensure fit, function, system compatibility, performance and warranty. The campus recommended and preferred cable is the Corning Cable Systems® Infinicor™ MIC® type cable.

C. Reference Appendix A, Specification 04, NAM Copper and Fiber Patch Panel and Patch Cord Requirements, for termination hardware and patch cords.

D. Table 6-5 shows the conduit fill ratio requirements for riser cables.

Table 6-5 Maximum Fill Requirements for Riser Cable

*Internal diameters are taken from the manufacturing standard for electric metallic tubing and rigid metal conduit.

Conduit		Area of Conduit		
Trade Size (Inches)	Internal Diameter* (Inches)	Maximum Recommended Fill		
		1 Cable 53% Fill (in ²)	2 Cables 31% Fill (in ²)	3 Cables 40% Fill (in ²)
1	1.05	0.46	0.27	0.35
1¼	1.38	0.80	0.47	0.60
1½	1.61	1.09	0.64	0.82
2	2.07	1.80	1.05	1.36
2½	2.47	2.56	1.49	1.93
3	3.07	3.95	2.31	2.98
3½	3.55	5.28	3.09	3.98
4	4.03	6.80	3.98	5.13

6.10. Testing Requirements for Copper and Fiber Optic Riser Cables

6.10.1. General

- A. Test and report each intermediate cable segment separately.
- B. All test results shall be documented as listed below.

6.10.2 Copper Riser Cable Testing Requirements

- A. Riser copper cables shall be tested upon completion of installation.

B. All pairs shall be tested and documented on the UC Davis Test Documentation sheet for Copper OSP and Riser cables. Reference Figure 6-4.

C. The specifications shall require the contractor to perform tests on all voice riser cables. The tests shall be performed end-to-end from each termination block on each pair. This end-to-end test shall include the following:

1. Continuity
2. Reversals
3. Shorts
4. Opens (Unbalanced)
5. Splits
6. Transpositions
7. Grounds
8. Overall loop resistance measured in Ohms
9. Total cable length measured in Feet

Figure 6-4 UC Davis Test Documentation Sheet Cooper OSP/Riser Cable (Sample)

UC Davis Test Documentation									
Copper OSP and Riser Cable Test Requirements									
Cable Number:									
Cable Pair Count:									
CAAN/Room Number Tested From:									
CAAN/Room Number Tested To:									
Pair Number	Continuity	Reversal	Short	Open	Loop Resistance	Split	Transposition	Ground	Cross
1									
2									
3									
4									
5									
6									

6.10.3 Fiber Riser Cable Testing Requirements

A. Fiber optic riser cables shall be tested upon completion of installation.

B. All fiber optic riser cables shall be tested in accordance with the procedures listed in paragraph 6.8.4, FTTH Horizontal Fiber Optic Testing.

C. All strands shall be tested bi-directionally at both wavelengths and documented.

D. Field-testing instruments for multimode fiber optic cabling, if installed, shall meet the requirements of ANSI/TIA/EIA-526-14-A. The light source shall meet the launch requirements of ANSI/TIA/EIA-455-50B, Method A. Reference TIA/EIA-568-B.3 for additional information. Per ANSI/TIA/EIA 526-14A, Annex B, Test Method B shall be accomplished.

E. Field-testing instruments for single-mode fiber optic cabling shall meet the requirements of ANSI/TIA/EIA-526-7. Testing Method A and B shall be accomplished. Reference TIA/EIA-568-B.3 for additional information.

F. The riser fiber optic cable shall be tested for link attenuation as referenced in TIA/EIA-568-B.1, Section 11.3. All strands shall be tested from each terminated location, using an OTDR and power meter. CR **will not** accept a two-strand loop test.

G. The riser cable, to include connectors, shall be tested in-line between two reference cables. One cable shall be attached to the light source and the other to the power meter to measure the dB loss through both paired connectors, as well as, any dB loss associated with the cable between the connectors.

H. All riser cables (multimode and single-mode) shall be tested at both wavelengths: 850 and 1300nm for multimode and 1310 and 1550nm for single-mode.

I. The power meter light source shall be allowed to stabilize for approximately 5 minutes before testing begins to ensure an accurate test is accomplished. The light source should not be disturbed once the testing begins.

J. Ensure that all connectors (on both sides of the mating sleeve) are clean prior to testing. **Do not** use canned air to clean the connectors or mating sleeves. Some can air products can leave a fluid buildup and/or create a static charge.

K. Installed cables that **do not** meet and pass the calculated lost budget, as determined by the consultant/contractor and approved by CR, shall be reterminated and retested by the contractor at no cost to the university.

L. Installed cables that continue to fail minimum test standards shall be replaced at no cost to the university campus.

M. All cable test results shall be documented on the UC Davis Test Documentation sheet available for downloading from the CR Project web page (www.cr.ucdavis.edu). Reference Figure 6-5.

Figure 6-5 UC Davis Test Documentation Sheet Fiber Optic FTTD/OSP/Riser Cable (Sample)

UC Davis Test Documentation											
Optical Attenuation Link Results (power meter and source results)											
Results based on Dual Wavelength, One Direction Testing											
Project Name:						Testing Contractor:					
Project Number:						Name of Tester:					
Date:						Cable Description:					
Connector Type:											
Start (CAAN Number)	End (CANN Number)	Panel Number	Fiber Distance (meters)	Number of Connector Pairs	Number of Splices	SM Optical Budget (1310nm)	SM Optical Budget (1550nm)	MM Optical Budget (850nm)	MM Optical Budget (1300nm)	SM Results	MM Results
1											
2											
3											
4											
5											
6											

7.0 Outside Cable Plant

7.1 General

7.1.1. The Design Process

A. The campus segment consists of Outside Plant (OSP) cables and structures needed to interconnect the Central Office (CO), Network Operations Center (NOC) and ADF's, BDF's and IDF's located within Equipment and Telecommunications Rooms (ER/TR).

B. The supporting structure includes underground (in conduit) cables, direct-buried cables, conduit, maintenance holes (MH), hand holes (HH), aerial cables, pole lines, pedestals and outside terminals. The campus segment shall be designed and installed to NESC and ANSI/EIA/TIA-758-A Standards for Outside Plant Telecommunications Construction.

C. This section describes the policies and procedures for the following design activities:

1. Identifying cable routes from building to building.
2. Selecting cable distribution methods.
3. Determining the aerial, underground, and direct-buried cable requirements.
4. Identifying the types of cable used in the campus segment.
5. Determining MH and HH requirements.
6. Determining electrical protection and bonding/grounding requirements.
7. Provide outside plant and riser cable labeling requirements.

7.1.2. Cable Routes

The following steps shall be used to identify the cable routes between new buildings and major building renovations.

- A. Obtain a photocopy of the campus layout map.
- B. Determine where the cable entrance point is for each building.
- C. Sketch the cable route from the starting point to the termination point in the buildings to be served on the campus layout map.
- D. Note any obstacles, existing cable facilities, or other underground utilities on the campus layout map.

E. Note if right-of-way permits or easements are required.

F. Review proposed cable route to determine if conditions exist that require environmental impact applications. Identify sources of future cable maintenance problems.

7.1.3. Cable Distribution Methods

A. The Engineering and Construction Management (ECM), Communications Resources (CR) shall be contacted to determine the best cable distribution method along the proposed cable route. The method may be one or a combination of underground, direct-buried, directional boring, or aerial.

B. An underground cable system consists of cables placed in buried conduits connected to maintenance holes (MH) and hand holes (HH). Conduits are also installed from the building entrance location to poles, pedestals, MH's and HH's. Multiple and/or large splices shall be located in maintenance holes only.

C. A direct-buried cable system consists of cables and associated splices directly placed in the earth. The trench runs from the building entrance location to a pole, pedestal, MH or HH. This method is used **only** in cases where underground or aerial installations cannot be accomplished. CR must approve all direct-buried installations **prior** to their design.

D. An aerial cable system consists of cables installed on aerial support structures such as poles, sides of buildings, and other above ground structures.

Note: An underground cable system shall be used if a conduit route is available between buildings.

7.2. Underground and Direct-buried Cable Requirements

A. The California Public Utilities Commission (CPUC) regulates underground and direct buried cable placement specifications. All underground conduit and direct-buried construction at UC Davis shall conform to CPUC's General Order (G.O.) Number 128, Section IV.

B. Underground and direct-buried cable projects shall be designed from engineering drawings approved by Communications Resources. These drawings⁴ shall include the following information:

1. Details of typical trench cross sections showing cable and duct locations in the trench, clearances from final grade, backfill materials and depths, pavement cutting information, and compacting requirements for both paved and unpaved areas.

⁴ Reference: UC Davis Campus Standards & Design Guide, Administrative Requirements, May 2003.

2. Construction notes applicable to the work being performed.
 3. A scaled drawing showing location ties to existing structures, cable, conduit, maintenance and hand holes and any conflicting substructures.
 4. Profile drawings of congested areas, where vertical and horizontal separation from other utilities is critical, shall be accomplished for use during cutting and placing operations. These drawings shall also include any additional areas as requested by UC Davis.
 4. A legend explaining symbols of all relevant structures and work operations.
 5. Cable types, fiber optic strand and copper pair counts, and directions of feed.
 6. Conduit types, dimensions, wall to wall, and wall to building measurements when used with MH, HH, Pedestals and ER/TR's.
 7. MH/HH drawings showing cable racking information, applicable cable pair and fiber strand counts, conduit assignments, splicing details, north point arrows, and street names. Drawings shall be consistent with this standard.
- C. All cables entering a building shall conform to the bonding and grounding requirements listed in the CEC, Articles 250, 770, 800 and TIA/EIA-J-STD-607-A.
- D. Warning tape containing metallic tracings shall be placed a minimum of 18-inches above the underground conduit/duct structure and direct-buried cable to minimize any chance of accidental damage. The American Public Works Association has adopted the color orange for the telecommunications cables. Both ends of the metallic warning tape shall be accessible after installation. Communications Resources shall approve this accessibility prior to the completion of conduit/duct and cable placement.
- E. Refer to Section 2 for details on underground conduit requirements and conduit sizing.
- F. The minimum depth of a trench shall provide 24 inches of cover from the top of the conduit/cable to final grade. If the minimum cover cannot be obtained, then the conduits shall be concrete encased to prevent accidental damage.
- G. Local underground utilities shall be contacted (48 hours prior to excavation or in accordance with statutes regulation utilities) and an Underground Service Alert (USA) call number receipt (ticket) shall be present and on-site during any construction. All utilities, such as power, gas and water, drainage, sewer, communications and outdoor lighting shall be located and marked prior to any excavation work.
- H. Table 2-2 in Section 2.0, Site Construction, shows the vertical or horizontal separations that shall be maintained between telecommunications facilities and other facilities sharing a common trench.

I. See Figures 7-1 and 7-2 for typical trench cross-sections.

L. Install a 12-14 AWG copper wire in any unused conduit structures not programmed for immediate fiber or copper cable installation and/or where all dielectric fiber optic cable is installed, for the purpose of tracing the conduit/cable route.

Figure 7-1 Trench cross-section for paved areas

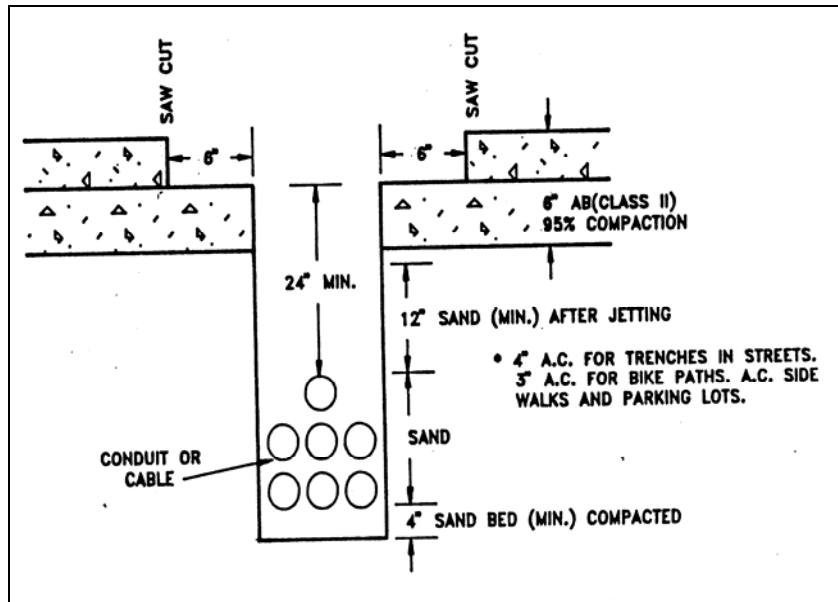
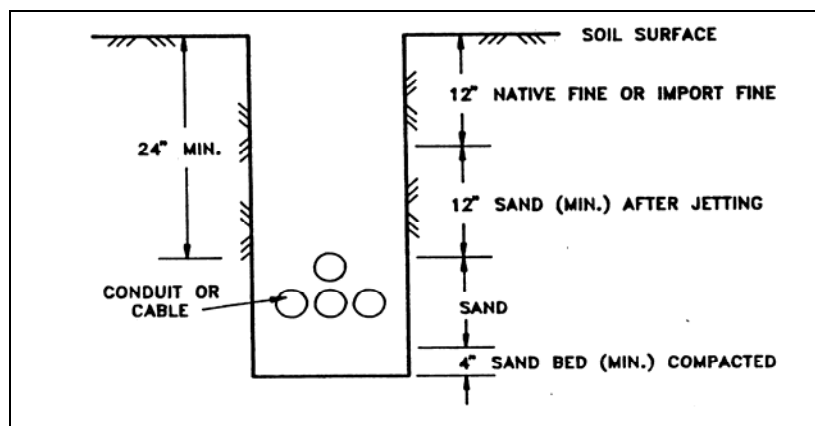

Figure 7-2 Trench cross-section for non-paved areas.



7.3. Cable Types

UC Davis recognizes two types of cable for outside plant use in the campus segment: copper twisted pair telephone and fiber optic cable.

7.3.1. Outside Plant Copper cable:

1. Filled core (waterproofing compound) cable shall be used for underground and direct-buried cable installations. Filled cable preserves the integrity of the cable by providing physical protection against moisture penetration and seepage.
2. Aerial cable installations require an air-core type of cable.
3. Direct-buried cable installations require an armored sheath type of cable to resist rodent and penetration type damage.
4. All outside plant cable shall be Plastic Insulated Conductors (PIC) and the cable jacket shall be marked with the cable length, cable code, date and manufacturer.
5. The following standard designations for copper exchange cable have been assigned by the Rural Utilities Services (RUS):
 - a. PE-39 refers to filled cable with solid polyolefin insulation and is suitable for conduit and direct-buried applications. Cable shall meet ANSI ICEA 7CFR-1755-039 and 390 specifications.
 - b. PE-89 refers to filled cable with formed polyolefin insulation and is suitable for conduit and direct-buried applications. Cable shall meet ANSI ICEA 7CFR-1755-089 and 890 specifications.
6. Minimum bend radius shall be maintained during and after the installation phase. The minimum bend radius during installation is 10 times the outside diameter of the cable and 8 times the outside diameter after installation.

7.3.2. Outside Plant Fiber Optic cable:

1. Loose Tube dry cable with waterblocking technology cable by use of a water-swellable tape shall be used for underground installations. A loose tube traditional filled core flooding compound cable shall be used for direct-buried fiber optic cable installations. Waterblocking cable preserves the integrity of the cable by providing physical protection against moisture penetration and seepage. Loose tube fiber optic cable is the preferred and recommended cable for outside plant applications at UC Davis.
2. Direct-buried fiber optic cable requires an armored sheath to resist rodent and penetration type damage.
3. Reference Appendix A Specification 05, Indoor/Outside Plant Fiber Optic Cable Requirements, for cable specifications.

4. Minimum bend radius shall be maintained during and after the installation phase. The minimum bend radius during installation is 15 times the outside diameter of the cable and 10 times the outside diameter after installation.
5. The recommended minimum number of fiber strands for each type of TS is shown in Table 7-1.

Table 7-1 Recommended Size of OSP Fiber Optic Cable

Type of Telecommunications Space	Number of Fiber Strands Required
ADF	144 strands
BDF	72 strands
IDF	See Table 6-4 for strand count

7.4. Aerial Cable Requirements

A. Overhead line construction (aerial electric supply and communications systems) specifications are regulated by the California Public Utilities Commission (CPUC), and shall conform to General Order (G.O.) Number 95.

B. Aerial cable projects shall be designed from engineering drawings approved by Communications Resources. These drawings⁵ shall include the following information:

1. Pole data, including pole class, length, heights of attachments, cross arms and pole steps.
2. Cable support strand sizes, down guys, anchors and lead-height ratios.
3. Span lengths, including appropriate information for slack span constructions, crossovers, pull-offs or any other special proposals.
4. Grounding and bonding instructions.
5. Construction notes that are applicable to the work being performed.
6. A legend explaining symbols of all relevant structures.
7. Cable counts, types, and directions of feed.
8. Terminal counts and splicing details.

C. Aerial entrances shall be limited to small buildings requiring 100 cable pairs or less for service provider connections.

⁵ Reference: UC Davis Campus Standards & Design Guide, Part, Administrative Requirements, May 2003.

D. The following steps shall be taken to design an aerial plant:

1. Select permanent locations for pole lines while considering:
 - a. Future road widening, expansion of other utilities and special problems such as road, railway and power line crossings.
 - b. Safety and convenience of workers and the public.
2. Obtain necessary permits and easements for building and maintaining pole lines.
3. Coordinate with other utilities with respect to possible joint use and to minimize inductive interference.
4. Design the pole line for ultimate needs, taking into consideration pole line classification, storm loading, and clearance requirements.
5. Poles shall be of proper strength, class, and length to meet the weights of cables, wires and strands supported by them. See Table 6 in CPUC's G.O. 95 for the proper setting depths for various pole lengths
6. The most economical span length shall be used:
 - a. The span from the last pole to the building shall not exceed 100 feet.
 - b. Slack span construction shall be used.
 - c. Self-supporting cable shall be used.
 - d. Cable shall be placed on the roadside of the pole line.
7. For minimum clearances of distribution wires and cables over streets, sidewalks, agricultural areas, railroads, etc., see Rule 37 and Table 1 of CPUC's G.O. 95, the NESC, and TIA 758-A.
8. Aerial cables shall enter a building through a conduit with an approved service head.
9. Aerial cables shall be labeled upon entering and prior to exiting a building and MH/HH in accordance with Appendix A Specification 09, Outside Plant and Riser Cable Labeling Requirements.
10. Riser cables shall be located on the non-traffic side of poles.

7.5. Cable Splicing Methods and Splice Closures

A. Copper Cable Splice Methods

1. Copper telephone cables shall be spliced using a 710-type, 25-pair, large size, gray in color connector (710SC1-25, 710SD1-25, and 710TC1-25) for underground, direct-buried, aerial and building terminal splices. 710-type connectors shall be 3M-type or equal.

2. All splices shall be accomplished using the conductor fold-back method to ease future splicing and maintenance efforts.

B. Fiber Optic Cable Splice Methods

1. Confer with Communication Resources when designing the outside plant cable layout.

2. Should a field splice be required, both multimode and single-mode OSP fiber cables shall be spliced using a CR approved fusion splicing machine only. Mechanical splices shall not be allowed. Heat shrink type fusion protectors with a strength member shall be used for all fusion splices.

3. The larger 12-strand 12-inch size splice trays shall be used for both multimode and single-mode splices to allow additional space for retaining fiber loops and controlling bend radius.

4. A minimum of 30-feet of fiber optic cable (slack) shall be provided in the MH after splicing activities are completed. This slack is required to allow splicing activities to take place outside of the MH and in a controlled environment (e.g. splicing trailer/van). This slack shall be properly stored and lashed to the MH racks and shall not interfere with existing cables and splice closures.

5. All splices shall be inspected by a Communication Resources designated representative prior to sealing the splice.

C. Copper Cable Splice Closures

1. Copper cable splices (Aerial, Underground, and Direct-buried) shall be sealed using a bolt together, washer-less, stainless-steel type of closure with field adaptable/drillable/reusable 1, 2 and 3 section end plates to match the existing cable plant. Closure shall be Preformed Line Products® (PLP) or equal. No known equal.

2. The closure shall be sized to allow sufficient interior space for the fold-back method of splicing and to allow for the addition of future bridge spliced cables.

3. The closure shall be air pressure tested (flash-tested) upon installation and shall **not** be filled with encapsulant.

4. All splice closures shall be properly supported, racked and lashed to the MH racks. Closures shall be supported by their own individual cable steps, in addition to the steps used to support the cable itself.

5. All splice closures shall be properly grounded to the MH grounding and bonding system.
6. All splices shall be inspected by a Communication Resources designated representative prior to the completion and sealing of the splice.
7. All copper cables shall be labeled in accordance with Appendix A Specification 09, Outside Plant and Riser Cable Labeling Requirements.

D. Fiber Optic Splice Closures:

1. Fiber optic cable splices shall be sealed using a hard plastic, bolt together, re-useable/re-sealable type of fiber optic cable closure. Closure shall be Preformed Line Products® Coyote®, Corning Cable Systems®, or equal.
2. Closure shall allow manufacturer's recommended slack (typically 8 to 10 ft) within the closure to facilitate present and future fiber splicing and maintenance activities.
3. All splice closures shall be properly supported, racked and lashed to the MH racks. Closures shall be supported by their own individual cable steps, in addition to the steps used to support the cable itself.
4. All splice closures shall be properly grounded to the MH grounding system, when applicable.
5. All Fiber Optic cables shall be labeled in accordance with Appendix A Specification 09, Outside Plant and Riser Cable Labeling Requirements.

7.6. Building Entrance Terminals

- A. Outside Plant copper cables entering the ADF/BDF/IDF shall be terminated on wall-mounted building entrance protector terminal(s) equipped with gas tube (4B1-EW) protector modules. The 4B1-EW includes heat coils for sneak current protection.
- B. Building entrance terminals shall be equipped with full and lockable covers.
- C. Building entrance terminals shall not be located directly above the room entrance conduits, slots, or sleeves. Terminals shall be mounted in a location on the backboard that shall allow sufficient space for future cable and cross-connect installations.
- D. Copper entrance cables up to, but not including 100 pairs shall be terminated on protected building entrance terminals equipped with a splice chamber and factory installed large 710-type splice modules in the splice chamber (field side) and 110 type terminations on the output (equipment side). Cable shall be blocked with an approved manufactured seal to prevent the gel filled compound from escaping.

E. Copper entrance cables 100 pairs and larger shall be terminated on individual 100 pair protected terminals equipped with a factory installed, 26AWG swivel cable stub in the splice chamber (field side) and on the output (equipment side): stub-in, stub-out configuration. Cable stubs shall be no shorter than 2 feet in length after installation.

F. Factory cable stubs shall be spliced with 25-pair 710-type splice modules to the outside plant copper cable using the fold-back splice method. An indoor rated splice closure and 25-pair 710-type connectors shall be installed and securely mounted to the plywood backboard or existing cable ladder. Indoor closures shall not be encapsulated.

G. In addition to each building entrance terminal installed, a separate 110-type termination block shall be installed adjacent to the building entrance terminal and an indoor rated copper cable installed and terminated, pair for pair, to provide a separate cross-connect point for an up to, but not including 100 pair cable installation. For a 100 pair or larger cable use the factory installed 26AWG swivel cable. Reference Figure 7-3

H. All terminals shall be labeled in accordance with Appendix A Specification 09, Outside Plant and Riser Cable Labeling Requirements and properly grounded to the Telecommunications Grounding Busbar (TGB) in accordance with ANSI-J-STD-607-A.

7.7. Electrical Protection and Bonding/Grounding Requirements

A. All systems installed on the UC Davis campus shall conform to the California Electric Code (CEC) for electrical bonding/grounding requirements, in addition to those requirements in the ANSI/TIA/EIA-J-STD-607-A.

B. Reference Appendix A Specification 08, Electrical Protections, Bonding and Grounding.

C. All underground, direct-buried, and aerial cables (copper and fiber) shall be properly grounded and bonded at each end and at each splice location, where applicable.

7.8. Testing Requirements for Outside Plant Cables

A. All tests shall meet TIA 758-A requirements.

B. Campus outside plant copper and fiber optic cables shall be tested upon completion of installation. Reference Section 6.0, Communications Designers, Paragraph 6.10, for testing and documentation requirements.

C. All copper twisted pairs and fiber optic strands shall be tested from each end.

7.9. Labeling Requirements

All outside plant cables and termination housings shall be labeled in accordance ANSI/TIA/EIA 606-A and Appendix A Specification 09, Outside Plant and Riser Cable Labeling Requirements.

Figure 7-3 Building Entrance Terminal Layout

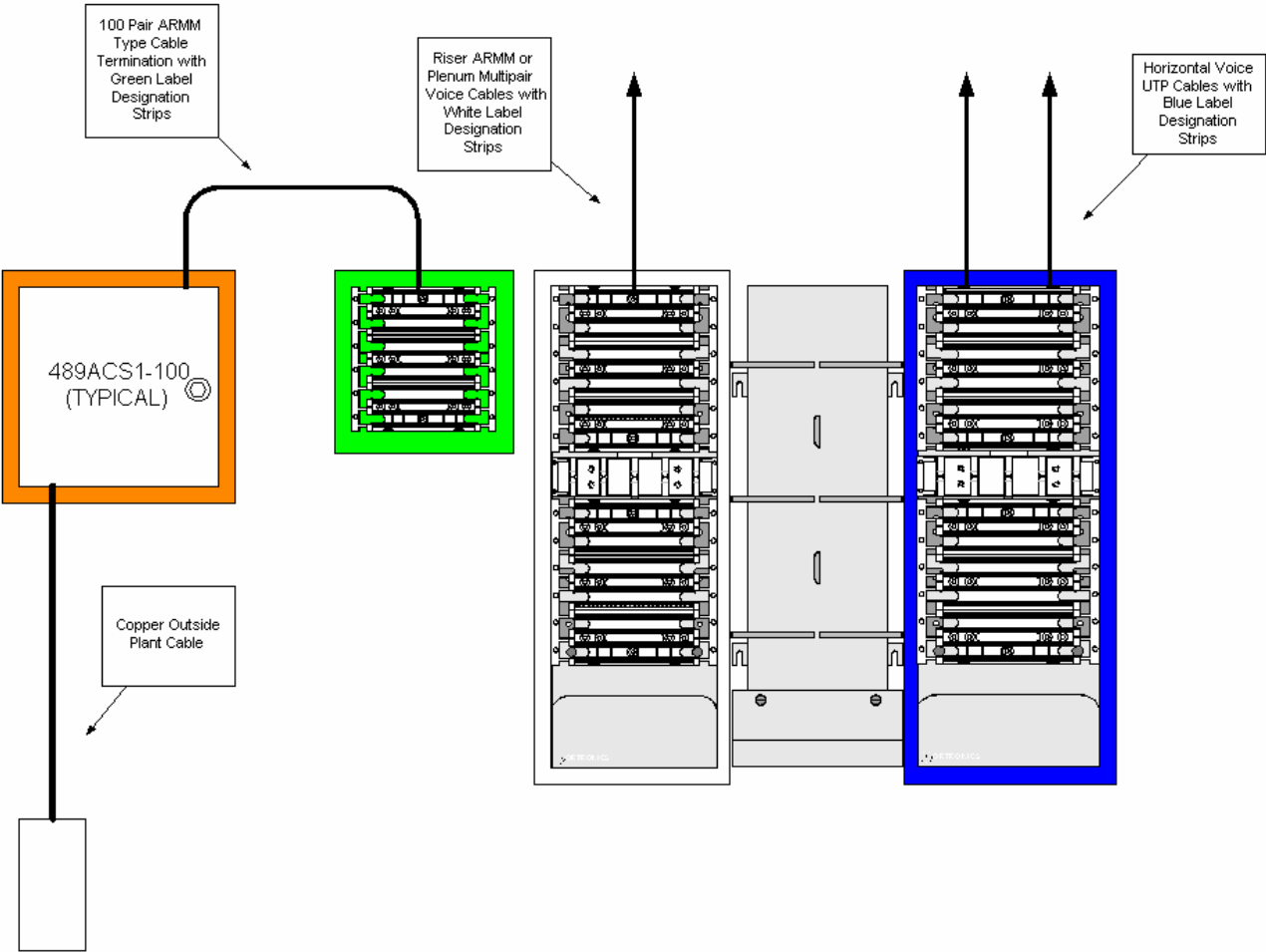

8.0 800 MHz IN-BUILDING RADIO SYSTEMS

8.1. The Design Process

- A. This chapter establishes the policies and procedures regarding 800 MHz in-building amplified radio systems required in new campus buildings.
- B. This chapter also covers the multi-level building needs assessment, specifications, type, cost evaluation, testing and acceptance of an in-building radio system.

8.2. General Radio Communications Coverage

- A. All buildings are required to support radio communications from the local public safety entities (Campus Fire, Police etc.)
- B. This section provides standards and guidance in support of the 800 MHz in-building radio communications systems. All capitol building projects exceeding 5,000 square feet (to include multi-level structures) are required to install, at a minimum, an amplification system on the first floor and basement. Additional performance coverage tests shall be performed before and during the construction phase to determine if additional in-building amplification is required for adequate coverage throughout the entire building.

8.3. Definitions

- A. BTS – Base Transceiver Station also known as the donor site.
- B. DBm – Decibels, in milli-watts. A unit of measure for RF signal level.
- C. Distributive Antenna – A system of non-radiating cable connected to an array of passive antenna.
- D. Donor – Base Transceiver Station also known as the donor site.
- E. Donor channel – The frequency in which the donor site transmits digital control information.
- F. Grade of Service – Typical service is stated as 95% coverage, 95% calls received and transmitted at Circuit Merit Level 3 (CM3). Reference Table 8-1, Circuit Merit Rating.
- G. Off-Air Repeater – A repeater that receives frequencies from an antenna and amplifies and retransmits those frequencies.
- H. NPSPAC – National Public Safety Planning and Advisory Committee.
- I. FCC – Federal Communications Commission.

J. Cross Modulation Ratio – The ratio of aural carrier level to coherent spurious signal level (i.e. inter-modulation products).

K. Carrier to Noise Ratio: The ratio of carrier to noise levels derived from 800 MHz in-building repeater measurements under design load at maximum output over the entire range of the specified frequency response.

L. IBAS – In-Building Amplification System

8.4. General

A. All buildings or structures located on the UC Davis campus shall support the clients of the UC Davis 800 MHz in-building trunked communications system. This standard also pertains to additions to existing buildings or structures of more than 20%. The clients of this communications system includes, but is not limited to, campus firefighters, police officers and emergency response personnel.

B. Adequate radio coverage shall include all of the following:

1. Installation of an IBAS system in the basement and first floor of qualified buildings to assure a minimum signal strength of -95 dBm in 95% of the area of each floor when transmitted from the campus central transceiver.
2. A minimum signal strength of -95 dBm available in 95% of the area of each additional floor of a building or structure when transmitted from the campus central transceiver.
3. A minimum signal strength of -95 dBm received at the campus central transceiver when transmitted from 95% of the area of all floors of a building.
4. The frequency range shall be 821-823 MHz and 866-868 MHz.
5. Radio frequency circuits of 50 ohms to shield and signal ground with Vertical Standing Wave Ratio (VSWR) not to exceed 1.5 to 1.
6. 100% reliability.

C. Amplification Systems. Buildings and structures shall be equipped with:

1. An internal multiple antenna system with FCC type accepted bi-directional 800 MHz amplifiers.
2. Radiating cable system (leaky coax).
3. An independent battery and/or generator system capable of providing at least twelve (12) hours of external power. The battery system shall automatically charge in the presence of an external power input.

4. Bi-directional amplifiers shall include filters to reduce adjacent frequency interference at least 35 dB below the NPSPAC band, if required. The filters shall be tuned to 825 and 870 MHz for operation, 35 dB below the NPSPAC frequencies of 824 and 869 MHz, respectively. Other frequency settings shall be used should these fail to attenuate the NPSPAC frequencies by more than one MHz.

5. Reference Table 8-2 for required antenna specifications.

6. A 1-inch conduit shall be dedicated from the equipment/telecommunications room (ER/TR) to a sealed junction box on the roof of the building for use as an antenna access point. This conduit shall be grounded using a path other than the telecommunications ground provided in the ER/TR.

D. Evaluation Process. The evaluation process for determining the need for additional in-building amplification on floors beyond the basement and first floor shall be conducted in a minimum of two phases: Pre-construction and construction.

1. Pre-construction Phase. Before the construction of the new building, basic information shall be gathered to begin the process of determining the type and actual implementation of an augmented radio system. In most cases, the following information shall be obtained to properly design and costs estimate an in-building radio system.

a. New Building Information.

- 1). Type/Size of building – single story, multi-level, square footage.
- 2). If multi-level, number of stories.
- 3). Orientation of building – above/below ground, line of sight.
- 4). Construction of exterior and interior walls. – Plaster, drywall, brick.
- 5). Proposed equipment locations – Equipment rooms, cableways and conduits.
- 6). Building location - Longitude and latitude coordinates.
- 7). Systems located in basement areas (below ground).
- 8). Verification of the riser antenna cable path from the basement area to the roof is required. The installation of a line-of-site antenna to the campus 800MHz tower shall be required.
- 9). Building blueprints or drawings.

b. Existing System Information.

- 1). BTS location – Longitude and latitude coordinates.
- 2). Donor channel frequency – Specific digital channel to enhance radio coverage.
- 3). Grade of service required to meet the objective.
- 4). Type of subscriber unit.
- 5). Number of channels and their frequencies.
- 6). Signal strength of donor site at the building location.

2. With the information above, the following steps shall establish a determination of the potential need for additional in-building radio system amplification beyond the basement and first floor.

3. Need Determination - Signal Strength Measurements. At the planned construction site, measure (or have measured) the signal strength of the donor control channel:

- a. If the signal strength of the donor is -95 dBm or less on the outside of the building, the probability of additional in-building coverage beyond the basement and first floor is high.
- b. If the signal strength of the donor is greater than -95 dBm, determine the expected signal strength of the donor by subtracting the sum of the interior losses, due to walls, doors and windows, from the ambient signal outside the building. (See Table 8-3)
- c. If a signal strength of -95 dBm or greater is calculated at the inner most point of the building, additional coverage on floors beyond the basement and first floor may not be required.
- d. If the signal strength is calculated at -95 dBm or less, an in-building system is warranted on all floors.

E. Construction Phase. As the construction progresses, refinements to the initial multi floor system estimate shall be made to ensure that the proposed IBAS will provide adequate coverage and to re-evaluate the impact on existing structures. A re-evaluation of the initial specifications shall help to fine-tune the proposed system size.

8.5. Testing and Acceptance

A. Once implemented, the IBAS system shall be tested via the pre-determined Acceptance Test Plan (ATP).

B. The ATP shall include personnel from Information and Educational Technology, Communications Resources, campus police, fire, safety and the vendor representative. A walk through test shall be completed and any discrepancies noted and resolved by the vendor.

C. Upon completion of the project installation, it shall be the A&E Project Manager's responsibility to have the radio system tested to ensure that two-way coverage on each floor of the building are within the general policy requirements as prescribed below⁸:

1. Each floor of the building shall be divided into a grid of approximately twenty (20) equal areas.
2. The test shall be conducted using a Motorola MTS 2000, or equivalent, portable radio, talking through the campus central transceiver. The radio shall be attached to the hip via a belt loop and equipped with an extension speaker/microphone and stubby quarter wave whip antenna.
3. A spot located approximately in the center of a grid area shall be selected for the test.
4. The radio shall be keyed to verify two-way communications to and from the outside of the building through the campus central transceiver.
5. Once the spot has been selected, prospecting for a better spot within the grid area shall not be permitted.
6. Each grid area shall be tested for transmission/reception, minimum signal strength of -95 dBm. If signal strength fails to meet the requirement, the grid area shall be marked as a fail.
7. A maximum of two (2) nonadjacent areas shall be allowed to fail the test. In the event that three (3) of the areas fail the test, the floor shall be divided into forty (40) equal areas. This shall provide for a more statistically accurate test.
8. In such event, a maximum of four (4) nonadjacent areas shall be allowed to fail the test.
9. Should the system continue to fail after the forty (40) area tests, the A&E project manager shall have the system altered to meet the 95% coverage requirement.

⁸ Overall project management of the implementation of an in-building coverage system should be offered and included in the turnkey proposal submitted.

10. The gain values of all amplifiers shall be measured and the test measurement results shall be kept on file with Communications Resources so that the measurements can be verified each year during the annual tests. In the event the measurement results become unavailable, the building owner shall be required to rerun the acceptance test to reestablish the gain values.

11. In addition to the radio set test listed above, a Radio Frequency Time Domain Reflectometer (RFTDR) with an operating range of 800-900 MHz and/or a Vertical Standing Wave Radio (VSWR) measurement test set shall also be used to provide a demonstrated conformance test result to Communications Resources.

8.6. Qualifications of Testing Personnel

A. Communications Resources shall be responsible for conducting or contracting system tests. All tests shall be conducted, documented and signed by a person in possession of a current FCC license, or a current technician certified by the Associated Public-Safety Communications Officials International (APCO) or the Personal Communications Industry Association (PCIA).

B. All test records shall be retained on the inspected premises and a copy submitted to Communications Resources and the campus Police/Fire Department officials.

Table 8-1 OES/ACS Circuit Merit Rating System

The California Governor's Office of Emergency Services (OES) Auxiliary Communications Service (ACS) Circuit Merit Rating System	
Rating	Transmission Quality
CM 5	Completely clear, each word fully understood.
CM 4	Clear with slight amount of static and/or interference.
CM 3	Static and/or interference present, but the bulk of the transmission is understood without having to be repeated. Deemed to be the margin of acceptable, professional communications.
CM 2	Static and interference are prevalent and words are missing.
CM 1	Signal is barely evident and words are not understandable.
CM 0	Nothing heard

Table 8-2 Antenna Specifications

ITEM	SPECIFICATIONS
Frequency Range	806 to 896 MHz
Gain over Isotropic	11 dB
VSWR	Not to exceed 1.4 to 1
Horizontal Beam width	90 degree \pm 5 degrees at -3 dB relative to normal axis
Vertical Beam width	30 degrees \pm 2 degrees at -3 dB relative to normal axis
Front to Back Ratio	20 dB
Polarization	Vertical
Maximum Power Input	250 watts at operation frequency
Termination	Type N female connector, exit at rear or bottom
Lighting Protection	All metal parts grounded.
Dimensions	Not to exceed 30-inches high, 8-inches wide, 4-inches deep
Maximum Exposed Area	2.0 square feet
Maximum Wind Speed Survival	Not less than 125 MPH
Back Panel	Passivated aluminum
Radiating Elements	Irradiated aluminum and brass or metal with equal weather resistance
Radome	ABS plastic
Mounting Hardware	Galvanized steel with attachment to vertical pipe, 2-inch schedule 40
Net weight	Not to exceed 10 pounds
Preferred and Recommended Manufacturer	Decibel Products DB862H90

Table 8-3 RF Loss Characteristics

ITEM	LOSS (dB)
Loss from Structured Components	
Ceiling Duct	1-8
Metal Pole (small)	3
Metal Catwalk	5
Large I-Beam	8-10
Concrete Block Wall	13-20
One Floor	20-30
One Floor and One Wall	40-50
Machinery	
Light Machinery	1-4
Metallic Hoppers	3-6
General Machinery (10-20 sq ft)	5-10
Heavy Machinery (>20 sq ft)	10-15
Inventory	
Light Textile	3-5
Empty Cardboard	3-6
Metal Inventory	4-7
Heavy Textile	8-11

Table 8-4 In-building RF Coverage System Cost Estimating

ITEM	COST
Coax Cable Installed	
Antenna Installed	
Amplifier Low Power Installed	
Amplifier High Power Installed	

9.0 WIRELESS NETWORK SYSTEMS

A. This chapter establishes the specifications, type, testing and acceptance of a wireless network system.

B. At the time of this of publication, the Engineering and Construction Management office, Communications Resources, is evaluating current and emerging wireless standards, as well as, the different manufacturer's wireless products.

C. This chapter will be updated in future revisions as this new system progresses.

10.0 MASTER ANTENNA TELEVISION (MATV) SYSTEM

10.1. The Design Process.

A. The UC Davis MATV system consists of two distinct systems – Baseband and Broadband (RF). In addition, the campus also supports another RF system for student housing known as the Resident Network or ResNet. The Broadband system (and ResNet) uses modulation and radio frequencies to distribute signals to campus locations. The two systems co-exist and provide connectivity to many of the campus general assignment classrooms and auditoriums. These systems consist of the following basic elements:

1. Headend – The building that contains the electronics for receiving and processing TV programs. The UC Davis MATV system provides channel operations with a bandwidth up to 1000 MHz.
2. Distribution System – A network of distribution media such as coax cable, amplifiers, and couplers and splitters. The equipment is normally located in the Building Distribution Frame (BDF) and Intermediate Distribution Frame (IDF). Performance of the broadband distribution system shall meet the forward path bandwidth of 49-1000 MHz (passive components) and a flat gain of no less than 32 dB. Cross modulation, composite triple beat and hum modulation shall be 3 dB or better. Active components shall operate to 1000 MHz.
3. Subscriber Drop – The coax cable and MATV Work Area Outlets (WAO) where the users connect their TV set.

B. In addition to the MATV system, the UC Davis campus employs Moving Picture Experts Group (Mpeg), Video over Internet Protocol (IP) and digital distribution to send sound and images throughout the campus. Some of the standards for these systems are still in development while others are more mature and have accepted industry practices that are observed on campus. In the future, a separate chapter within this standard will be included to expand on those distribution standards that involve these systems as they become more defined and/or deemed as a standard on this campus.

C. The hardware segment consists of the following elements:

1. Amplifiers. An amplifier is an electronic device that takes an incoming signal and increases the signal strength so that the signal can transmit a greater distance. An amplifier can be added at any point within a distribution system.
2. Coaxial cable. Coaxial cable, commonly called coax, is the most common media used for distribution of RF signals. A quad-shield type of coax cable is the campus preferred and recommended type.

3. Connectors. Connectors are installed on the end of a coaxial cable to provide electrical and mechanical connection to a system component. The standard connector for use on RG6 and RG11 coax cable is the "F" type connector. The standard connector for semi rigid aluminum coaxial cable is the pin connector.

4. Modulators. A modulator is an electronic device that modulates baseband video, audio and data signals to specific carrier frequencies for insertion into the broadband RF distribution system. Modulators are usually located in the Headend.

5. Demodulators. A demodulator is an electronic device that removes the modulation from broadband signals. Demodulators are usually located in the Headend. The output of a demodulator is baseband video and audio.

6. Drop Cables. A drop cable is the cable that is connected to a tap at one end and the back of the MATV WAO at the other end.

7. Equalizers. An equalizer is an electronic device with a frequency response that is the opposite of the cable that feeds into it. Equalizers compensate for the non-linear frequency response of the coaxial cable.

8. MATV WAO. An MATV WAO outlet is a wall-mounted faceplate with an F-type Network Access Module (NAM) installed. WAO's provide the interconnection between the distribution system and the subscribers' equipment.

D. The horizontal cable segment consists of the following cable elements:

1. The horizontal cable and connecting hardware that provide the means for transporting the broadband signals between the MATV WAO in the work area and the Intermediate Distribution Frame (IDF).

2. The horizontal cabling pathways and spaces that distribute and support the horizontal cable and connecting hardware between the MATV WAO and the IDF.

E. This section describes the policies and procedures for the following design activities:

1. Determining the type and number of MATV WAO's in the work area.

2. Identifying the types and lengths of cable used in the horizontal segment.

3. Determining termination hardware requirements at the MATV WAO and BDF/IDF.

4. Designing the structures needed to support the horizontal cabling.

5. Determining the broadband distribution equipment required.

6. Assigning the MATV NAM numbers to the appropriate locations.
7. Cable testing procedures.

10.2. The Type and Number of MATV WAO's

- A. The subscriber drop coax cable shall be terminated at the MATV WAO with a standard F type connector inserted in a standard single gang faceplate.
- B. Consultation with the building occupant and Communications Resources is required during the design process to identify the number and location of MATV WAO's to be installed.

10.3. Cable Types and Lengths

- A. UC Davis recognizes the following types of cables for use in interbuilding horizontal segment of an MATV system: Quad-shield RG6 and RG11.
- B. The length of the drop cable shall be no more than 90 m (295 ft).
- C. The loss difference between the shortest and longest drop cables from a tap should be no more than 7 dB. This shall provide the recommended signal level at the outlet of 3 dBmv to 10 dBmv.
- D. Coaxial cables installed in buildings must meet the same code requirements as telecommunications cables. All conductive cabling and associated components shall comply with Article 800 of the CEC.
- E. Cables installed in air-handling plenums shall be UL listed type CMP and comply with CEC 800-51(a). The UL listing shall be marked on the cable sheath.
- F. Horizontal coax cables shall be installed in one continuous length and shall not be spliced.
- G. Coax cable shall be labeled in the same manner as telecommunications cables. Reference Appendix A Specification 02 for labeling sequence.
- H. Reference Table 10-2 for coax cable specifications.

10.4. Termination hardware requirements at the MATV WAO and BDF/IDF.

- A. Each coax cable shall be terminated at the MATV WAO with an F-type connector, 180-degree exit, 75-ohm module. The F-type connector module shall match the color and appearance of the faceplate or patch panel to be installed. Reference Table 10-1 for recommended part number and minimum performance specifications. If the consultant or contractor requests substitutions to the listed products, then documented and demonstrated equivalency of the substituted

product shall be provided to CR for their review. Ortronics® TracJack™ is the preferred and recommended manufacturer, or equal.

B. The F-type connector module shall be inserted in a single port, fog white single gang faceplate. Faceplates shall be from the same manufacturer as the F type connector module to ensure proper fit, function and appearance. The module shall be in a standard Fog White color or shall match the existing décor of the room, to include metal type faceplates. Reference Table 10-1 for recommended part number and minimum performance specifications. If the consultant or contractor requests substitutions to the listed products, then documented and demonstrated equivalency of the substituted product shall be provided to CR for their review. Ortronics® TracJack™ is the preferred and recommended manufacturer, or equal.

C. A 4-inch × 4-inch × 2 1/8-inch electrical back box with a single gang plaster ring shall be used at each MATV WAO location. A minimum 1-inch EMT conduit shall be installed to the cable pathway support system. Conduit shall be sized appropriately for the fill rate of cable it is to accommodate. Reference Section 4 for additional information.

D. Each coax cable shall be terminated in the BDF/IDF and connected directly to the wall-mounted signal splitter. If required, the coax cables may also be terminated on a rack or wall-mounted patch panel with a .75 ohm F-type connector, 180-degree exit. A bend limiting strain relief bar shall be used with each patch panel to secure the terminated coax cable. Reference Table 10-1 for recommended part number and minimum performance specifications. If the consultant or contractor requests substitutions to the listed products, then documented and demonstrated equivalency of the substituted product shall be provided to CR for their review. Ortronics® TracJack™ is the preferred and recommended manufacturer, or equal.

E. Cable slack shall be provided at both ends of the cable run to accommodate future cabling system changes. Approximately 6-inches of slack at the WAO location and 6-feet of slack at the equipment end (headend).

F. Install 75Ohm terminator resistors at all unused system terminal points.

G. Maintain consistent absolute signal polarity at all connectors, patch panels and connection points accessible in the system.

H. Video and RF/Broadband connector convention (Signal, Connector, Wire):

1. Signal: signal phase, Connector: center pin, Wire: center conductor
2. Signal: anti-phase, Connector: shell, Wire: shield
3. Signal: ground, Connector: shell, Wire: shield

Table 10-1 MATV WAO/Patch Panel Termination Hardware

Ortronics® Part Number, or equal	Description	Minimum Performance Standard
OR-63700006	F-Connector, 180-degree, TracJack®, Fog White	Return Loss: > 25 dB @ 2GHz Insertion Loss: < 2 dB @ 2GHz
OR-63700006-00	F-Connector, 180-degree, TracJack®, Black	Return Loss: > 25 dB @ 2GHz Insertion Loss: < 2 dB @ 2GHz
OR-40300549	Faceplate, Single Gang, Holds 1 TracJack®, Fog White	
OR-401045290	Patch Panel, Holds 24 TracJack®, Black	
OR-60400199	Bend Limiting Strain Relief Bar	

10.5. Structures to Support the Horizontal Cabling

A. Special attention shall be provided when selecting and designing the type and layout of structures to support the horizontal cabling.

B. UC Davis requires that the space above the ceiling grid be used, whenever possible, to route the horizontal cabling.

C. Listed below are the steps needed to complete this phase of the design process:

1. Obtain an accurate set of floor plans.
2. Annotate, on the floor plan, the locations and types of MATV WAO's.
3. Annotate, on the floor plan, the locations of the equipment racks/cabinets located within the Equipment and Telecommunications Room for the BDF/IDF patch panel hardware. If these locations have not been identified, please reference Section 3.0, Architectural Requirements before proceeding with this section.
4. Verify that the distance from each MATV WAO to the IDF does not exceed the manufacturer's recommended distance for the type of coax cable to be installed. This distance shall include the planned cable path as well as any vertical transitions and maintenance slack at the termination points.

Note: Horizontal cable lengths that exceed the manufacturer's recommended distance shall require the relocation of the BDF/IDF or an additional IDF shall be added.

5. Sketch the route of the conduit and the cable tray on the floor plan.

Note: The preferred method of routing the horizontal cabling is to run conduit from the MATV WAO to a cable tray placed along natural building corridors. The cable tray then channels the cabling to the IDF. See Section 4.0, Electrical Requirements for conduit design considerations.

6. A 1-inch EMT conduit shall be used from the MATV WAO electrical back box to the cable tray. A 1-inch, or larger, if appropriate, EMT conduit shall also be used if the bulk of the cables to be supported exceed the recommended 40% fill ratio.

a. Flexible EMT conduit is restricted to a 20-foot length, if required, in accordance with TIA/EIA 569-B.

b. Conduits shall be appropriately firestopped in accordance with TIA/EIA 569-B, Annex A, and any/all local fire codes. All firestop installations shall be labeled in accordance with TIA/EIA 606-A.

c. Install conduit with a pull string with a minimum test rating of 200 pounds.

d. Conduit ends shall be reamed and bushed to eliminate sharp edges that can damage cables during installation or service.

7. Identify firewalls or fire rated barriers that shall be breached during cable installation.

Note: All horizontal pathways that penetrate fire rated barriers shall be firestopped in accordance with TIA/EIA 569-B, Annex A and local fire code and labeled in accordance with TIA/EIA 606-A. See Section 4.0, Electrical Requirements.

8. Conduit shall extend through the fire rated barrier when a fire rated barrier exists between the MATV WAO and cable tray.

9. Identify hard ceiling or ceilings with restricted access that shall be traversed during cable installation.

a. A minimum of three (3) trade size 4 EMT conduits shall be used in these areas.

b. Conduits shall be sized to ensure the 40% fill ratio is not exceeded.

c. The ends of the conduit shall be bonded and grounded. Conduit shall be grounded to the Telecommunications Grounding Busbar (TGB). Reference Section 4.0, Electrical Requirements.

d. Surface molding shall be used to route cables from the MATV WAO to the interstitial space in areas with limited ceiling access. Ortronics® or Wiremold® surface raceway is the preferred and recommended manufacturer to ensure compatibility with the Ortronics® faceplates and modules for fit, function and appearance. If substitutions are requested by the consultant/contractor, then documented and demonstrated equivalency shall be provided to CR for their review.

e. Conduit placed above hard or limited access ceiling shall following the installation requirements in Section 4.

10. Identify MATV WAO's that shall be located on walls that are not made of sheet rock construction such as plaster walls, concrete block walls, exterior walls and insulated walls. Written approval shall be obtained from the Manager, Engineering and Construction Management, Communications Resources, to use surface mounted MATV WAO's if these walls cannot be fished. Ortronics® or Wiremold® surface raceway is the preferred and recommended manufacturer to ensure compatibility with the Ortronics® faceplates and modules for fit, function and appearance. If substitutions are requested by the consultant/contractor, then documented and demonstrated equivalency shall be provided to CR for their review.

Note: Exterior walls, while furred and covered with sheet rock, may not provide the necessary clearance between the sheet rock and the backing material (commonly concrete block) for standard MATV WAO's.

11. The cable manufacturer's recommended maximum pulling tension shall **NOT** be exceeded during the installation process.

12. Annotate, on the floor plan, the cable paths that shall be supported with J-hooks or adjustable cable supports (Hanger Bags). The type and size of J-hook or hanger bag shall conform to the manufacturer's specification for size and number of cables, and the environment for which they are to be installed. This specification shall not be exceeded.

13. J-hooks and hanger bags shall be spaced a maximum of every 4 feet to support the cable as referenced in TIA/EIA 569-B and shall be annotated on the construction drawings.

10.6. Determining the broadband distribution equipment required.

A. The following is a list of broadband distribution equipment installed on the UC Davis campus:

1. Broadband indoor distribution amplifier, bi-directional, 1000 MHz:

a. Performance, Forward Path

1) Bandwidth: 49-1000 MHz

2) Flat Gain: Not less than 32 dB.

3) Cross modulation, composite triple beat and hum modulation each at 3 dB better than minimum system specifications herein.

b. Performance, Reverse Path

- 1) Bandwidth: 5-36 MHz
- 2) Flat Gain: Not less than 24 dB
- 3) Cross modulation, composite triple beat and hum modulation each at least 3 dB better than system specifications herein.

c. Manufacture

- 1) Blonder-Tongue BIDA100A with on-board active return amplifiers.
- 2) Scientific-Atlanta, Broadband Engineering, Triple Crown or equal

2. Broadband passives

a. General:

- 1) CATV grade, 50 to 1000 MHz forward path, 5 to 36 MHz reserve path.
- 2) Comply with FCC for signal leakage.

b. Directional couplers and taps manufacturers:

- 1) Blonder-Tongue SRT Series
- 2) Regal RMT6 Series
- 3) RMS 5500B Series and RMS Unitap Series
- 4) Scientific-Atlanta SAT2F, SAT4F.

c. Grounding Block:

- 1) Comply with CEC 820-7.
- 2) Manufacturer: Crown, Gilbert, Regal, Sachs Canada or equal.

d. RF Attenuator manufacturer: Blonder-Tongue FA Series, Regal RILA Series, RMS FAP Series or equal.

e. Splitter, 2 to 8-way type:

- 1) Two-way: SP-2
- 2) Three-way: SP-3
- 3) Four-way: BBOC4, SP-4
- 4) Eight-way: BBOS8, SP-8

f. Splitter, 2 to 8-way manufacturer:

- 1) Blonder-Tongue SXRS
- 2) Regal Blue Label Series
- 3) RMS CA-2000 Series
- 4) Scientific-Atlanta SAS2F, SAS3F.

g. Terminator, 75-ohm, F-type manufacturer:

- 1) Blonder-Tongue BTF-TP 4670
- 2) Crown TR-75H
- 3) Gilbert GTR59A
- 4) LRC "TRF"
- 5) Regal RF-59T
- 6) Or equal

h. F-type Connectors (to match type of cable): Blonder-Tongue Versatap Series, Crown, Gilbert, LRC, Raychem or equal.

10.7. Assigning the MATV NAM numbers

A. The MATV NAM matrices are used by the Communications Resources department in the application of operational databases for assignment of services to departments and other service related purposes. They are crucial to the implementation of service to the project. Reference Appendix A Specification 02 for additional information.

B. The Consultant shall obtain MATV NAM numbers from the CR Project Line Assigner. Contact the CR project manager for contact information.

C. All additional MATV NAM numbers shall be obtained only from the CR Project Line Assigner. MATV NAM numbers shall not be duplicated. The project consultant or design professional is responsible for the issuing of accurate MATV NAM numbers and drawings.

D. After MATV NAM numbers have been assigned to the floor plans, the consultant shall complete the MATV NAM matrices. Refer to Appendix A Specification 02 for information on matrices. MATV NAM matrices are to be completed at the beginning of Construction Document (CD) preparation. A hardcopy of MATV NAM matrices shall be provided to the A&E Project Manager and a MS-Excel 2000 spreadsheet file to be provided to Communications Resources.

E. The consultant shall ensure that specifications are placed in the contract documents that inform the cabling contractor regarding use and maintenance of the MATV NAM matrices for the project.

10.8 Cable Testing Procedures

A. General

1. Test and report on each intermediate cabling segment, including BDF/IDF to MATV WAO.
2. Test each end-to-end cable link.

B. Signal Loss in the Network. Four factors that must be considered when calculating losses in a network are cable loss, splitter loss, insertion loss and isolation loss.

1. Cable Loss. Cable loss is calculated based on the distance that a signal must travel along with the lowest and highest frequency transmitted on the system. When calculating cable loss, consider the:
 - a. Cable manufacturer's loss value, which is generally provided as a dB value per 100 m (328 ft) or per 100 m (328 ft) at several frequencies.
 - b. Transmission frequency of the signal. Due to signal losses at higher frequencies, calculate the loss for the lowest and highest frequency that the system shall deliver. This characteristic of coax cable is called cable tilt. Cable loss values are based on a temperature of 20 °C (68 °F) and shall vary slightly under different conditions. Like other current-carrying cables, CATV cables show increased resistance and loss at higher temperatures. However, it is usually safe to disregard temperature compensation calculations when dealing with interbuilding systems. Table 10-2 shows typical loss values per 30 m (100 ft) for the coax cable at the lowest and highest channels in a 60-channel system.

Table 10-2 Coax Cable Specifications

Specification	RG-6M	RG-11M
Use	Drop Feeder	Trunk and Riser Feeder
Loss at 55 MHz (dB)	1.60	4.40
Loss at 450 MHz (dB)	0.96	2.75
Manufacturer (Triple Shield)	Belden 1189A or 1189U	
	CommScope F6TSVV, F677TSVV	
	West Penn/CDT T841 or equal	
Manufacturer (Quad Shield, Flooded Jacket)	Belden 1190A	Belden 1618A
	CommScope F6SSEF, or equal	CommScope F11SSEF, or equal
Antenna and Headend Placement	Quad Shield and PVC Jacket	Quad Shield and PVC Jacket
Metallic Raceway Placement	Double Shield and PVC or PE Jacket	Double Shield and PVC or PE Jacket
Not in Raceway Placement	Triple or Hardline Shield and CEC 820-15 Jacket	Triple or Hardline Shield and CEC 820-15 Jacket

2. Splitter Loss. The insertion loss for a splitter is a direct function of the quantity of output ports. The higher the quantity of ports, the higher the insertion loss of each port.

3. Insertion Loss. Insertion loss is a measure of the attenuation of a signal between the input and output of a passive device. The unit of measure for insertion loss is the dB. The insertion loss for directional couplers and tap-offs is determined by the tap value. The lower the tap values the higher the insertion loss.

4. Isolation Loss. Isolation loss is loss associated with a tap. Each tap in a system reduces the signal from the trunk or feeder by a specific loss value, expressed in decibels.

5. A properly designed system shall provide a signal level between 3 dBmV and 10 dBmV to every MATV WAO on all channels.

C. Performance Testing. Performance testing involves two steps:

1. Aligning/balancing the system. Aligning and balancing the system involves adjusting the gain, tilt and/or sensitivity of the system's amplifiers (launch and distribution) to match the specified signal levels in the system design. The system's performance cannot be analyzed until this aligning and balancing is completed.

2. Testing the system and its components. Testing the system involves using the appropriate test equipment to ensure that the system (sweep and levels) and all its components meet the overall design specifications. The test equipment used should include, but is not limited to, a wide band oscilloscope, sync/test generator, RF generator, field strength meter (5-1000 MHz), spectrum analyzer (5-1000MHz), precision demodulator, true RMS audio digital volt-ohm millimeter, signal level meters (SLM) and time domain reflectometers (TDR). Generally, impedance, TDR and structural return loss tests are performed as a pre-installation check of the cable. Testing for signal uniformity is performed on installed cable using a SLM unit. The tests should ensure that the system and its components meet the specifications for:

- a. Distortion.
- b. Signal Uniformity
- c. Signal-to-Noise Ratio (SNR)
- d. Signal Ingress
- e. Hum Modulation

D. Performance Requirements. The MATV system shall meet the following performance requirements:

1. Compliance with Title 47, Code of Federal Regulations, Part 76, Cable Television Rules and Regulations.
2. Provide interference-free distribution of any of the scheduled UC Davis channels and allow for future distribution of internally generated forward and reverse channels.
3. Provide CATV compatible adjacent channel operation with bandwidth to at least 1000 MHz. Bandwidth of amplifiers shall be from 49 MHz to 1000 MHz in the forward direction, unless otherwise indicated.
4. Passive elements shall permit upstream (reverse channel) transmission of 5 MHz to 36 MHz sub-low band VHF television channels from the Headend to any MATV WAO.
5. Output levels of +6 to +12 dBmv from 54 MHz to 450 MHz nominal. +3 dBmv at output levels above 450 MHz. Tap off output level shall not exceed +15dBmV.
6. Signal level from any channel to any adjacent channel shall not vary more than 2 dB at the tap off location.
7. Long term variations in amplitude shall not exceed 3 dB.
8. Amplitude response within any channel shall not exceed +1.0 dB.

9. Amplitude response for the entire spectrum sector shall not exceed +/- 2 dB.
10. Visual carrier to noise ration shall not be less than 50 dB.
11. Composite triple beat ratio shall not be less than 55 dB.
12. Cross modulation ratio shall not be less then 57 dB.
13. Visual carrier to hum modulation ratio shall not be less than 63 dB.
14. Visual carrier to reflections ratio shall not be less than 46 dB.

11.0 AUDIO-VISUAL SYSTEMS

11.1. The Design Process.

A. UC Davis Audio-Visual (A/V) systems designed and installed in new campus facilities shall consist of one or more the following three basic elements:

1. Sound System. A complete sound system meeting the performance standards specified below to be complimented with an ADA-approved assisted listening system.
2. Video System. A complete video system consists of various display devices consistent with the intended use of the room and viewable from at least 80% of the room while meeting performance standards listed below.
3. Remote Control Systems. A microprocessor controlled audio-visual system provides for the remote control of the various media systems installed in a room. These systems shall follow the standards established by the Classroom committee's selection of the Smart Panel or equal, which enables a complete room display without extensive operations training.

B. The design of an A/V system shall be based upon customer requirements, as well as, the intended room function. The included electronic equipment shall be considered to be industry standards and along with it's cabling, shall be approved by a Communications Resources representative.

C. All A/V systems designed and installed shall meet the most current Americans with Disabilities Act (ADA) requirements, including assisted listening systems, visual access and accommodations. The design consultant shall ensure all requirements are addressed.

11.2. Performance Standards

All A/V systems shall meet, as a minimum, the following performance standards unless restricted by the published specifications of a specific piece of manufacturer's equipment.

A. Audio Signal:

1. Signal-to-Noise Ratio (including cross talk): 55 dB minimum.
2. Total Harmonic Distortion: 0.1% maximum from 20 Hz to 20,000 Hz.
3. Frequency Response: +/- -1.0 dB, 20 Hz to 20,000 Hz.

B. Audio Reproduction:

1. Signal-to-Noise Ratio (including cross talk): 55 dB minimum.
2. Total Harmonic Distortion: 1% maximum from 30 Hz to 15,000 Hz.

3. Sound Output Capability: Provide program levels of not less than 95 dB in the seating area without objectionable distortion, rattle or buzz. Several different samples, such as recorded music and microphones, shall be employed as test signals.

4. Hum and Noise: Hum and noise shall be inaudible (below the background noise level of the space) under normal operation and as observed in normal seat locations.

C. Video Signal:

1. Signal-to-noise Ratio (peak to RMS) un-weighted DC to 4.2 MHz: 55 dB minimum.

2. Cross talk: Cross talk (un-weighted DC to 4.2 MHz): 45 dB minimum.

3. Frequency Response: +/- 0.5 dB to 4.2 MHz.

4. Line and Field Tilt: 2% minimum.

5. Differential Gain: 3% maximum.

6. Differential Phase: 2°-degree maximum.

D. Video Timing:

1. System Timing: Synchronize coincidence within 50 nanoseconds.

2. Color Timing: Within 2°-degrees at 3.58 MHz.

E. Optical:

1. The light fall-off from the center of the projected image to all four corners, as measured at the projected image plane, shall not exceed 50% for video projector images and 35% from slide projector images.

2. Fixed projectors, lenses and cameras shall be solidly mounted and braced so there shall be no observable movement in the image induced by motor vibration or other mechanical operations.

F. Control System:

1. Correct functional operation for all specified controls.

2. Feedback of the active function at operator and wired remote stations.

3. Wireless systems neither shall be the source of, nor be affected by, radio-frequency interference to and from any external signal devices.

12.0 CADD DRAWING STANDARDS

12.1. Inside and Outside Plant Drawing Requirements

This section outlines the procedures for developing ISP and OSP communications drawings. Included in this section:

A. Table 12-1 shows the proper OSP drawing layering convention used for all communication copper and fiber optic cable, conduit and maintenance and hand holes. This convention applies to text, lines and symbols.

B. CADD communications drawings shall be produced using AutoCAD version 14 or later and saved in a DWG format.

Table 12-1 OSP Layer Convention Details

Layer Name	Layer Description	Layer Color	Layer Linetype
0	Blank	7 (White)	Continuous
Butterfly	Maintenance hole Butterfly and details	7 (White)	Continuous
Cable	Cable lines	12 (Dk.Red)	Continuous
Cable Splice	Cable Splice symbols	12 (Dk.Red)	Continuous
Cabletxt	Cable text	7 (White)	Continuous
Coax	Coax lines	4 (Cyan)	Continuous
Coaxtxt	Coax text	7(White)	Continuons
Conduit	Conduit line	104 (Green)	Continuous
Condtxt	Conduit text	7 (White)	Continuous
Fiber	Fiber lines & symbols	30 (Orange)	Continuous
Fibtxt	Fiber text	7 (White)	Continuous
Title	Title Block and North Arrow	7 (White)	Continuous
Mhcable	Manhole symbols (Cable Size 1"=40')	40 (Gold)	Continuous
Mhcabletxt	Manhole text (Cable Size 1"=40')	7 (White)	Continuous
Mhcond	Manhole symbols (Conduit Size 1"=200')	40 (Gold)	Continuous
Mhcondtxt	Manhole text (Conduit Size 1"=200')	7 (White)	Continuous

C. Figure 12-1 shows the proper format used for cable lines and callouts on the OSP copper cable plant drawings.

Figure 12-1 OSP Drawing Copper Cable Callout

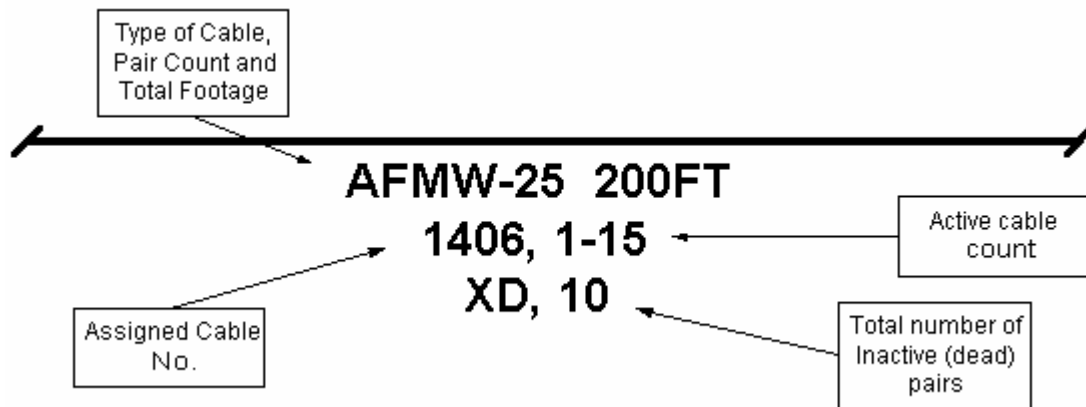

NOTE The Engineering and Construction Management, Communications Resources, office assigns and controls the fiber optic cable numbers. Contact the CR/ECM office for cable number assignment.

D. Figure 12-2 shows the unique numbering system for fiber optic cable.

Figure 12-2 OSP Drawing Fiber Optic Cable Unique Numbering System

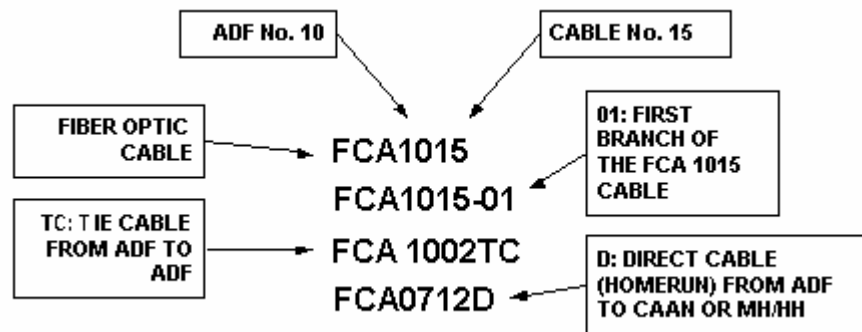

E. Figure 12-3 shows the proper format used for map labeling definitions for OSP fiber optic lines and callouts used on the communications drawings.

Figure 12-3 OSP Drawing CAA Fiber Optic Cable Callout

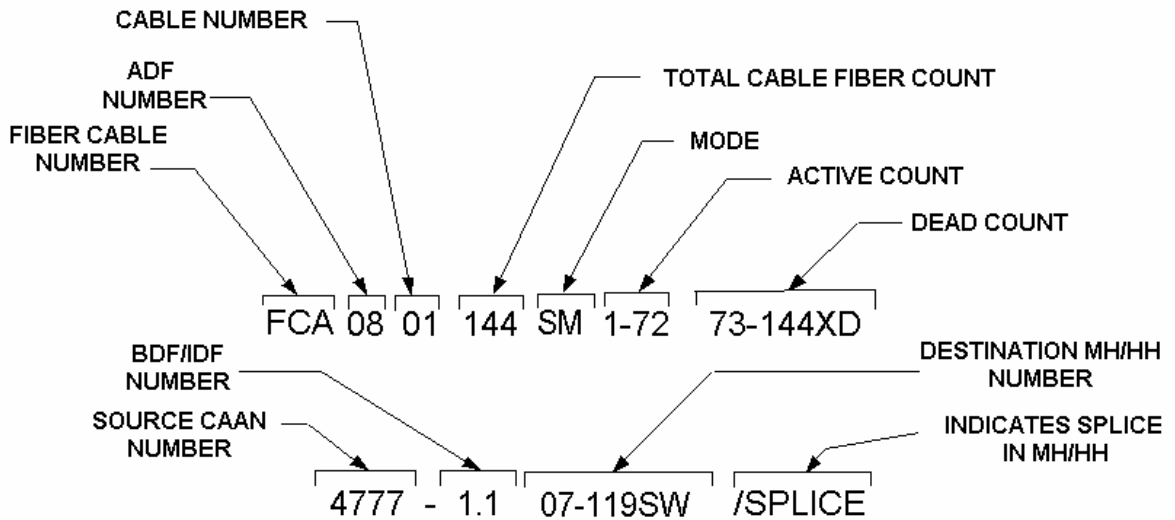

F. Figure 12-4 shows the proper format for map labeling definitions for maintenance and hand hole fiber optic cables and callouts used on the communications drawings.

Figure 12-4 OSP Drawing MH/HH Fiber Optic Cable Callout

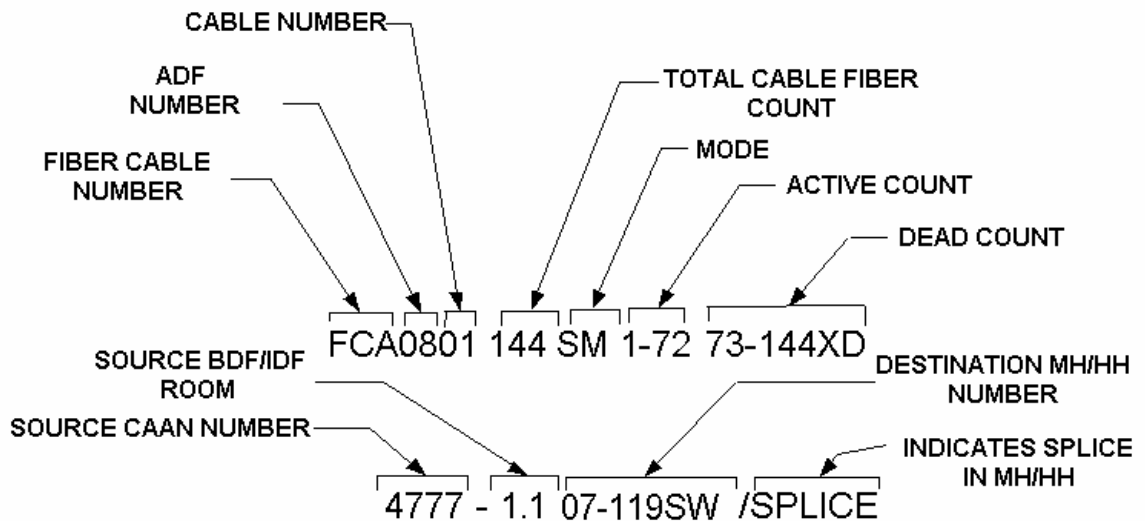

G. Figure 12-5 shows the proper format used for OSP copper cable terminal callouts on the communication drawings.

Figure 12-5 OSP Drawing Terminal Callouts

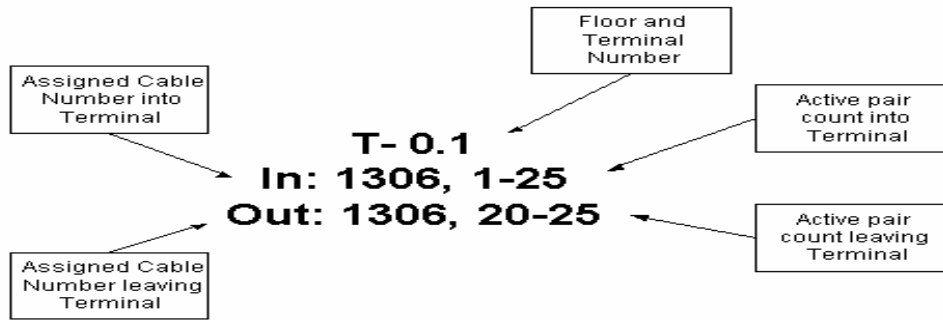





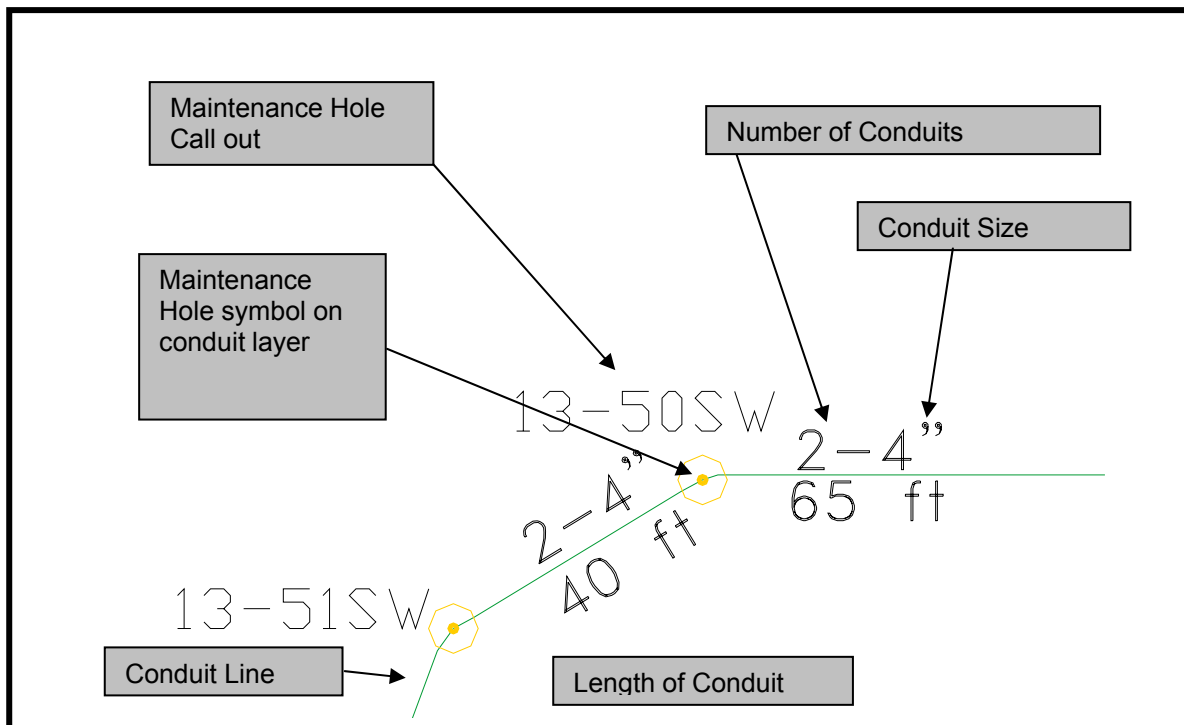

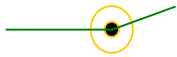

H. Figure 12-6 shows the proper format used for OSP conduit line and callouts on the communication drawings.

Figure 12-6 OSP Drawing Maintenance/Hand Hole and Conduit Callouts



I. Table 12-2 defines the cable symbols used on the communications drawings.

Table 12-2 OSP Cable Symbols and Descriptions

Symbol	Description	Layer Color	Layer Linetype
	Conduit MH on Conduit Layer	40 (Gold)	Continuous
	Fiber Symbol	30 (Orange)	Continuous
	Cable/Fiber MH Symbols	104 (Green)	Continuous
	Cable Straight Splice	12 (Red)	Continuous
	Cable Splice with Branch	12 (Red)	Continuous
	Cable Terminal Box Termination	12 (Red)	Continuous
	Cable Cross-Connect Hardware	12 (Red)	Continuous
	Fiber Optic Cable Termination	12 (Red)	Continuous

12.2. Inside Plant (ISP) drawing requirements











A. This section establishes the procedures regarding the development of inside plant (ISP) communications drawings.

B. Work Area Outlets (WAO), Area Distribution Frame's (ADF), Building Distribution Frame's (BDF) and Intermediate Distribution Frame's (IDF) symbols and callouts used on the communications drawings.

C. Layering convention for text fonts, line type, color, line thickness and name.

D. Size convention for symbols and text fonts.

Table 12-3 ISP Floor plan Symbols and Descriptions

Symbol	A- Description	Layer Color	Layer Name
	Indicates voice WAO	Cyan	NAM_ACTIVE
	Indicates data WAO	Cyan	NAM_ACTIVE
	Indicates wall phone	Cyan	NAM_ACTIVE
	Indicates combination WAO with one voice and one data NAM	Cyan	NAM_ACTIVE
	Indicates the WAO is located on furniture. Used for both voice and data.	Cyan	NAM_ACTIVE
	Indicates WAO located on the floor.	Cyan	NAM_ACTIVE
	Indicates fiber WAO	Cyan	NAM_ACTIVE
	Indicates where the terminal is located on the floor plan.	Magenta	TERMINAL
	Indicates Firewall	Orange	Firewall
	Indicates Double WAO (2 home runs of cable)	Cyan	NAM_ACTIVE
MATV	Indicates Master Antenna Television System	Cyan	NAM_ACTIVE
	Indicates a Wireless Access Point	Cyan	NAM_ACTIVE

The NAMS are located on the walls with the center point to the wall and the triangles are equilateral.

Table 12-4 ISP Floor Plans – NAM Reference Layers

Layer Name	Layer Description	Layer Color	Layer Linetype
Cable	Cable Runs	12 (Dk. Red)	Continuous
Fiber	Fiber Runs	30 (Orange)	Continuous with Fiber Symbols
Hor_pathway	Horizontal Cable/Fiber Pathways, Cable trays, J-hooks, & Panduit	104 (Green)	Continuous
Nam	All NAM Symbols with text	161(Lt. Blue)	Continuous
Notes	Miscellaneous Notes	7 (White)	Continuous
Room no	All floor plan room numbers	104 (Green)	Continuous
Terminals	All Comm. Terminals with text	6 (Magenta)	Continuous

Table 12-5 ISP Closet Bird's Eye Details – Comm. Room Layering Convention

Layer Name	Layer Description	Layer Color	Layer Linetype
7'-6" cabletray aff	7'-6" high cable tray Above Finish Floor	9 (Grey)	Continuous
8'-6" cabletray aff	8'-6" high cable tray Above Finish Floor	9 (Grey)	Continuous
Cabinets	Communication Cabinets	6 (Magenta)	Continuous
Cable	ISP Terminal Cable Runs	12 (Dk. Red)	Continuons
Coax	Coax	4 (Cyan)	Continuons
Conduits	Conduits	104 (Green)	Continuons
Dimensions	Dimension lines	7 (White)	Continuous
Fiber	ISP Terminal Fiber Runs	12 (Dk. Red)	Continuous
Misc-equip	Miscellaneous equipment	7 (White)	Continuous

12.3. Communications Drawing Requirements for Consultants and Contractors

A. Drawings submitted by consultants and contractors shall conform to the UCD Campus Standards & Design Guide, dated May 2003, Administrative Requirements and Content of Drawings. In addition, the guidelines provided in this section on OSP and ISP drawing requirements also shall apply.

B. Telecommunications drawing notes shall also indicate the year of the CR Telecommunications Standard that was used in the design of the project.

APPENDIX A

Specifications

[Specification 01 WAO Faceplates, Surface Mount Boxes, Wiremold® Adapter and Modules](#) 134

[Specification 02 NAM Numbering, Matrix and Labeling Requirements](#)..... 137

[Specification 03 WAO Cabling Requirements](#) 142

[Specification 04 WAO Copper and Fiber Patch Panel and Patch Cord Requirements](#)..... 145

[Specification 05 Indoor/Outside Plant Fiber Optic Cable Requirements](#)..... 152

[Specification 06 OSP/Riser/Backbone Fiber Optic Patch Panel/Patch Cords](#) 158

[Specification 07 Equipment Racks and Distribution Cabinets](#) 161

[Specification 08 Electrical Protections, Bonding and Grounding](#) 176

[Specification 09 Outside Plant and Riser Cable Labeling Requirements](#)..... 179

Specification 01 WAO Faceplates, Surface Mount Boxes, Wiremold® Adapter and Modules

These specifications provide a minimum configuration that shall be used when planning new construction or remodeling of an existing facility. Communications Resources shall be consulted early during the utilities planning phase of the project since each site may have technical requirements requiring a modification of these specifications.

- A. The Network Access Module (NAM) is the actual connector or jack installed in a faceplate or surface mounted box upon which the UTP, coax and fiber optic cable is terminated on in the work area.
- B. The term Work Area Outlet (WAO) refers to the actual faceplate or surface mounted box installed in the work area.
- C. Faceplates, Surface Mount Interface Boxes and 106-Type Receptacles:
1. WAO's shall be installed using fog white, flush-mounted, front entry, front removable, individual port faceplates and surface mount interface boxes. Faceplate color can also match the décor of the room area, to include metal type faceplates for laboratories, where required. Faceplates shall be Ortronics® TracJack®, or equal.
 2. WAO's providing multiple voice, data, video and fiber to the desktop (FTTD) service shall be installed using the faceplates listed in Table 01-1. All voice and data (to include FTTD) faceplates shall be a minimum of 4-port. Blank modules of the same color and manufacturer as the faceplate or surface mounted box shall cover all open ports not utilized by a NAM.
 3. 106-Type Receptacles, as listed in Table 01-1, shall be used when installing NAM's in metallic type surface raceways using standard electrical duplex receptacle type faceplates.
 4. Table 01-1 provides a summary of preferred and recommended faceplate products.
 5. Modular furniture adapters, bezels and brackets shall be used when installing NAM modules on modular furniture and Wiremold® raceway products. Adapters, bezels and brackets shall meet the manufacturer's specific requirements for their product to ensure fit, function and appearance. The color of the adapters, bezels and brackets shall match the particular furniture or Wiremold® item to ensure proper fit, function and appearance. Reference Table 01-2 for a list of Wiremold® and Ortronics® products for raceway installations. Adapters, bezels and brackets shall be Ortronics® TracJack®, or equal.
 6. Provide an angled faceplate in the Dorm Rooms.

D. Copper NAM Modules.

1. UTP cable providing voice and data service shall be terminated on Cat 5e, 8P8C, T568A, 180-degree exit, front installable and front re-moveable modules. Performance testing shall be conducted at the component level by a UL certified testing laboratory and include active live channel testing to ensure manufacturer and performance quality. Modules shall be Ortronics® Clarity^{5E}, TracJack®, or equal.
2. The campus standard module colors are orange for data and fog white for voice. No substitutions to these colors are permitted.
3. Modules shall be manufactured by an ISO 9001 certified manufacturer and be fully compliant with ISO/IEC/DIS-11801 standard and meet FCC specifications where applicable. These products shall be UL® certified where applicable
4. Table 01-3 provides a summary of approved modules.
5. Blank modules shall be installed in all vacant faceplate and surface mounted box ports. Blank color shall match the color of the faceplate or box and shall be from the same manufacturer as the faceplate to ensure fit, function and appearance.

Table 01-1 WAO Faceplates and Surface Mount Boxes

Wiremold® Part Number, or equal	Description
CM-SAP	CM Series Single Gang Angled Faceplate, Ivory
CM2-U2TJ	CM2 Module for TracJack, Ivory
Ortronics® Part Number, or equal.	Description
OR-40300546	Single Gang, Holds 4 TracJack®, Fog White, Front Entry/Removable
OR-40300545	Single Gang, Holds 6 TracJack®, Fog White, Front Entry/Removable
OR-40300555	Dual Gang, Holds 6 TracJack®, Fog White, Front Entry/Removable
OR-40300554	Dual Gang, Holds 8 TracJack®, Fog White, Front Entry/Removable
OR-40300185	Surface Mount Box, Single Gang, Fog White, Front Entry/Removable
OR-40400054	Surface Mount Box, 2-Port, TracJack®, Fog White, Front Entry/Removable
OR-40400072	Surface Mount Box, 4-Port, TracJack®, Fog White, Front Entry/Removable
OR-40800017	106-Type Receptacles, 2-Port, TracJack®, Fog White, Front Entry/Removable
OR-40800019	106-Type Receptacles, 4-Port, TracJack®, Fog White, Front Entry/Removable
OR-854045212	Single Gang, Holds 1 TracJack® for Wall-Mounted Telephone, Stainless Steel

Table 01-2 Wiremold® and Ortronics® Raceway Products

Wiremold® Part Number, or equal	Description
ALA-LPB3S2	Low Profile Bezel Cover Plate
Ortronics® Part Number, or equal	Description
OR-40300656*	Series II Angled Bezel for TracJack® Modules, Fog White, Front Entry/Removable
OR-40300023*	Series II Blank Module, Fog White, Front Entry/Removable
*Actual color to match Wiremold Raceway and Low Profile Bezel Cover Plate as available from manufacturer	

E. Fiber Optic Modules. Single-mode fiber optic cable providing fiber to the desktop (FTTD) service shall be terminated on LC-type fiber optic modules.

1. The LC-type module shall be front entry installable and re-moveable and shall be of the same manufacturer as the faceplate to ensure fit, function and appearance. LC-type module shall be Ortronics® TracJack®, or equal.
2. Table 01-3 provides a summary of approved modules.

Table 01-3 Copper and Fiber NAM Modules

Ortronics® Part Number, or equal.	Description
OR-TJ5E00-23	TracJack®, RJ-45 Module, 8P8C, T568A/B, 180° degree exit, Orange for Data, Front Entry/Removable
OR-TJ5E00	TracJack® RJ-45 Module, 8P8C, T568A/B, 180° degree exit, Fog White for Voice, Front Entry/Removable
OR-42100002	TracJack® Blank Module, Fog White, Front Entry/Removable
OR-63700031	TracJack® LC Single-mode, Angled, 45° degree exit, 2 fibers, feed through, Blue, Front Entry/Removable
OR-63700006	TracJack® F-Connector, 180° degree exit, 75 Ohm, Front Entry/Removable

Specification 02 NAM Numbering, Matrix and Labeling Requirements

These specifications provide a minimum configuration that shall be used when planning new construction or major remodeling of an existing facility. Communications Resources shall be consulted early during the utilities planning phase of the project since each site may have technical requirements requiring a modification of these specifications.

A. NAM Numbering:

1. Contact the Communication Resources (CR) CR Project Line Assigner to obtain blocks of NAM numbers for project assignment. Contact the A&E project manager for information.
2. The CR CR Project Line Assigner will need to know how many voice, data, fiber to the desktop (FTTD) and master antenna television (MATV) NAM numbers the project consultant requires.
3. Assign the NAM numbers to the floor plans.

B. NAM Matrices:

1. Specify that the contractor shall provide a cross connect sheet (NAM voice, data, master antenna television [MATV] and fiber to the desktop [FTTD] Matrix), which identifies all cross-connects from the NAM to the IDF. Reference Tables 02-1, 02-2, 02-3 and 02-4.
2. Specify that the contractor shall use and update the NAM Matrices during the project construction.

C. NAM Labeling: The UC Davis Communications Resources CR Project Line Assigner shall provide the project consultant a unique 6-digit (7-digit for FTTD) NAM number. This number is also referred to as a NAM ID. NAM's are to be labeled either on a pre-printed label or using an electronic label maker such as the Brother P-Touch[®]. The electronic label shall contain black, Helvetica, Size 1 Font, block letters on a white background. When printing labels on a desktop printer, the size and type of font shall be black, Helvetica, size 10, block letters on a white background.

1. The NAM number shall be placed in the window area on the faceplate above and below the NAM in the space provided as shown in Figure 02-1.
2. On a 6-port faceplate, the NAM label shall be placed to the side of the NAM's installed in the center ports. As shown in figure 02-1.
3. When a surface mounted interface box is used, the top of the box shall be labeled as shown in Figure 02-2.

4. Flush mounted Fiber to the Desktop (FTTD) NAM's shall be labeled as shown in Figure 02-3.

Figure 02-1 Labeling Flush Mounted WAO

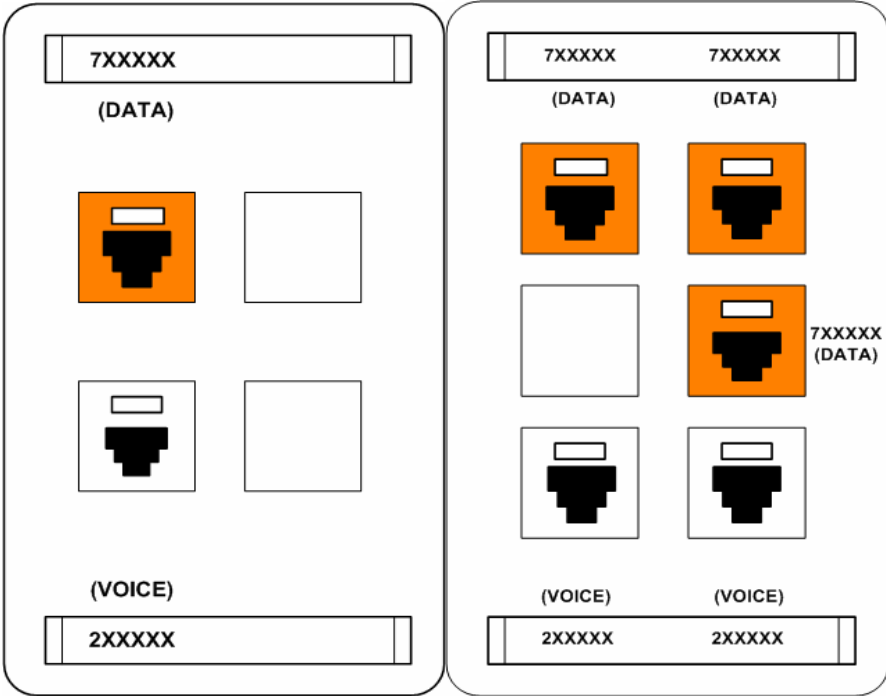

Figure 02-2 Labeling Surface Mounted WAO

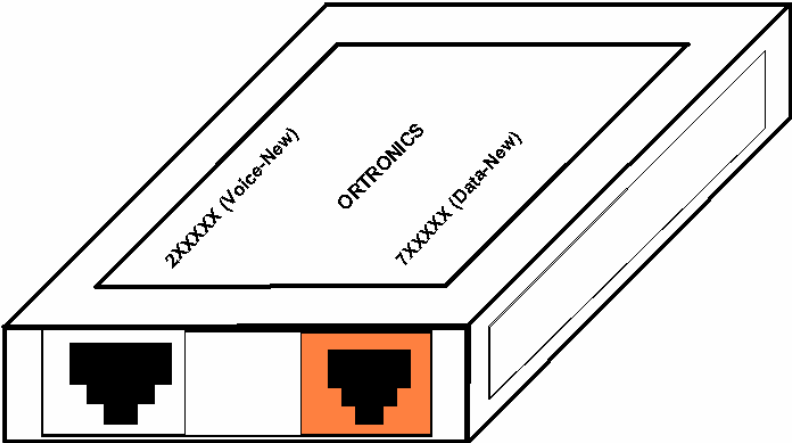

Figure 02-3 Labeling Flush Mounted FTTD WAO

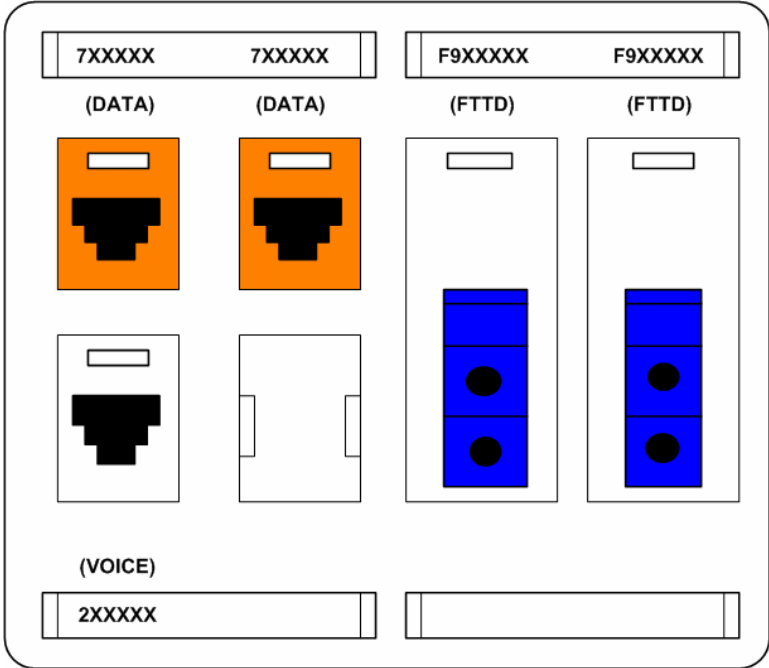

Table 02-1 VOICE NAM MATRIX

Bldg:
CAAN:
Zone:

NAM ROOM #	VOICE NAM #	IDF TERM #	BDF/IDF ROOM #	BDF/IDF TERM #	REFERENCE DRAWING #	RISER CABLE #	RISER PAIR #

Specification 03 WAO Cabling Requirements

These specifications provide a minimum configuration that shall be used when planning new construction or major remodeling of an existing facility. Communications Resources shall be consulted early during the utilities planning phase of the project since each site may have technical requirements requiring a modification of these specifications.

A. WAO's providing voice and data service shall be cabled with a 4-pair, 24AWG, Unshielded Twisted Pair Cable. The following Berk-Tek™ LANMARK-350 manufacturer part numbers are the preferred and recommended manufacturer.

1. Berk-Tek™ LANMARK-350, Non-Plenum, 10032434, White Jacket for voice circuits, or equal.
2. Berk-Tek™ LANMARK-350 Plenum, 10032072, White Jacket for voice circuits, or equal.
3. Berk-Tek™ LANMARK-350 Non-Plenum, 10032426, Blue Jacket for data circuits, or equal.
4. Berk-Tek™ LANMARK-350 Plenum, 10032065, Blue Jacket for data circuits, or equal.
5. Low Smoke, CMP-50, FEP, clear jacket for voice and data circuits located in student co-habitation areas **may** be required by state and campus fire code. The project consultant or installing contractor shall verify this prior to the design and installation of any cable in these areas. Cable shall be Berk-Tek™ LANMARK-350, PN# 235030, or equal.

B. Cable shall be manufactured, tested, certified and meet the performance requirements listed in Table 03-1. Performance requirements shall be tested at the 250 MHz level, as a minimum. Performance testing shall be conducted at the component level by a UL certified testing laboratory and include active live channel testing to ensure manufacturer and performance quality. Documentation of this performance test shall be provided to CR prior to installation.

C. WAO's providing fiber to the desktop (FTTD) service shall be cabled using riser rated or plenum rated single-mode fiber optic cable. Cable shall be Corning Cable System® Infinicor MIC® cable, or equal.

D. Single-mode interior cable shall meet the following specifications:

1. 4-fiber, 8.3/125, tight-buffered, OFNR (Riser), OFNP (Plenum) rated.
2. Maximum Attenuation: 1.0/0.75 dB/km at 1310 and 1550nm.
3. Gigabit Ethernet Distance Guarantee: 5000 meters.

4. Non-Plenum part number: 004R81-31131-24, or equal.

5. Plenum part number: 004R88-31131-29, or equal.

Table 03-1 Copper UTP Cable Specifications

Copper UTP Cable	Specifications
Construction	0.52mm (24AWG), bare copper wire insulated with polyethylene (non-plenum) or FEP (plenum). Two insulated conductors, non-bonded, twisted together to form a pair and four such pairs lay up to form the basic unit jacketed with flame-retardant PVC.
Physical Data	Conductor diameter: .020 inches Maximum Cable Diameter: .187-inches (non-plenum) .165-inches (plenum) Nominal cable weight: 22 lb/kft Maximum installation tension: 25 lb Minimum bend radius: 1.0 inches Available in easily identified pull or reel in box with large flanged, no tangle cones for easy cable payout to lessen the number of kinks in cable and ensure full performance.
Electrical Data (tested at 350MHz) for Non-Plenum	SRL: 18.4 dB/100m Return Loss: 18.4 dB Attenuation: 44.4 dB Power Sum NEXT: 30.0 dB NEXT: 32.0 dB ACR: 4.8 dB Power Sum-ACR: 2.4 ELFEXT: 35.4 dB PS-ELFEXT: 25.2 dB
Parametric Measurement (tested at 100 meters)	Mutual Capacitance: 4.4 nF DC resistance: 9.38 ohms Skew: 25 ns Pair to Ground Unbalance: 330 pF Velocity of Propagation: 70% (Non-plenum) 72% (Plenum) Characteristic/Input Impedance: $100 \pm 14 + 15 \log(F/100)$ 100-500MHz ISO/IEC 11801 ± 14 ohm impedance control at 100-350 MHz 99+% factory yield Manufacturer guarantee above standard Cat 5e permanent link and channel performance
Active Live Channel Testing	0.17 Errors per minute allowable
Preferred/Recommended Manufacturer	Berk-Tek® LANMARK-350, or equal.

Table 03-2 Horizontal Fiber Optic Cable Specifications

Horizontal Fiber Optic Cable, Single-mode (SM)	Specification
Construction	900 micron TBII buffered fibers wrapped in an all-dielectric strength member, ripcord and polyvinyl chloride outer jacket. All components of the complete cable product (glass, inner/outer sheath and jacketing material) shall be from the same manufacturer to ensure quality, performance, fit, function and warranty of product.
Core Diameter	8.3 μm
Cladding Diameter	125.0 (+/-) 2.0 μm
Fiber Strand Coating	Coating to be easily mechanically strippable, dual layered, UV-Cured acrylate applied by the fiber manufacturer
Maximum Attenuation (SM)	1.0dB @ 1310nm, 0.75dB @ 1550nm
Gigabit Ethernet Distance Guarantee (SM)	5000 meters at 1310nm
Preferred/Recommended Manufacturer:	Corning Cable Systems® MIC® Cable, or equal.

Specification 04 WAO Copper and Fiber Patch Panel and Patch Cord Requirements

These specifications provide a minimum configuration that shall be used when planning new construction or major remodeling of an existing facility. Communications Resources shall be consulted early during the utilities planning phase of the project since each site may have technical requirements requiring a modification of these specifications.

A. Data Patch Panels. UTP cable patch panels that provide data service to WAO's shall meet the following specifications:

1. High density, 8 port 8P8C module groupings on the front to 110-type IDC PCB mounted connectors on the back providing termination for 22-26 AWG solid horizontal distribution cables. Panels shall have front and rear labeling designation strips and rear cable management. Terminate 8P8C modules with universal T568A wiring.
2. Patch Panels shall meet specified performance requirements as listed in Table 04-1. Performance testing shall be conducted at the component level by a UL certified testing laboratory and include active live channel testing to ensure manufacturer and performance quality. Table 04-1 lists performance requirements tested at 350 MHz.
3. Patch panels shall be manufactured by an ISO 9001 Certified Manufacturer and be fully compliant with ISO/IEC/DIS-11801 standard and meet FCC specifications where applicable. These products shall also be UL® certified, where applicable.
4. The patch panels shall be labeled above the 8P8C module as shown in Figure 04-1.
5. Ortronics® Clarity^{5E}, Part number OR-PHD5E8U24 (24 port), or equal.
6. Ortronics® Clarity^{5E}, Part number OR-PHD5E8U48 (48 port), or equal.
7. Ortronics Cable Management Panel, OR-808044855 or equal is used in conjunction with the above patch panels.

B. Voice UTP Cable Termination Blocks. Voice UTP cables that provides voice service to WAO's and cross-connects for Digital Loop Carrier systems shall be installed using the following preferred and recommended products.

1. Wall-mountable 110-type cross connect termination blocks with backboard. This system shall be installed as a complete kit to include 110-type blocks, 110-C type connecting blocks, jumper trough, bottom tray and labels. Termination kit shall be Ortronics®, Systimax® or equal.
2. Wall-mountable 110-type cross connect termination blocks shall support the appropriate Category 5e rating and facilitate cross connection and/or intermediate cross connection using either cross-connect wire or patch cords. The cross-connect

hardware shall be of the same manufacturer as the 110-type patch panel to insure compatibility, function, fit and appearance.

Table 04-1 Data Patch Panel Specifications

Data Patch Panel Termination Hardware	Specifications
Construction (24 and 48 Port Patch Panels)	Category 5e to 110 IDC, 568A wiring, 8P8C, high density, 8 port, rear cable management, front and rear designation strips, 19" (483mm) wide by 1.75" (45mm) high (24 port) and 3.5" (89mm) high (48 port), Low emission IDC contacts, TIA/EIA 568-B.2 compliant and UL® Listed
Electrical Data (tested at 250MHz)	Return Loss: 21.0 dB
	Attenuation: 0.4 dB
	Power Sum-NEXT: 41.0 dB
	Power Sum-ELFEXT: 34.0 dB
	Power Sum-ACR Channel: 4.9 dB
Active Live Channel Testing	0.17 errors per minute allowable
Preferred/Recommended Manufacturer	Ortronics® Clarity ^{5E} , High Density, 8 port modules, 24-port and 48-port, or equal.

3. The top of the 110-type block shall be mounted on a plywood backboard at a maximum height of 66-inches Above Finished Floor (AFF).
4. Manufactured of flame-retardant thermoplastic, with the base consisting of horizontal index strips for termination of up to 25-pairs of conductors.
5. Manufactured in 50-, 100-, 300- and 900-pair size kits.
6. Non-detachable standoff legs available for the 50-, 100- 300- and 900-pair bases.
7. Contain access opening for rear to front cable routing to the point of termination.
8. Termination strips on the base to be notched and divided into 5-pair increments.
9. Clear label holders with the appropriate colored inserts available for the wiring blocks. The insert labels provided with the product shall contain vertical lines spaced on the basis of circuit size (1-, 3-, 4- or 5-pair) and shall not interfere with running, tracing or removing jumper wire/patch cords. Contact CR for required color code of these labels prior to installation.
10. Bases available with 19-inch panels and high-density frame configurations for rack or wall mounting with cable management hardware.
11. Connecting blocks used for either the termination of cross-connect (jumper) wire or patch cords. The connecting blocks shall be available in 2-, 3-, 4-, and 5-pair sizes. All connecting blocks shall have color-coded tip and ring designation markers and be single piece construction.

12. Connecting blocks with a minimum of 200 re-terminations without signal degradation below standards compliance limit.

13. Support wire sizes: Solid 22-26 AWG (0.64 mm – 0.40 mm).

14. Electrical Specification:

a. ANSI/TIA/EIA-568-B.1, B.2 and Category 5e compliant in both design and performance.

b. The requirements listed in Table 04-1 shall also be met.

c. Be UL LISTED 1863, Communications Circuit Accessories, 1995.

d. 110-type connecting blocks shall be manufactured by an ISO 9001 Certified Manufacturers, and be fully compliant with ISO/IEC/DIS-11801 standard and meet FCC specifications where applicable. These products shall also be UL® certified, where applicable.

C. Fiber to the Desktop (FTTD) Patch Panels. FTTD patch panels that provide fiber service to WAO's shall be terminated using the following preferred and recommended products.

1. Corning Cable Systems® Closet Connector Housings, Rack-mountable, or equal:

a. CCH-01U (48 fibers)

b. CCH-02U (96 fibers)

c. CCH-03U (144 fibers)

d. CCH-04U (288 fibers)

2. Corning Cable Systems® Closet Connector Housings, Wall-mountable, or equal:

a. WCH-02P (24 fibers)

b. WCH-04P (48 fibers)

c. WCH-06P (72 fibers)

d. WCH-08P (96 fibers)

e. WCH-12P (144 fibers)

3. Corning Cable Systems® Closet Connector Housing Panels, Single-mode LC Adapter Duplex, or equal:

a. CCH-CP06-A9

b. CCH-CP12-A9

4. Corning Cable Systems Unicam® Single-mode LC Ultra Polish connector, Part number 98-200-98, or equal.
5. All rack and wall-mounted fiber optic closet connector housings shall be labeled in accordance with Figure 04-2. The background color of the housing label shall be yellow in color to match the type of fiber strand terminated.
6. Housing and connector panels shall be of the same manufacturer as the fiber optic cable and connectors to ensure proper compatibility, fit, function, appearance and the highest campus wide system performance levels and warranty.

C. Data Patch Cords.

1. Table 04-2 lists the preferred and recommended manufacturer of patch cord providing data service to WAO's.
2. Patch cords shall be from the same manufacturer as the termination (patch panels and NAM modules) hardware to ensure proper compatibility, fit, function, appearance and the highest campus wide system performance levels and warranty.
3. Patch cords are designed to work best with components from the same manufacturer or from manufacturers that design their products to work with that specific patch cord.
4. Performance testing of patch cords shall be conducted at the component level by a UL certified testing laboratory to ensure performance, compatibility, fit, function, appearance and warranty. Performance testing shall include active live channel testing to ensure manufacturer and performance quality.
5. Manufactured patch cords shall be installed to meet the minimum bending radius of 0.25 inches as specified in ANSI/TIA/EIA 568-B.1-AD-1, Sub clause Addendum 10.2.1.3
6. Patch cords shall be manufactured by a TL 9000 and ISO 9001 Certified Manufacturer and be fully compliant with ISO/IEC/DIS-11801 standards and meet FCC specifications where applicable. These products shall also be UL® certified, where applicable. Field fabricated patch cords are not allowed.

D. Voice Cross-Connect Wire.

1. Specify that the contractor shall provide sufficient jumper wire (blue/yellow, 24AWG for voice, white/red, 24AWG for Fire Systems) to complete all identified cross-connects by CR personnel at the ADF/BDF locations.
2. Proper selection and installation of cross-connect jumper wire used between cross-connect blocks is essential to the overall performance of the network.
3. Cross-connect jumper wire shall be of the same or higher transmission category as the cross-connect block. The twist shall be maintained to within 0.5 inches of the entry into the cross-connect block.

4. Contractors shall complete the horizontal and riser cross-connections at the BDF and IDF location(s).

E. Fiber to the Desktop (FTTD) Patch Cords.

1. Table 04-3 lists the preferred and recommended manufacturer of duplex patch cords providing FTTD service to WAO's.

2. Patch cords shall be from the same manufacturer as the termination hardware and cable (patch panels and LC type connectors) to ensure proper compatibility, fit, function, appearance and the highest campus wide system performance levels and warranty. If substitutions are requested by the consultant/contractor, then documented and demonstrated equivalency shall be provided to CR for review and acceptance.

3. Patch cords are designed to work best with components from the same manufacturer and from manufacturers who design their products to work with that specific patch cord.

4. Patch cords shall be manufactured by a TL 9000 and ISO 9001 Certified Manufacturer and be fully compliant with ISO/IEC/DIS-11801 standard and meet FCC specifications where applicable. These products shall also be UL® certified, where applicable.

Table 04-2 Manufactured Data Patch Cords Lengths/Specifications

Manufactured Patch Cords	Maximum Length/Performance	Ortronics® Part Numbers, Blue
From the patch panel to the electronic equipment located within the equipment rack, cabinet or backboard	3, 5, 7 foot lengths only	OR-MC5E03-06 (3 ft) OR-MC5E05-06 (5 ft) OR-MC5E07-06 (7 ft)
From the WAO to the computer workstation	7, 9, 15 foot lengths only	OR-MC5E07-06 (7 ft) OR-MC5E09-06 (9 ft) OR-MC5E15-06 (15 ft)
Pair to Pair NEXT Loss @ 100MHz	37.2 to 38.1 dB	
Return Loss @ 100MHz	18 dB	
Active Live Channel Testing	0.17 error per minute allowable	
Preferred/Recommended Manufacturer, or equal.	Ortronics® Clarity ^{5E}	

Table 04-3 Manufactured FTTD Patch Cords Lengths/Specifications

Manufactured Patch Cords	Maximum Length/Performance	Corning Cable System® Part Numbers for Single-mode Cords
From the patch panel to the electronic equipment located within the equipment rack, cabinet or backboard	3, 5, 7 foot lengths only	040402R5120003F (3 feet) 040402R5120005F (5 feet) 040402R5120007F (7 feet)
From the WAO to the computer workstation	7, 9, 15 foot lengths only	040402R5120007F (7 feet) 040402R5120009F (9 feet) 040402R5120015F (15 feet)
Attenuation (dB/km)	1.0/.75	
Bandwidth (MHz/km)	N/A	
Preferred/Recommended Manufacturer, or equal.	Corning Cable Systems®	

Figure 04-1 Sample Labeling 24-port Patch Panel.

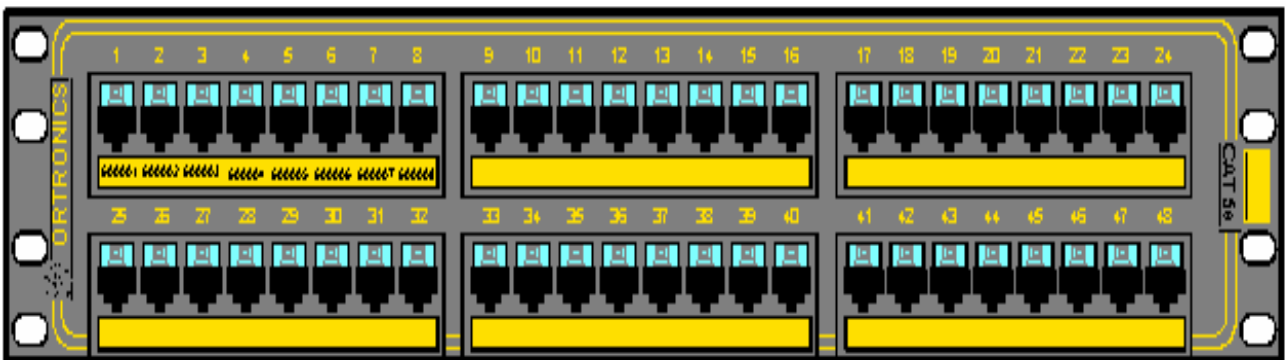
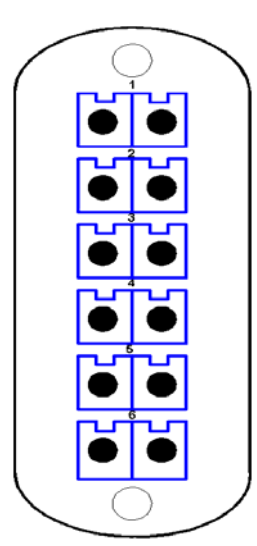
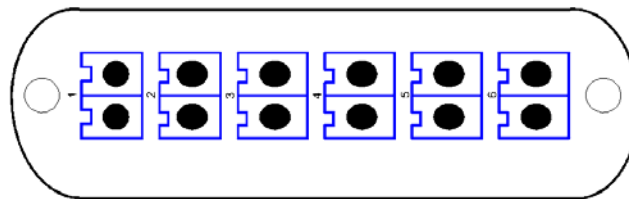

Figure 04-2 Sample Labeling FTTD Patch Panel



Vertical

CAAN: 4910*		
	Single-mode**	Single-mode**
1	F1XXXXX-01	F1XXXXX-02
2	F1XXXXX-03	F1XXXXX-04
3	F1XXXXX-05	F1XXXXX-06
4	F1XXXXX-07	F1XXXXX-08
5	F1XXXXX-09	F1XXXXX-10
6	F1XXXXX-11	F1XXXXX-12



Horizontal

CAAN: 5566***					
1	2	3	4	5	6
F1XXXXX-01	F1XXXXX-03	F1XXXXX-05	F1XXXXX-07	F1XXXXX-09	F1XXXXX-11
F1XXXXX-02	F1XXXXX-04	F1XXXXX-06	F1XXXXX-08	F1XXXXX-10	F1XXXXX-12

*Label numbering sequence for vertically mounted housing panel. Fiber ports shall be numbered consecutively.

**Yellow is Single-mode fiber strands,

*** Label numbering sequence for horizontal mounted housing panels. Fiber ports shall be numbered consecutively.

Specification 05 Indoor/Outside Plant Fiber Optic Cable Requirements

These specifications provide a minimum configuration that shall be used when planning new construction or major remodeling of an existing facility. Communications Resources shall be consulted early during the utilities planning phase of the project since each site may have technical requirements requiring a modification of these specifications.

A. Indoor/Outdoor and outside plant fiber optic cable construction specifications:

1. OSP cable shall be a dry cable with a water-swellaable tape versus a traditional gell-filled flooding compound.
2. Optical fibers shall be placed inside a standard 3.0 mm buffer tube.
3. Each buffer tube shall contain up to 12 fibers.
4. The fibers shall not adhere to the inside of the buffer tube.
5. Each fiber shall be distinguishable by means of color-coding in accordance with TIA/EIA-598-B, "Optical Fiber Cable Color Coding."
6. The fibers shall be colored with ultraviolet (UV) curable inks.
7. Buffer tubes containing fibers shall be color-coded with distinct and recognizable colors in accordance with TIA/EIA-598-B, "Optical Fiber Cable Color Coding."
8. Buffer tube colored stripes shall be inlaid in the tube by means of co-extrusion when required. The nominal stripe width shall be 1 mm.
9. For dual layer buffer tube construction cables, standard colors are used for tubes 1 through 12 and stripes are used to denote tubes 13 through 24. The color sequence applies to tubes containing fibers only and shall begin with the first tube. If fillers are required, they shall be placed in the inner layer of the cable. The tube color sequence shall start from the inside layer and progress outward.
10. In buffer tubes containing multiple fibers, the colors shall be stable across the specified storage and operating temperature range and not subject to fading or smearing onto each other or into the gel filling material. Colors shall not cause fibers to stick together.
11. The buffer tubes shall be resistant to external forces and shall meet the buffer tube cold bend and shrink back requirements of 7 CFR 1755.900.
12. Fillers may be included in the cable core to lend symmetry to the cable cross-section where needed. Fillers shall be placed so that they do not interrupt the consecutive positioning of the buffer tubes. In dual layer cables, any fillers shall be placed in the inner layer. Fillers shall be nominally 3.0 mm in outer diameter.

13. The central anti-buckling member shall consist of a dielectric, glass reinforced plastic (GRP) rod. The purpose of the central member is to prevent buckling of the cable. The GRP rod shall be over coated with a black colored thermoplastic when required to achieve dimensional sizing to accommodate buffer tubes/fillers.

14. Each buffer tube shall be filled with a non-hygroscopic, non-nutritive to fungus, electrically non-conductive, homogenous gel. The gel shall be free from dirt and foreign matter. The gel shall be readily removable with conventional nontoxic solvents.

15. Buffer tubes shall be stranded around the dielectric central member using the reverse oscillation, or "S-Z", stranding process. Water blocking yarn(s) shall be applied longitudinally along the central member during stranding.

16. Two polyester yarn binders shall be applied contra-helically with sufficient tension to secure each buffer tube layer to the dielectric central member without crushing the buffer tubes. The binders shall be non-hygroscopic, non-wicking and dielectric with low shrinkage.

17. For single layer cables, a water blocking tape shall be applied longitudinally around the outside of the stranded tubes/fillers. The tape shall be held in place by a single polyester binder yarn. The water blocking tape shall be non-nutritive to fungus, electrically non-conductive and homogenous. It shall also be free from dirt and foreign matter.

18. For dual layer cables, a second (outer) layer of buffer tubes shall be stranded over the original core to form a two-layer core. A water blocking tape shall be applied longitudinally over both the inner and outer layer with each being held in place with a single polyester binder yarn. The water blocking tape shall be non-nutritive to fungus, electrically non-conductive and homogenous. It shall also be free from dirt and foreign matter.

19. The cable shall contain at least one ripcord under the sheath for easy sheath removal of all-dielectric cable. The cable shall contain at least one ripcord under the inner sheath and under the steel armor for armored cable. The ripcord color shall be orange for non-armored sheaths and yellow for armored sheaths.

20. Dielectric yarns shall provide tensile strength.

21. The high tensile strength dielectric yarns shall be helically stranded evenly around the cable core.

22. All-dielectric cables (non-armored) shall be sheathed with medium density polyethylene (MDPE). The minimum nominal jacket thickness shall be 1.4 mm. Jacketing material shall be applied directly over the tensile strength members and water blocking tape. The polyethylene shall contain carbon black to provide ultraviolet light protection and shall not promote the growth of fungus. See Figure 05-1.

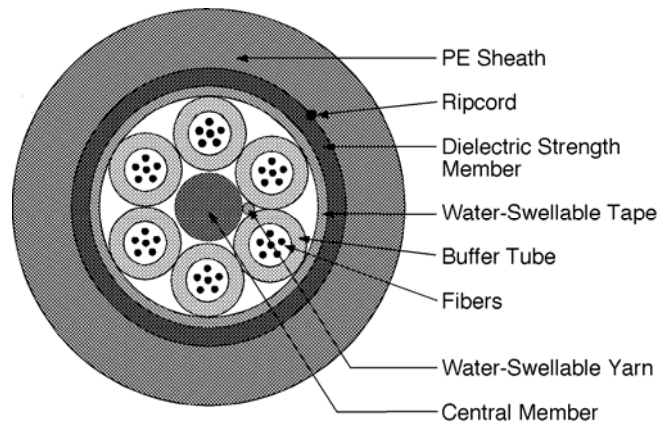
Figure 05-1 Dielectric OSP Fiber Optic Cable

23. Armored cables shall have an inner sheath of MDPE. The minimum nominal jacket thickness of the inner sheath shall be 1.0 mm. The inner jacket shall be applied directly over the tensile strength members and water blocking tape. A water blocking tape shall be applied longitudinally around the outside of the inner jacket. The armor shall be a corrugated steel tape, plastic-coated on both sides for corrosion resistance, and shall be applied around the outside of the water blocking tape with an overlapping seam with the corrugations in register. The outer jacket shall be applied over the corrugated steel tape armor. The outer jacket shall be a MDPE with a minimum nominal jacket thickness of 1.4 mm. The polyethylene shall contain carbon black to provide ultraviolet light protection and shall not promote the growth of fungus. See Figure 05-2.

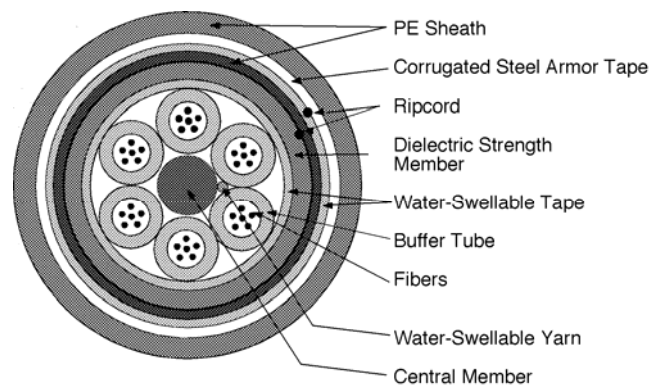
Figure 05-2 Armored OSP Fiber Optic Cable

24. The MDPE jacket material shall be as defined by ASTM D1248, Type II, Class C and Grades J4, E7 and E8.

a. The jacket or sheath shall be continuous, free from pinholes, splits, blisters or other imperfections.

b. The cable jacket shall contain no metal elements and shall be of a consistent and uniform thickness. Cable jackets extruded under high pressure are not acceptable. The jacket shall be smooth, as is consistent with the best commercial practice. The jacket shall provide the cable with a tough, flexible, protective coating able to withstand the stresses in normal installation and service.

c. Cable jackets shall be marked with manufacturer's name or file number, sequential meter or foot markings, month and year, or quarter and year of manufacture, and a telecommunications handset symbol, as required by Section 350G of the National Electrical Safety Code® (NESC®), fiber count, fiber type, flame rating (where applicable) and listing marking. The actual length of the cable shall be within $-0/+1\%$ of the length markings. The print color shall be white, with the exception that cable jackets containing one or more coextruded white stripes shall be printed in light blue. The height of the marking shall be approximately 2.5 mm.

d. The cable jacket of a cable containing two different fiber types (hybrid construction) shall be marked to indicate quantity of each fiber type, identity of each fiber type and the fiber sequence.

e. When required, cables shall be sheathed with flame-retardant polyvinyl chloride (PVC). Jacketing material shall be applied directly over the tensile strength members and water blocking tape. The PVC shall contain carbon black to provide ultraviolet light protection and shall not promote the growth of fungus.

f. When required, un-armored, all-dielectric cables shall be listed OFNR and shall be described previously.

g. When required, interlocking armored cables shall be as described previously in this section, but shall also include an interlocking aluminum armor applied helically around the outside of the cable jacket. The interlocking armor may be left un-jacketed or may have a PVC outer jacket. The color of the armor jacket (if specified) shall match the jacket color of the optical fiber cable located inside the armor. The armor for these cables shall be comparable to liquid tight flexible metal conduit if jacketed or flexible metal conduit if not jacketed. The cable used in this application shall be listed OFCR. Cables with interlocking armor shall be available in fiber counts up to 120 fibers.

h. If the initial marking fails to meet the specified requirements (i.e. improper text statement, color, legibility or print interval), the cable may be remarked using a contrasting alternate color. The numbering sequence shall differ from the previous numbering sequence, and a tag shall be attached to both the outside end of the cable and to the reel to indicate the sequence of remarking. The preferred remarking color shall be yellow, with the secondary choice being blue.

25. The maximum pulling tension shall be 2700 N (600 lbf) during installation (short term) and 890 N (200 lbf) for ALTOS® cable and 600 N (135 lbf) for FREEDM® cable, long term installed.

26. Be manufactured by a TL 9000 and ISO 9001 Certified Manufacturer.

B. Indoor/outdoor rated cable shall be installed in those locations where the indoor exposed cable distance from the entry point to the termination or splice location exceeds 50-feet.

Table 05-2 Single-mode Cable Specifications

Single-mode Fiber Optic Cable Description	Specification
Maximum Attenuation: (dB/km)	0.4 @ 1310nm
	0.3 @ 1550nm
Gigabit Ethernet Distance Guarantee: (meter)	5000 @ 1310nm
Temperatures: (Operation)	-40 to +70°C (-40 to +158°F) All Dielectric
	-40 to +70°C (-40 to +167°F) Armored
Maximum Tensile Load: Short Term	2700N (600 lbf)
Long Term:	890N (200 lbf) ALTOS® 600N (135 lbf) FREEDM®
Approvals and Listings	RUS 7 CFR 1755.900
Design and Test Criteria	ANSI/ICEA S-87-640 (ALTOS®), ANSI/ICEA S-104-696 (FREEDM®)
NEC Listing	Article 770
Preferred and Recommended Manufacturer:	Corning Cable Systems® ALTOS®, FREEDM®, or equal.

Table 05-3 Multimode Cable Specifications

Multimode Fiber Optic Cable Description	Specification
Maximum Attenuation: (dB/km)	3.5 @ 850nm
	1.0 @ 1300nm
Minimum LED Bandwidth (MHz/km)	200 @ 850nm, 500 @ 1300nm
Minimum RML Bandwidth (MHz/km)	385 @ 850nm
Gigabit Ethernet Distance Guarantee: (meter)	500 @ 850, 1000 @ 1300
Temperatures: (Operation)	-40 to +70°C (-40 to +158°F) All Dielectric
	-40 to +70°C (-40 to +167°F) Armored
Maximum Tensile Load: Short Term:	2700N (600 lbf)
	890N (200 lbf) (ALTOS®)
Long Term:	600N (135 lbf) (FREEDM®)
Approvals and Listings	RUS 7 CFR 1755.900
Design and Test Criteria	ANSI/ICEA S-87-640 (ALTOS®) ANSI/ICEA S-104-696 (FREEDM®)
Preferred and Recommended Manufacturer:	Corning Cable Systems® ALTOS®, FREEDM®, or equal.

Specification 06 OSP/Riser/Backbone Fiber Optic Patch Panel/Patch Cords

These specifications provide a minimum configuration that shall be used when planning new construction or major remodeling of an existing facility. Communications Resources shall be consulted early during the utilities planning phase of the project since each site may have technical requirements requiring a modification of these specifications.

A. Fiber Optic Connectors

1. Fiber optic cable for outside plant and riser/backbone installations shall be fusion spliced to factory made 568SC Ultra PC Polish type pigtails at the ADF/BDF/IDF:

a. Corning Cable Systems® 568SC Duplex Ceramic Ferrule, 1 meter Multimode cable assembly, or equal.

b. Corning Cable Systems® 568SC Ultra PC Polish, 1 meter Single-mode cable assembly, or equal.

B. Closet Connector and Splice Housings

1. Fiber distribution cabinets shall be wall-mounted or rack-mounted in either welded steel equipment racks or enclosed data cabinets.

2. All fiber optic connectors, termination housings and hardware shall be of the same manufacturer as the installed cable to ensure campus wide network system compatibility, optimum performance, fit, function, appearance and warranty. The preferred and recommended type and manufacturer of fiber optic connectors, termination housings and connector panels shall be Corning Cable Systems®, or equal. If substitutions are requested by the consultant/contractor, then documented and demonstrated equivalency shall be provided to CR for their review.

3. 568SC type fiber connector panels can be either Duplex 6 or 12 ports depending upon the availability of termination space within the cabinet, and shall be of the same manufacturer as the housing to ensure fit, function, appearance and warranty. Size of connector panel installed shall require the approval of Communications Resources.

4. All loose-tube outside plant fiber optic cables terminated with field installable uncam connectors shall have a buffer tube fan out kit installed prior to the installation of fiber connectors.

5. Fiber distribution cabinets (rack and wall-mounted closet connector housings) shall be labeled in accordance with Specification 09, Outside Plant and Riser Cable Labeling Requirements.

6. The fiber distribution cabinets shall be configured with jumper troughs to aid in jumper management.

7. Fiber optic cable for outside plant and riser/backbone installations shall be terminated in rack or wall mounted fiber optic termination housings:

a. Corning Cable Systems® Closet Connector and Splice Housings (CCS), Rack-mountable, or equal:

1). CCS-01U (24 fibers)

2). CCS-03U (48 fibers)

b. Corning Cable Systems® Closet Connector Housings (CCH), Rack-mountable, or equal:

1). CCH-03U (72 fibers)

2). CCH-04U (144 fibers)

c. Corning Cable Systems® Closet Splice Housings (CSH), Rack-mountable, or equal:

1). CJH-02U (96 fibers)

2). CSH-03U (288 fibers)

3). CSH-05U (528 fibers)

d. Corning Cable Systems® Wall-Mountable Closet Housing (WCH), Wall-mountable, or equal:

1). WCH-02P (24 fibers)

2). WCH-04P (48 fibers)

3). WCH-06P (72 fibers)

4). WCH-08P (96 fibers)

5). WCH-12P (144 fibers)

8. Rack-mountable Connector Housing Splice Trays, or equal:

a. M67-112 (Type 2S, 24 fusion splices)

9. Wall-mountable Closet Housing Splice Tray Holders and Splice Trays:

a. Splice Tray Holders, or equal:

1). WCH-SPLC-2P (2 trays, max 12 fusion splices)

2). WCH-SPLC-4-8 (8 trays, max 48 fusion splices)

3). WCH-SPLC-12 (12 trays, max 72 fusion splices)

b. Splice Trays, or equal:

1). M67-068 (Type 2R, 6 fusion splices)

3. Fiber optic cable for outside plant and riser/backbone installations shall be terminated on Duplex 568SC type connector panels at the ADF/BDF/IDF:

a. Corning Cable Systems®, CCH-CP06-91 (Preloaded 3 duplex connectors, Multimode, Composite Insert, Beige, for connecting 6 SC connectors), or equal.

b. Corning Cable Systems®, CCH-CP06-59 (Preloaded 3 duplex connectors, Single-mode, Ceramic Inserts, Blue for connecting 6 SC connectors), or equal.

c. Corning Cable Systems®, CCH-CP12-91 (Preloaded 6 duplex connectors, Multimode, Composite Insert, Beige, for connecting 12 SC connectors), or equal.

d. Corning Cable Systems®, CCH-CP12-59 (Preloaded 6 duplex connectors, Single-mode, Ceramic Insert, Blue, for connecting 12 SC connectors), or equal.

C. Fiber Optic Patch Cords

1. Fiber optic patch cords shall be of the manufacturer duplex type, and from the same manufacturer as the termination hardware and cable to ensure compatibility, fit, function, appearance and performance. Field fabricated patch cords **shall not** be used.

2. Proper bend radius shall be maintained at the termination and WAO locations.

3. Patch cords shall be properly labeled in accordance with UC Davis and TIA/EIA 606-A standards.

4. Ultra PC 568SC duplex type connector patch cords shall be used at the outside plant and riser cable termination locations.

Specification 07 Equipment Racks and Distribution Cabinets

These specifications provide a minimum configuration that shall be used when planning new construction or major remodeling of an existing facility. Communications Resources shall be consulted early during the utilities planning phase of the project since each site may have technical requirements requiring a modification of these specifications.

A. UC Davis utilizes seven distinct configurations of distribution equipment racks or cabinets for use in the Equipment Room/Telecommunications Room (ER/TR) (ADF/BDF/IDF): Type 1, Type 2, Type 3, Type 3A, 3B, 3L and 3R.

B. The type and use of each equipment rack or cabinet depends on the ADF/BDF/IDF location, amount of network electronics, termination hardware to be installed, number of Network Access Modules (NAM)'s they serve and the level of security of the location.

C. Table 07-1 lists the types of distribution equipment racks/cabinets and the application for each type.

Table 07-1 Distribution Equipment Rack/Cabinet Descriptions

Distribution Equipment Racks/Cabinets	Uses
Type 1	96 to 192 NAM's
Type 2	48 to 96 NAM's
Type 3	48 NAM's or less
Type 3A	48 NAM's or less (wall mounted components)
Type 3B	48 NAM's or less
Type 3L	48 NAM's or less (Lab Cabinet)
Type 3R	48 NAM's or less (Outside Plant equipment enclosure)

D. Free standing equipment racks shall be used in all ADF/BDF/IDF locations that are secured by a CR lockable door. Equipment racks shall meet the following requirements:

1. One piece 10 gauge welded steel. Nominal height is 7ft (45U). Fits 19 in. rack mount equipment. Rails must be double sided and tapped on both sides with 12-24 UNC threads in EIA Universal 5/8 – 5/8 – ½ inch vertical mounting hole pattern that matches industry standards and allows quick installation on either side of rack.

2. UL 1863 Tested / Listed to 2,500 lbs static load – max safety factor of 4 – tested to 10,000 lbs. Proof of conformance must be supplied with submittal prior to work.

3. NEBS-Telecordia GR-63-CORE Zone 4: Tested with 500 lb of equipment installed. Dynamic shaker table tested and passed. Proof of conformance must be supplied with submittal prior to work.

4. Approved and Stamped by a Certified State of California Structural Engineer to OSHPD (Office of Statewide Health Planning and Development), CBC (California

Building Code) and UBC (Uniform Building Code). Proof of conformance must be supplied with submittal prior to work.

5 EIA 310-D listed.

6. Ground holes provided in multiple locations in accordance with BICSI guidelines. Ground symbol pressed into metal as required by NEC (National Electric Code).

7. Single-sided vertical cabling management sections shall be installed with each freestanding rack. Cable management sections shall be of the same manufacturer as the free standing rack to ensure compatibility and quality.

8. Receptacles shall be located on active equipment racks 15" Above the Finished Floor (AFF). Flexible conduit shall be used to prevent the shearing of the conduit during a seismic event.

E. Free standing cabinets shall be used **only** in locations that are **not** securable by a CR lockable door or meet environmental requirements. CR shall approve these areas prior to the design or installation of these cabinets. Reference UCD Policy & Procedure Manual, Section 310-10, Telecommunications Services dated 1/15/02. Cabinets shall meet the following requirements:

1. One piece 10 guage welded steel. Nominal height is 7ft (45U). Fits 19 in. rack mount equipment. Rails must be double sided and tapped on both sides with 12-24 UNC threads in EIA Universal 5/8 – 5/8 – ½ inch vertical mounting hole pattern that matches industry standards and allows quick installation on either side of rack.

2. UL 1863 Tested / Listed to 2,500 lbs static load – max safety factor of 4 – tested to 10,000 lbs. Proof of conformance must be supplied with submittal prior to work.

3. NEBS-Telecordia GR-63-CORE Zone 4: Tested with 1000 lb of equipment installed. Dynamic shaker table tested and passed. Proof of conformance must be supplied with submittal prior to work.

4. Approved and Stamped by a Certified State of California Structural Engineer to OSHPD (Office of Statewide Health Planning and Development), CBC (California Building Code) and UBC (Uniform Building Code). Proof of conformance must be supplied with submittal prior to work.

5. EIA 310-D listed.

6. Ground holes provided in multiple locations in accordance with BICSI Standards. Ground symbol pressed into metal as required by NEC (National Electric Code).

7. Can be ganged with other 2- and 4-post racks so the sides of the frame can be opened when joined with additional enclosures.

8. Solid sides to close the end panels of single or joined enclosures. Inside panels will be removed when joining enclosures.

9. Solid top panels or top panels equipped with fans. In some cases, side-mount or top-mount air conditioning units may be required.
10. When required, top mounted fans shall provide approximately 535 CFM at 115 VAC. The fan shall include finger guards and power cord. Air filters shall be located in the doors of each unit.
11. A solid bottom panel, 16-gauge, steel plate to enclose the bottom of the cabinet and secure it.
12. The doors to be solid and hinged on the left. Two door configurations shall be hinged on their respective sides. If cabinets are located in a secure, environmentally controlled room, no doors shall be installed to allow for heat dissipation.
13. Lockable handles with a key. Keys shall be common for all cabinet types. Contact CR for key code.
14. Pre-assembled prior to delivery. The pre-assembly instructions shall include any modifications. Cabinets designed to mate with adjoining units shall be shipped as single units to facilitate transportation and movement on small elevators and in other tight quarters.
15. Extra screws and miscellaneous hardware for future maintenance requirements shall be included.
16. Each rack angle assembly shall be adjustable in depth, so that there is a minimum of 6 inches of clearance between the closed door and the face of any installed panel.
17. Cables can enter the cabinets from either the top or bottom. Provisions for cable entry knockouts are required in all designs. 2-inch trade size, T&B XTRAFLEX nonmetallic conduit, shall be used. Plastic connectors, both 90° and 45° angles for bringing cables into the cabinets shall be used. Plastic bushings shall be installed on end of conduits to protect the cable.
18. Sufficient bracing to meet or exceed Zone 4 or higher seismic requirements.
19. Color to be determined by UC Davis.
20. The cabinets shall have the dimensions listed in Table 07-2.

F. A dedicated 120V AC, 20 AMP circuit with a four-plex, NEMA 5-20R spade receptacle outlet shall be located on the backside of each rack at 15-in AFF. Two (2) dedicated 120V AC, 20 AMP circuits with a four-plex, NEMA 5-20R spade receptacle outlet shall be located in each cabinet. They will be placed on the back side of the cabinet: one at 15-inches AFF and the second near the top of the cabinet.

G. A **3-foot** working clearance shall be maintained in the front and in the rear of each equipment rack and cabinet, and a **2-foot 6-inch** working clearance shall be maintained at one end of the equipment rack or multiple rack assemblies, as a minimum. The front and rear clearance for equipment racks shall be measured from the outermost surface of the

electronic equipment and connecting hardware and **not** from the equipment rack itself since some of these devices may extend beyond the equipment rack. Clearance for cabinets shall be measured from the outermost surface of the cabinet.

Table 07-2 Equipment Rack and Cabinet Dimensions

Type of Termination	Equipment Rack Dimensions (H x W)	Distribution Cabinet Dimensions (H x W x D)
ADF	84" x 19" (3 each)	84" x 24" x 32" (3 each)
BDF	84" x 19" (3 each)	84" x 24" x 32" (3 each)
Type 1 IDF	84" x 19" (2 each)	84" x 24" x 32" (2 each)
Type 2 IDF	84" x 19" (1 each)	84" x 24" x 32" (1 each)
Type 3 IDF	28" x 19" (1 each)	
Type 3A	48" x 96" Wall-mounted Plywood Backboard Only	48" x 96" Wall-mounted Plywood Backboard Only
Type 3B		Wall-mounted Cabinet 42" x 24.2" x 9.7"
Type 3L		30" x 24" x 24" for use as a lab cabinet
Type 3R		63" x 56" x 46" outdoor enclosure

Note: Overall height of all standing equipment racks and cabinets shall not exceed 84 inches.

H. Area Distribution Frame (ADF): ADF cabinets are used only in ADF locations. Planning for a new ADF shall be coordinated with the Communications Resources, Engineering and Construction Management office.

Figure 07-1 Typical ADF Equipment

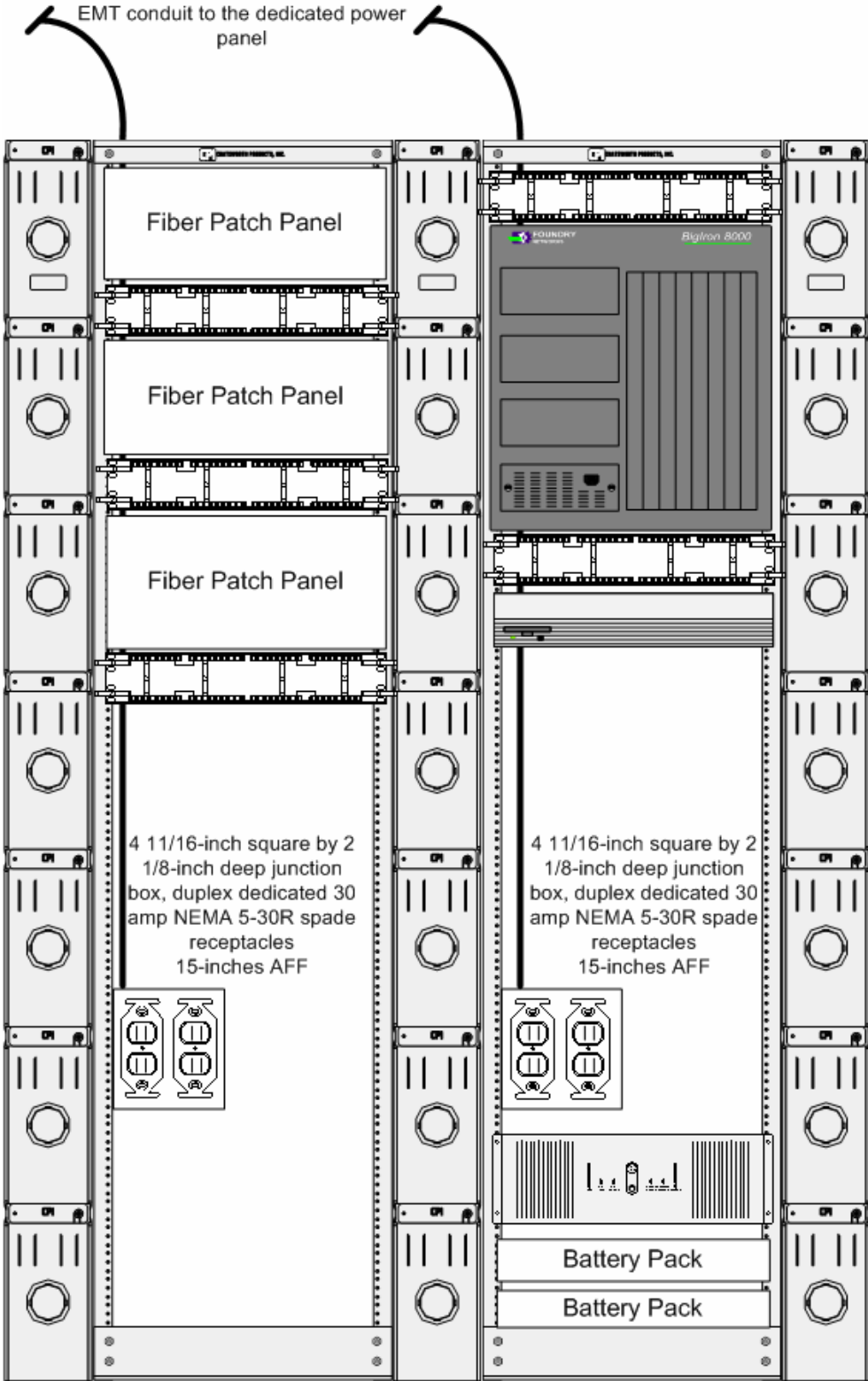

Drawing Not To Scale

Figure 07-2 Typical ADF Cabinet

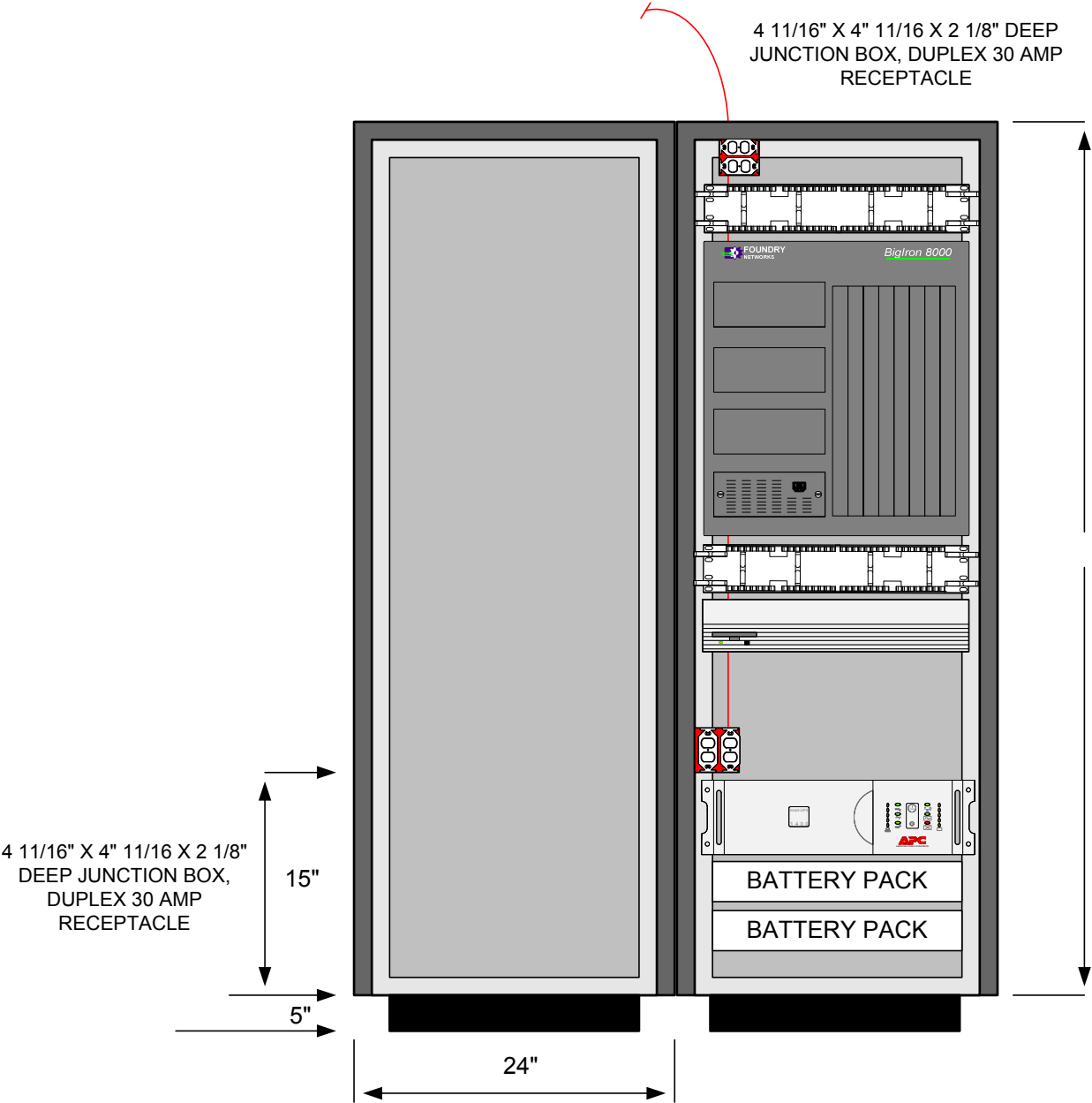
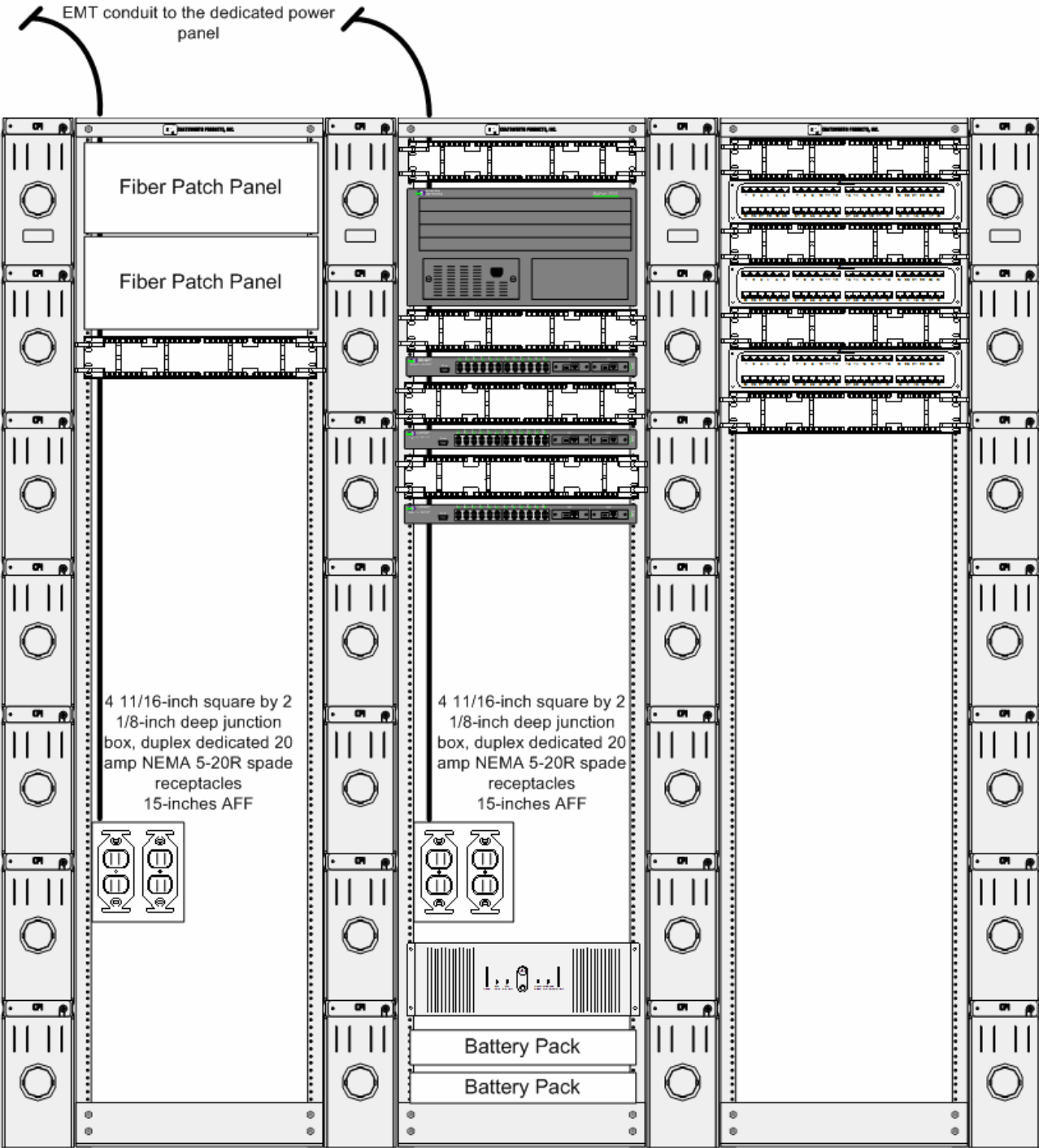
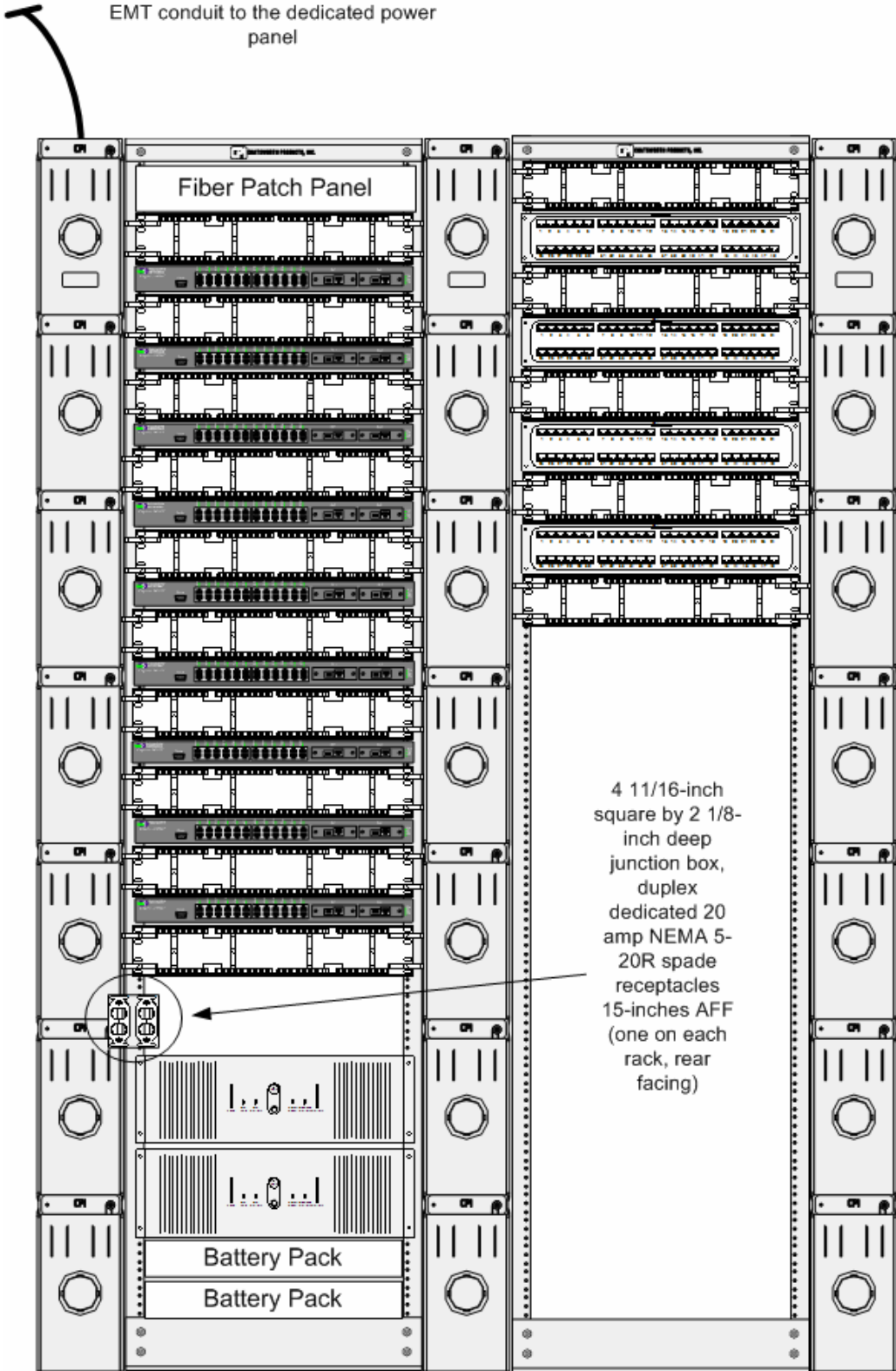

Figure 07-3 BDF/IDF Equipment Racks:



Drawing Not To Scale

Figure 07-4 Type 1 IDF Equipment Racks:



Drawing Not To Scale

Figure 07-5 Type 2 IDF Cabinet:

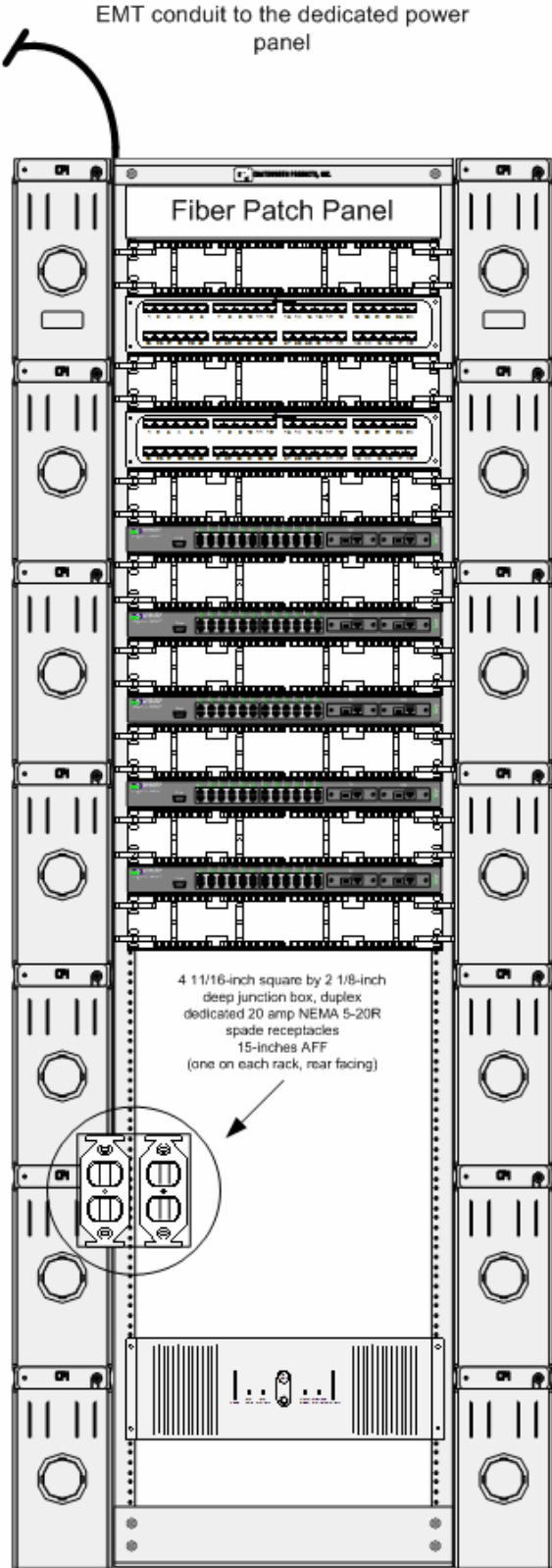

Drawing Not To Scale

I. The IDF Type 3 wall unit shall be designed to house electronic and electrical components with appropriately placed knockouts for cable entries. A design allowing for 90° pivoting shall be provided. This feature shall allow access to the rear of the enclosure for future maintenance requirements. The hinged component of the wall-mounted cabinet shall support equipment weights up to 100 pounds.

Figure 07-6 Type 3 IDF Cabinet:

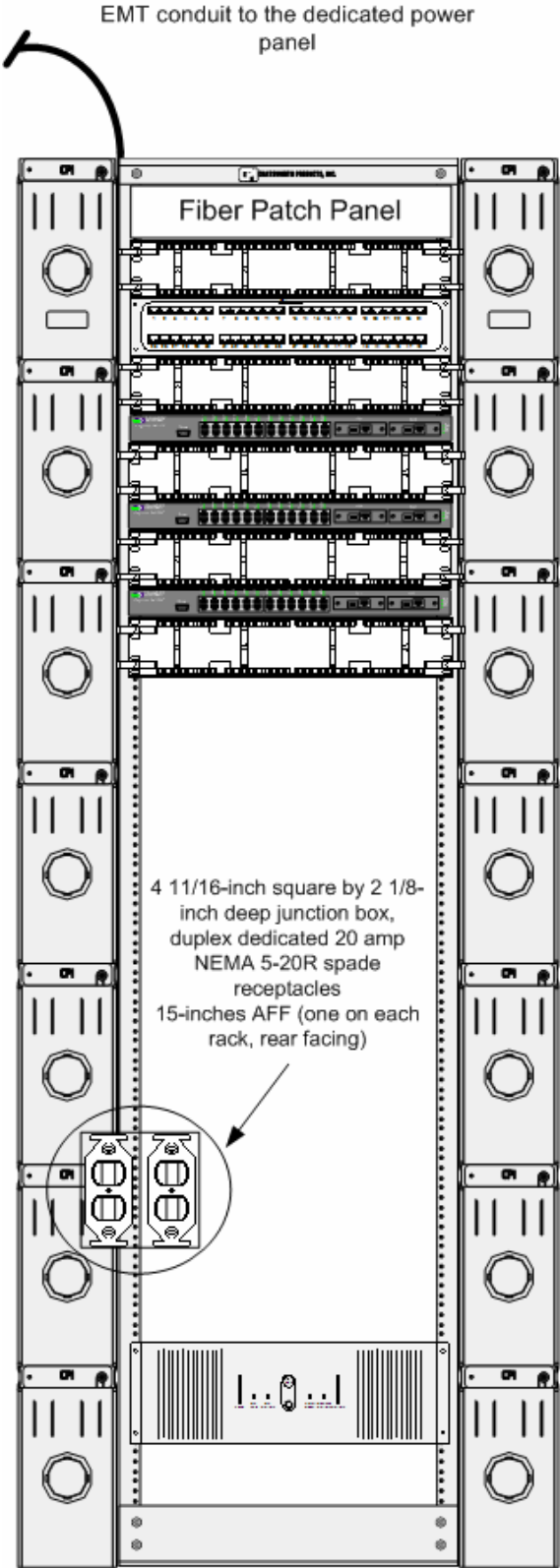

Drawing Not To Scale

Figure 07-7 Type 3 IDF Wall Mounted Cabinet:

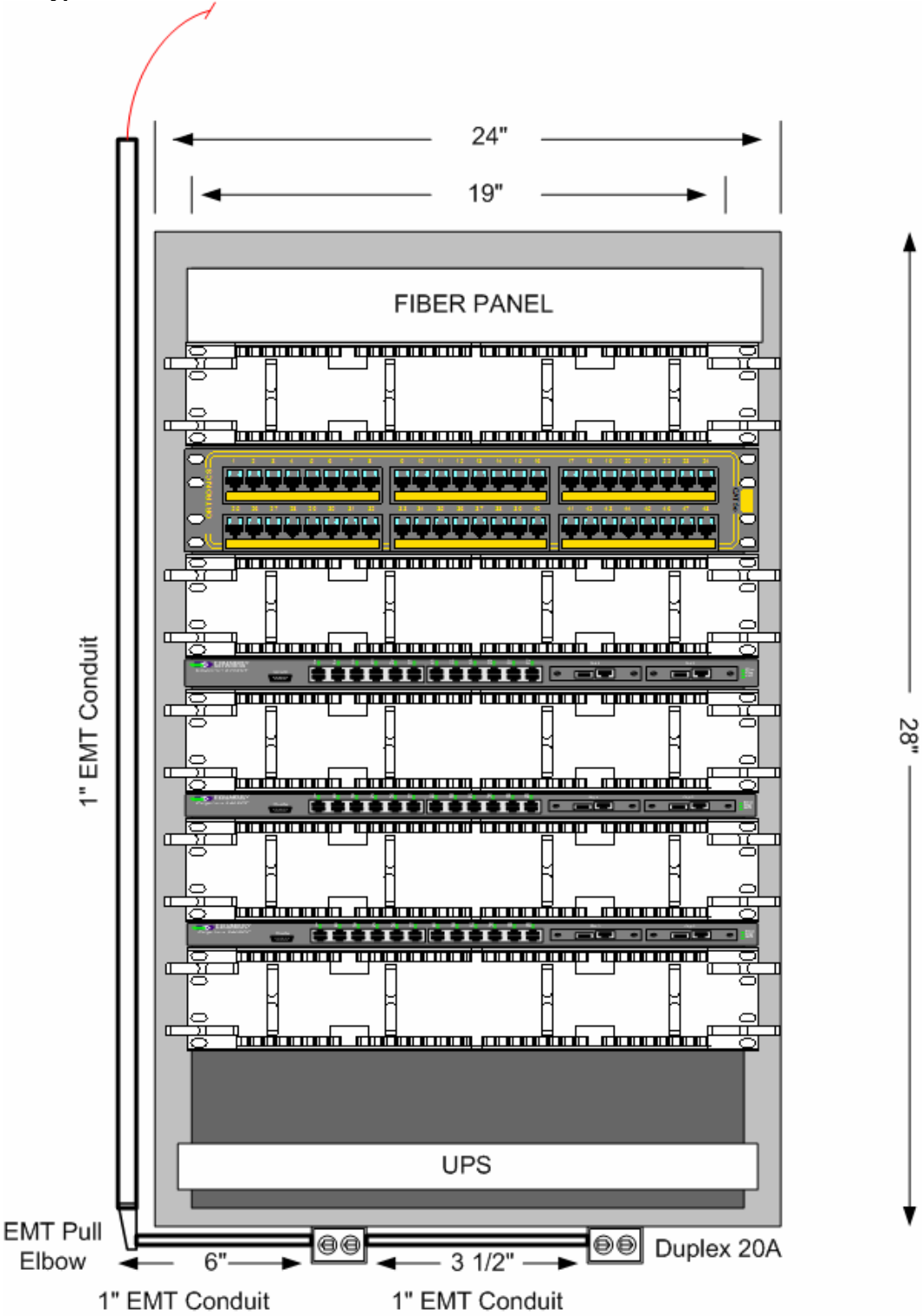

Drawing Not To Scale

J. The Type 3A is not a cabinet. It defines wall-mounted components on an approved plywood backboard, measuring 48-inches by 96-inches.

Figure 07-8 Type 3A Wall-Mounted Layout

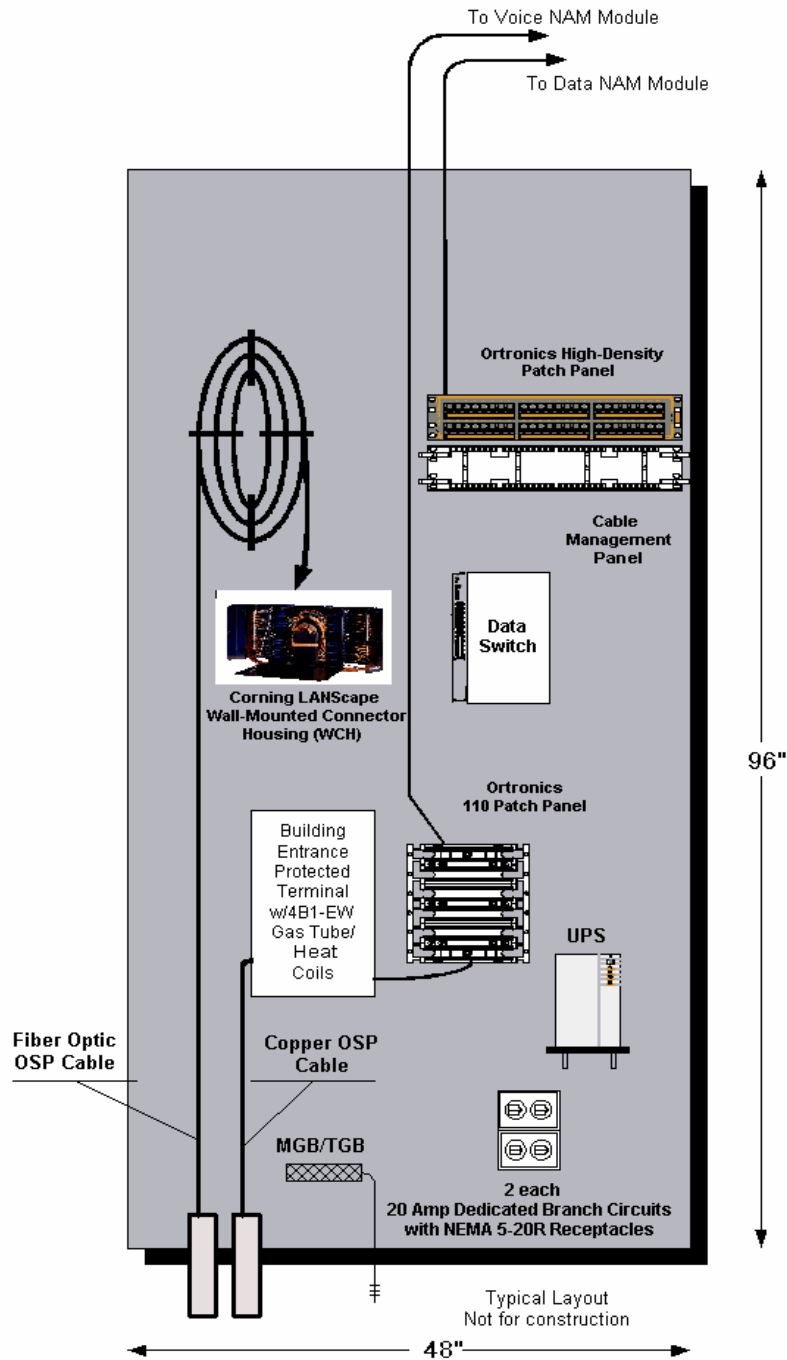

K. The Type 3B (not pictured) shall be designed for wall mounting. It is typically used in lieu of a Type 3 when 24-inches of depth are not available. It shall include its own mounting apparatus and does not require a mounting platform. The IDF Type 3B shall be designed to house electrical components with appropriately placed knockouts for cable entries. The IDF Type 3B cabinet is referred as the UCDNet2 Hubbell Remote Equipment Box 42-inch, Hubbell Premise Wiring, catalog number RE4XUCD, Middle Atlantic Products, or equal.

L. The Type 3L closet (not pictured), also referred to as the "lab cab," has the same architectural limitation imposed on all "Type 3" cabinets. The maximum number of NAM's that a "Type 3L" cabinet shall support is 48. In addition, this configuration is applied where local wiring may only extend to within the same room as the cabinet. Typical applications for this configuration are in laboratory or classroom environments where frequent local wiring changes are necessary. All "Type 3L" cabinets shall house the networking components in a cabinet structure for security and management purposes. The telecommunications space shall have a 3/4-inch plywood backboard that is at least 3-feet by 4-feet. A ground from the TMBG shall be used on all Type 3L cabinets.

M. Type 3R:

1. The Type 3R outside plant external enclosure (not pictured) is used to house telephone, data and video system patch panels and equipment. The enclosure shall be water and gas tight (when sealed) and shall be provided with a built-in heating and cooling unit to maintain consistent temperatures within the enclosure at all times.
2. The enclosure shall conform to the following specification:
 - a. The entire enclosure shall meet NEMA type 3R and 4X requirements, and constructed of steel or aluminum panels a minimum of 1/8-inch thick, powder coat painted for exposed conditions. It shall be fitted with lifting eyebolts.
 - b. The doors shall have a three point latching mechanism, external vandal resistant door handle, provision to mount padlocks and each door shall have grounding straps. All doors shall be fitted with a documentation pocket and all external doors shall have Telecordia quarter turn style door locks.
 - c. Overall dimension are not to exceed 63-inches (H) by 56-inches (W) by 46-inches (D).
 - d. Provide all mounting components and accessories and securely fix enclosure to concrete pad.
 - e. Connect built-in heating and cooling systems and power strip to electrical system. A dedicated 125VAC, 20 AMP circuit with a four-plex, NEMA 5-20R-spade receptacle shall be provided on the inside of each cabinet.
 - f. Provide strain relief and cable management inside the enclosure to ensure tidy routing of all cables.

g. The enclosure shall consist of three chambers: communications cable entry chamber, electrical chamber (including a built in heat exchanger) and communications chamber (central chamber). Each chamber shall have its own ground busbar.

Specification 08 Electrical Protections, Bonding and Grounding

These specifications provide a minimum configuration that shall be used when planning new construction or major remodeling of an existing facility. Communications Resources shall be consulted early during the utilities planning phase of the project since each site may have technical requirements requiring a modification of these specifications.

A. Electrical protection shall be provided for cables that are subject to lightning, power contact, ground potential rise or induction. The minimum protection is a tri-element gas module device.

B. Cables exposed to power sources shall be provided with sneak current protectors that shall protect cables against voltage and power surges by interrupting the current or by grounding the conductors.

C. Ground systems shall conform to the CEC and NESC specifications. Approved ground systems are:

1. Building entrance power ground from transformer – single point
2. Building steel (the metal frame of the building itself)
3. Building footing (a concrete-encased electrode near the bottom of the building's foundation).
4. Ground ring (20-feet or more of bare copper wire in direct contact with the earth). This ring normally encircles the building.
5. Metallic power service conduit, enclosure, or grounding electrode
6. Ground rod or pipe

D. Equipment single point grounds shall be grounded to the building grounding systems as defined in ANSI-J-STD-607-A Commercial Building Grounding (Earthing) and Bonding Requirements for Telecommunications.

E. Riser cables shall be grounded at the point of origination and at any floor in which pairs leave the cable sheath. Riser cable sheaths shall be bonded to approved grounds in the ER/TR (ADF/BDF/IDF)'s. Reference Figure 08-2.

F. Lateral cables shall be bonded to approved grounds in the ER/TR (ADF/BDF/IDF)'s.

G. Cable sheaths of cables entering a building shall be bonded to an approved ground at the building entrance location.

H. Protector panels shall be wired to an approved ground by the straightest and shortest means.

I. The NEC requires a listed primary protector (such as an Entrance Building Protector with 4B1E-W Protector Modules) at both ends whenever an aerial communications cable is considered exposed to accidental contact with power conductors operating at over 300 volts.

J. Exposed refers to an outdoor communications cable's susceptibility to electrical power system faults or to lightning or other transients. A cable is considered electrically exposed if any of its branches or individual circuits is exposed.

K. Reference CEC Section 800-30 for lightning exposure guidelines. In all installations, the cable shield shall be bonded to the building's ground electrode system at each end.

L. CEC Article 100 define bonding as the permanent joining of metallic parts to form an electrically conductive path that shall assure electrical continuity and the capacity to conduct safely any current that is likely to be imposed.

M. Bonding conductors are not intended to carry electrical load currents under normal conditions, but shall carry fault currents so that electrical protection (circuit breakers) shall properly operate.

N. A #6 AWG copper conductor shall be used to bond the communications components to the ground. A larger conductor shall be used if the ground source exceeds 5 ohms.

O. A Telecommunications Main Grounding Busbar (TMGB) shall be specified in the ER/TR with an approved ground connector back to the electrical service ground point.

P. Telecommunications Grounding Busbar (TGB) shall be specified for each ER/TR in the building. Each TGB shall have a #6 AWG conductor back to the TMGB.

Q. In a renovation or remodeling project where a suitable ground to the electrical service ground is not available, a grounding electrode shall be installed in accordance with the CEC Section 250-70.

R. Communications bonding relies on short direct paths that have minimum resistive and inductive impedance:

1. Bonding conductors shall be routed with minimum bends or changes in direction.
2. Bonding connections shall be made directly to the points being bonded, avoiding unnecessary connections or splices.

S. All ground attachments shall be properly tagged and labeled in accordance with TIA/EIA-606-A.

Figure 08-1 TMGB/TGB Busbar Labeling

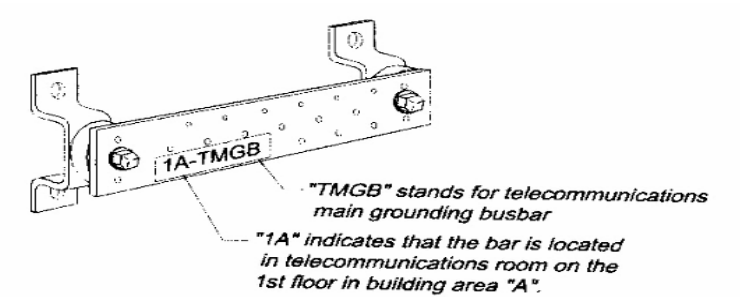
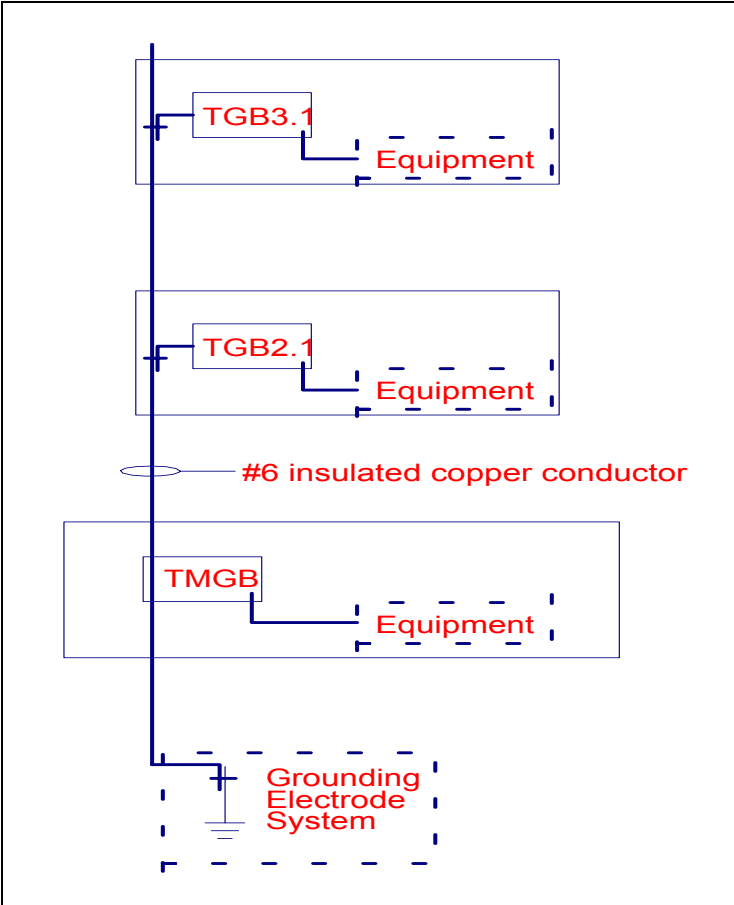

Figure 08-2 Bonding and Grounding Layout



Specification 09 Outside Plant and Riser Cable Labeling Requirements

These specifications provide a minimum configuration that shall be used when planning new construction or major remodeling of an existing facility. Communications Resources shall be consulted early during the utilities planning phase of the project since each site may have technical requirements requiring a modification of these specifications.

- A. This specification is intended to depict the installation of identification labels for outside plant/riser cable and termination equipment. Labeling materials identified in this specification are the preferred and recommended manufacturer products required for the complete identification of the installed cable systems.
- B. The intent of this labeling specification is to allow the UC Davis personnel to identify any part of the cabling system through physical identification of its components and their related components at the campus wide access points without the means of electrical, electronic or mechanical means of identification.
- C. Labeling shall meet the requirements in this document and the ANSI/TIA/EIA 606-A, Administration Standard for the Telecommunications Infrastructure of Commercial Buildings, where applicable.
- D. Fiber Optic Cable Termination Cabinet/Housing Labeling:
1. Fiber optic termination housings shall be labeled using the plastic panel provided by the termination-housing manufacturer. The plastic panel shall be overlaid with a one-piece, self- adhesive, full-size, laser printer generated label sheet adhered to the inside door of the enclosure. Contractor shall cut sheet to size. An 8.5-inch by 11-inch laser printable adhesive backed sheet, part number Avery 5165 or equal, is the preferred manufactured product. Reference Figure 09-1.
 2. The background color of the labeling sheet shall be color-coded. Single-mode labels shall be Yellow in color and multimode labels shall be Orange in color. Single-mode housing connector panels shall always be placed first and to the immediate left hand side of the housing, followed by the multimode connectors. This sequence shall apply to both single-mode and multimode strands in the same cable (Hybrid) or in separate cables. In wall-mounted housings, the single-mode connectors shall always be placed in the top position, followed by the multimode connectors. Reference Figure 09-1.
 3. Each terminal housing shall contain only one labeling sheet to identify the fiber optic strands. Multiple labels on a single door shall not be used.
 4. Labeling font shall be Helvetica, 10 point, Black in color.

5. Housing labels shall contain the Capital Asset Account Number (CAAN) for the building (Source) where the fiber optic cable originates, the CAAN for the building (Destination) where the fiber optic strands terminate and the ADF/BDF/IDF identification number where the housing is located.

6. Fiber strand numbering shall be consistent with the Consecutive Fiber Numbering (CFN) sequence as identified in TIA/EIA 568-B.1. This fiber strand numbering sequence shall be accomplished at each terminated end of the fiber optic cable. The rolling of fiber optic strands, as identified in TIA/EIA 568-B.1 as Reverse Pair Positioning (RPP) shall not be used on the UC Davis campus.

7. Fiber optic housings containing vertical connector panels shall be labeled as follows.

a. Fiber strand number 1 (Blue) shall occupy fiber port number 1 in the upper most left position of the first duplex bulkhead connector installed in the connector panel placed in the first slot on the left side of the housing.

b. Fiber strand number 2 (Orange) shall occupy fiber port number 2 of the same duplex bulkhead connector installed in the connector panel. This number 2 port is to the immediate right of fiber port number 1.

c. All remaining fiber optic strands shall be number consecutively left to right, top to bottom. Reference Figure 09-2.

8. Fiber optic housings containing horizontal connector panels shall be labeled as follows.

a. Fiber strand number 1 (Blue) shall occupy fiber port number 1 in the upper most top, left position, of the first duplex bulkhead connector installed in the connector panel placed in the upper most left slot of the housing.

b. Fiber strand number 2 (Orange) shall occupy fiber port number 2 of the same duplex bulkhead connector installed in the connector panel. This number 2 port is located immediate below fiber port number 1.

c. All remaining fiber optic strands shall be number consecutively top to bottom, left to right. Reference Figure 09-3.

E. Fiber Optic Splice Shelf Labeling:

1. Fiber optic splice shelves and drawers shall be labeled sequentially from top to bottom.

2. Identify the fiber splices using an adhesive backed, labeling stock type of paper printed on a laser printer. Trim the paper to fit the inside door of the splice housing or shelf.

3. Identify in tabular form the splice tray, position number and the fiber strand spliced at that location.

4. Labeling shall consist of the cable number, the fiber optic strand number and the strand type.

F. Fiber Optic Cable Sheath Labeling:

1. Fiber optic cables located inside buildings shall have their sheaths labeled within 12 inches of the fiber termination housing, the point at which the cable enters and/or exits the room, and at one mid-point location when the cable is installed in a cable tray or ladder, as a minimum.

2. Fiber optic cables located in maintenance holes (MH) shall have their sheaths labeled in at least one location that is visible from grade level. MH's and HH's containing splice closures shall be labeled on each side of the splice closure and shall be visible from grade level.

3. The fiber optic cable label shall consist of a plastic type tag attached with a plastic tie wrap. Plastic label shall be yellow and black in color and contain a self-laminating cover for use with pre-printed labels. Both the tag and tie wrap shall be approved for interior and exterior use. White color tie wraps shall be used indoors and black color tie wraps shall be used outdoors only. Riser rated labels and tie wraps shall be used where required. Panduit type PST-FO, self-laminating GMV4 Rigid Vinyl is the preferred manufacturer, or equal. Reference Figure 09-4.

4. All fiber optic cables shall contain a fiber optic warning tag. All warning tags shall be orange in color and contain large black letters. Tags shall be made from PVC type material and install by snapping over the cable sheath. Panduit type PCV-FOR is the preferred and recommended manufacturer, or equal. Reference Figure 09-4.

5. The fiber optic cable sheath label shall contain the cable number, cable type, total strand count of the cable, the source and destination CAAN and terminal number (ADF/BDF/IDF number), strand type and strand count, including both active and spare fiber strands. Reference Figure 09-5.

6. The fiber optic cable sheath label in maintenance that contain a splice and a change in fiber counts, shall have labels attached to each cable as shown in Figure 09-6. Each label shall contain the cable number, source NOC/MDF, CAAN or ADF identification, designation location information, fiber type, total number of fiber strands and active and spare fiber count.

G. Copper Cable Termination Housing Labeling:

1. Building entrance terminals shall be labeled with the name of the building, the building zone number, the building CAAN number, the cable pair numbers entering the terminal and the cable pair numbers exiting the terminal (if applicable). Reference Figure 09-7.

2. Terminals shall to be labeled using an electronic label maker such as the Brother P-Touch[®] and the label shall be placed on the wall above the terminal housing. The terminal housing itself shall not be labeled.

3. Labels shall be pre-printed using an electronic label maker such as the Brother P-Touch® or a laser printer. When using an electronic label maker the label shall be 18 point, “font 1” black block letters on a white background. When printing labels on a desktop printer, the size and type shall be black, Helvetica, 10 Font, block letters on a white background.

H. Copper Cable Sheath Labeling

1. Copper cables located inside buildings shall have their sheaths labeled within 12 inches of the termination housing, the point at which the cable enters and/or exits the room, and at one mid-point location when the cable is installed in a cable tray or ladder, as a minimum.

2. Copper cables located in maintenance holes (MH) and hand holes (HH) shall have their sheaths labeled in at least one location that is visible from grade level. Existing MH’s and HH’s containing splice closures shall be labeled on each side of the splice closure, and shall be visible from grade level.

3. The copper cable label shall consist of a plastic type tag attached with a plastic tie wrap. Plastic label shall be gray in color and have a write-on surface. This tag shall be approved for interior and exterior use. White color tie wraps shall be used indoors and black color tie wraps shall be used outdoors only. Riser rated labels and tie wraps shall be used where required. Panduit type CM4S-L8 is the preferred and recommended manufacturer, or equal. Reference Figure 09-8.

4. The copper cable sheath label shall contain the type of cable, cable number, cable pair count and number of dead cable pairs, if applicable. Reference Figure 09-9.

Figure 09-1 Fiber Optic Closet Connector Housing Labels

Example A: 48SM/24MM Cable from CAAN: 4021 to CAAN: 4678/ADF 7 using Figure 09-2 Vertical 568SC Duplex Closet Connector Panel

					CAAN: 4021*						
4678*	4678*	4678*	4678*	4678*	4678*	4678*	4678*	4678**	4678**	4678**	4678**
*	*	*	*	*	*	*	*	*	*	*	*
ADF 7	ADF 7	ADF 7	ADF 7	ADF 7	ADF 7	ADF 7	ADF 7	ADF 7	ADF 7	ADF 7	ADF 7
1/2	7/8	13/14	19/20	25/26	31/32	37/38	43/44	49/50	55/56	61/62	67/68
3/4	9/10	15/16	21/22	27/28	33/34	39/40	45/46	51/52	57/58	63/64	69/70
5/6	11/12	17/18	23/24	29/30	35/36	41/42	47/48	53/54	59/60	65/66	71/72

Example B: 24SM/12MM Cable from CAAN: 4021 to CAAN: 4343/BDF 0.1 and a 24SM/12MM from CAAN: 4021 to CAAN: 4910/BDF 0.1 using Figure 09-2 Vertical 568SC Duplex Closet Connector Panel

CAAN: 4021*											
4343**	4343**	4343**	4343*	4343*	4343**	4910**	4910**	4910**	4910**	4910**	4910**
BDF 0.1	BDF 0.1	BDF 0.1	BDF 0.1	BDF 0.1	BDF 0.1	BDF 0.1	BDF 0.1	BDF 0.1	BDF 0.1	BDF 0.1	BDF 0.1
1/2	7/8	13/14	19/20	25/26	31/32	1/2	7/8	13/14	19/20	25/26	31/32
3/4	9/10	15/16	21/22	27/28	33/34	3/4	9/10	15/16	21/22	27/28	33/34
5/6	11/12	17/18	23/24	29/30	35/36	5/6	11/12	17/18	23/24	29/30	35/36

Example C: 12SM/12MM Cable from CAAN: 4030 to CAAN: 4566/IDF 1.1 using Figure 09-3 Horizontal 568SC Duplex Closet Connector Panel

CAAN: 4030*					
4566**	4566**	4566**	4566**	4566**	4566**
IDF 1.1	IDF 1.1	IDF 1.1	IDF 1.1	IDF 1.1	IDF 1.1
1/2	3/4	5/6	13/14	15/16	17/18
7/8	9/10	11/12	19/20	21/22	23/24

*Source **CAAN** Number (Beginning of Fiber Strand)

Destination **CAAN Number (End Point of Fiber Strand)

AND

ADF Number (opposite terminated location of strand) (where applicable)

OR

BDF Number (opposite terminated location of strand) (where applicable)

OR

IDF Number (opposite terminated location of strand) (where applicable)

Figure 09-2 Vertical 568SC Duplex Fiber Optic Connector Panel Numbering Sequence

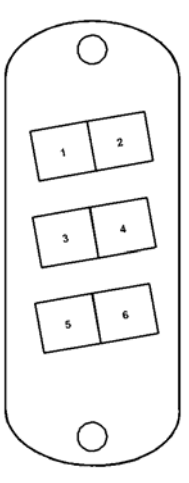

Figure 09-3 Horizontal 568SC Duplex Fiber Optic Connector Panel Numbering Sequence

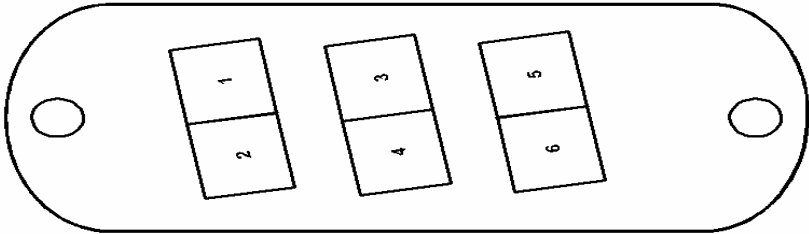

Figure 09-4 Fiber Optic Cable Sheath Labels



Figure 09-5 Fiber Optic Cable Label Sequence

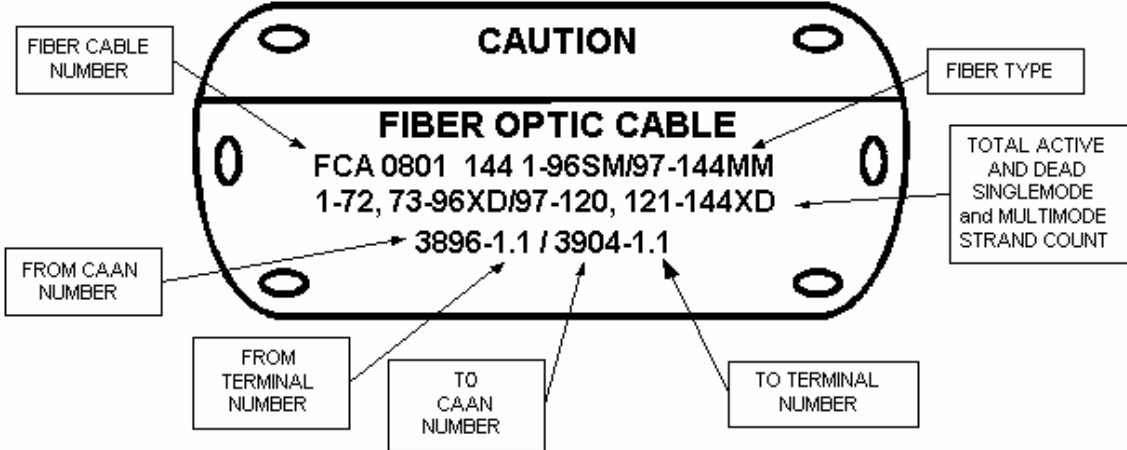

Figure 09-6 Fiber Optic Cable Label Sequence (MH/HH Splice)

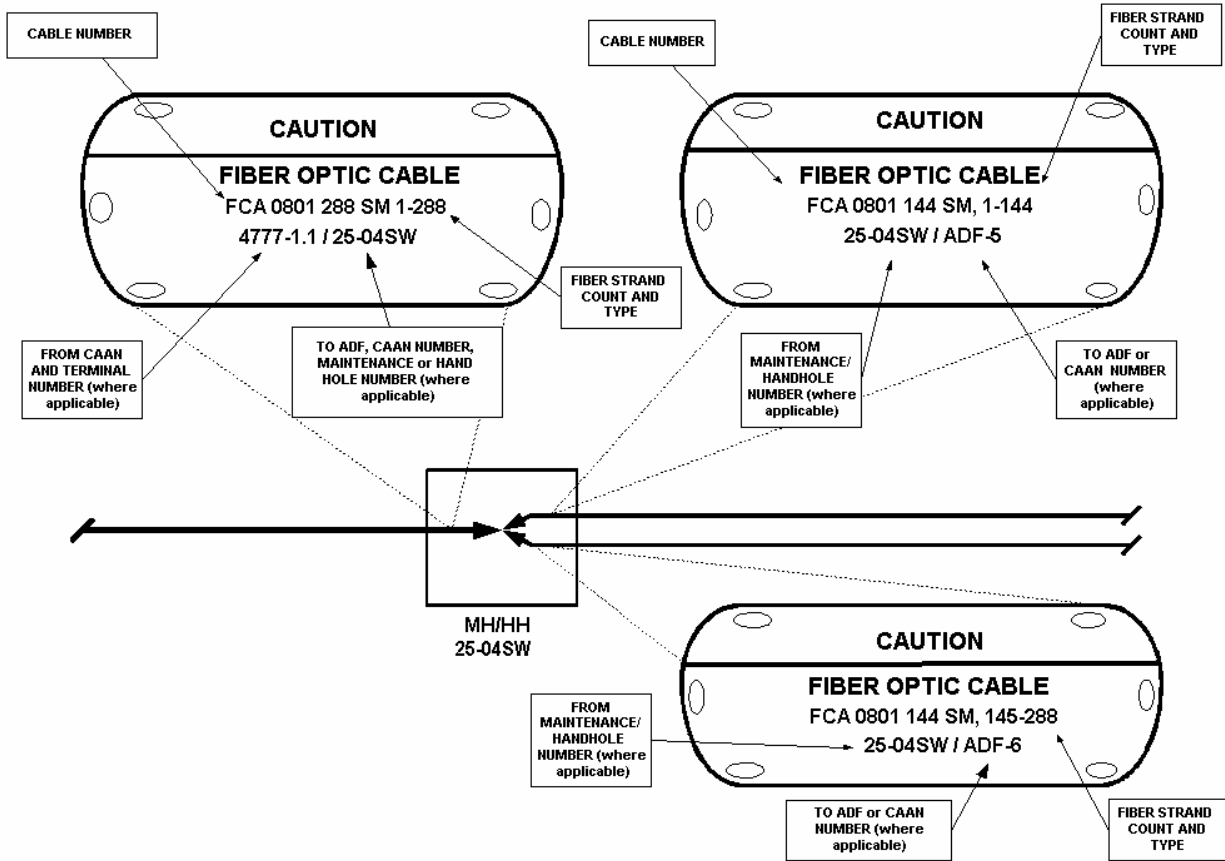

Figure 09-7 Building Entrance Terminal Label Sequence

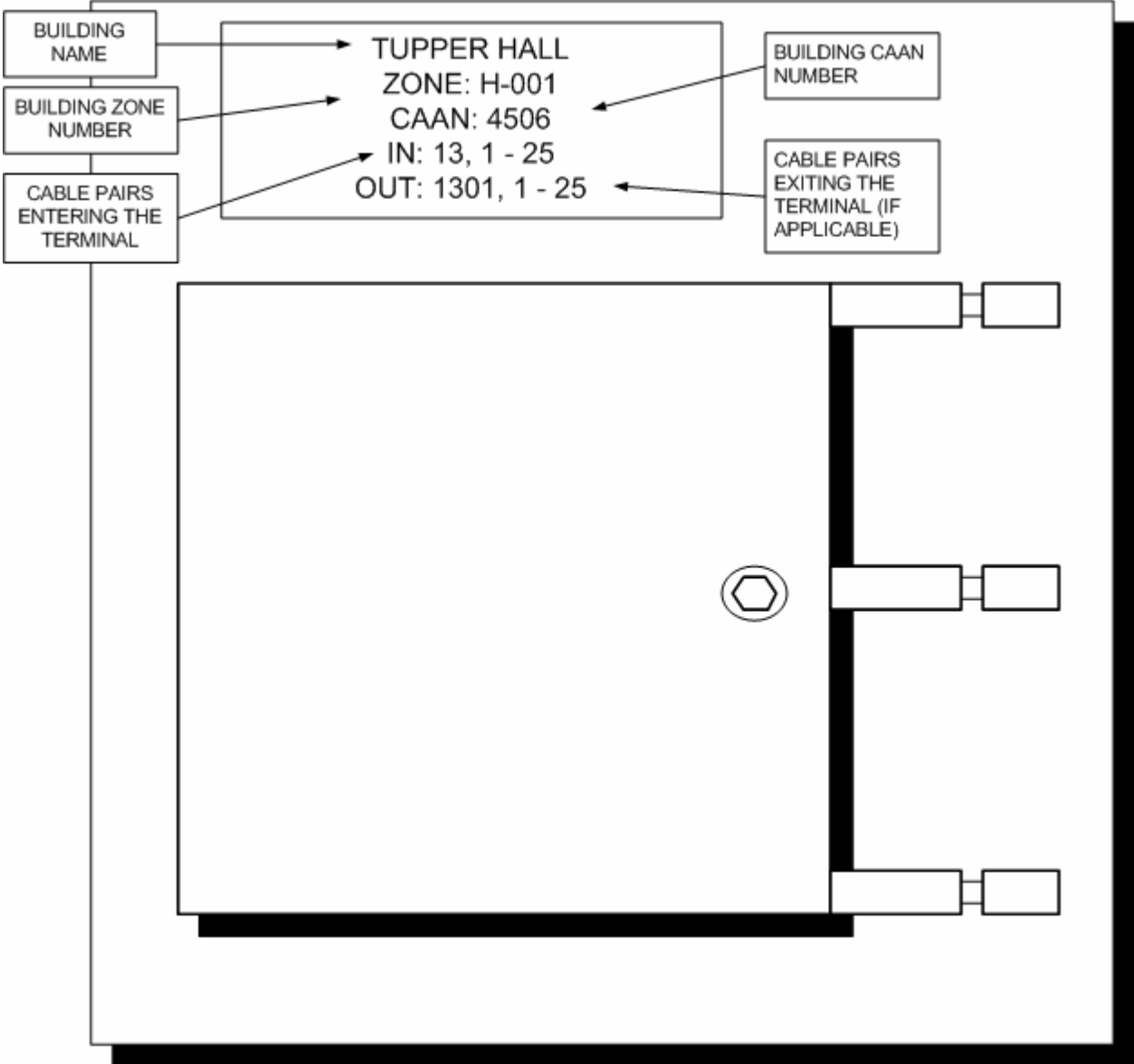
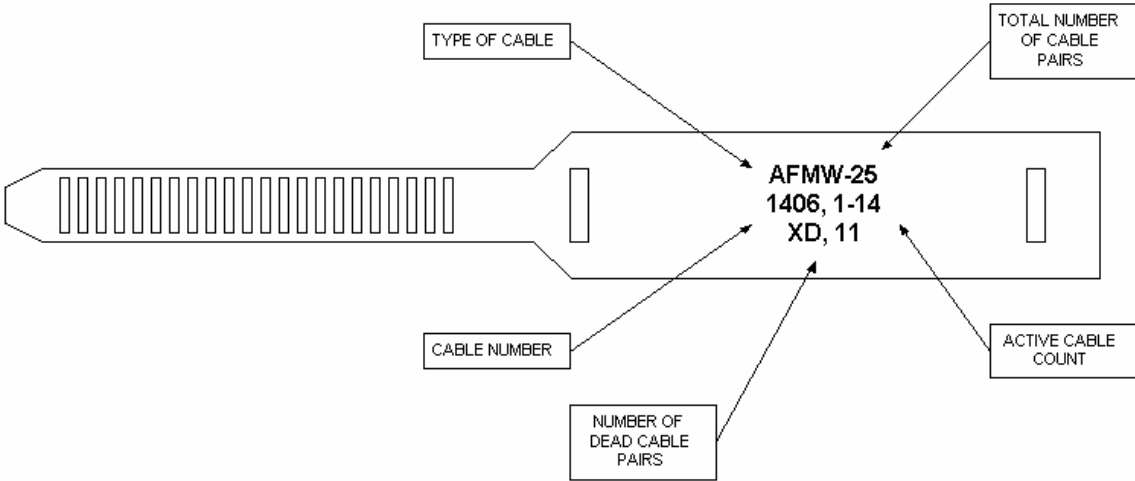

Figure 09-8 Copper Cable Sheath Labels



Figure 09-9 Copper Cable Label Sequence



APPENDIX B

Reference Materials

Following is a list of reference material on telecommunications infrastructure:

ANSI/TIA/EIA-526-7 (June 2003), Measurement of Optical Power Loss of Installed Single-mode Fiber Cable Plant. The intent of this procedure is to ensure that meaningful data describing the optical loss performance of installed single-mode cable plant can be obtained. It is not intended for component testing, nor does it define those elements of an installation that shall be measured.

ANSI/TIA/EIA-526-14A (August 2003), Optical Power Loss Measurements of Installed Multimode Fiber Cable Plant. The intent of this procedure is to ensure that meaningful data describing the optical loss performance of installed single-mode cable plant can be obtained. It is not intended for component testing, nor does it define those elements of an installation that shall be measured.

ANSI/TIA/EIA-568-B-1 (May 2001), Commercial Building Telecommunications Cabling Standard, Part 1, General Requirements provides rules and guidelines for the physical design of a cabling infrastructure that supports voice and data transmissions in a multi-product, multi-vendor environment. The standards specify a cabling system with a physical star topology. This topology provides economic benefits in terms of initial cabling costs, ongoing maintenance and administration costs. The standards specify copper and fiber optic cable by parameters that determine performance. They also identify connectors and their pin assignments to ensure inter-connectivity. The standards specify maximum allowable distances within the various elements of a cabling system.

- 568-B.1-1 Addendum 1, Minimum 4-Pair UTP and 4-Pair ScTP Patch Cable Bend Radius (August 2001)
- 568-B.1-2 Addendum 2, Ground and Bonding Specification for Screened Balance Twisted Pair Horizontal Cabling (February 2003)
- 568-B.1-3 Addendum 3, Supportable Distance and Channel Attenuation for Optical Fiber Applications by Fiber Type (February 2003)
- 568-B.1-4 Addendum 4, Recognition of Category 6 and 850nm Laser Optimized 50/125µm Multimode Optical Fiber Cabling (February 2003)
- 568-B. 1-5 Addendum 5, Telecommunications Cabling for Telecommunications Enclosures (March 2004).
- 568-B.2 Part 2: 100 Ohm Balanced Twisted Pair Cabling Components (May 2001)
- 568-B.2 Errata Changes to 568-B.2 (Not Dated)
- 568-B.2-1 Part 2: Balanced Twisted-Pair Cabling Components Addendum 1, Transmission Specification for 4-Pair 100 Ohm Category 6 Cabling (June 2002)
- 568-B.2-2-Part 2: Balanced Twisted-Pair Cabling Components Addendum 2, Balance Twisted Pair Cabling Components (December 2001)
- 568-B.2-3 Part 2: Balanced Twisted-Pair Cabling Components Addendum 3, Additional Considerations for Insertion Loss and Return Loss Pass/Fail Determination (March 2002)
- 568-B.2-4 Part 2: Balanced Twisted-Pair Cabling Components Addendum 4, Solder less Connection Reliability Requirements for Copper Connecting Hardware (June 2002)
- 568-B.2-5 Part 2: Balanced Twisted-Pair Cabling Components Addendum 5: Corrections to TIA/EIA 568-B.2 (January 2003)

- 568-B.3 Optical Fiber Cabling Components Standard (April 2000)
- 568-B.3-1 Additional Transmission Performance Guidelines for 50/125mm Optical Fiber Cabling (April 2002)

ANSI/EIA/TIA-569-B (November 2004), Commercial Building Telecommunications Pathways and Spaces, describes design and construction practices for pathways and spaces to support telecommunications media and equipment within and between buildings. Standards are for the design of horizontal and work area pathways, building entrance facilities, telecommunications closets and equipment rooms.

ANSI/TIA/EIA-570-A (October 1999), Residential Telecommunications Cabling Standard. The purpose of this document is to standardize requirements for residential telecommunications cabling. These requirements are based on the facilities that are necessary for existing and emerging telecommunications services. Within this standard, services are correlated to grades of cabling for residential units. The cabling infrastructure specifications within this standard are intended to include support for voice, data, video, multimedia, home automation systems, environmental control, security, audio, television, sensors, alarms and intercom. This standard is intended to be implemented for new construction, additions and remodeled single and multi-tenant residential buildings.

- 570-A-1 Addendum 1 - Security Cabling for Residences (March 2002)
- 570-A-2 Addendum 2 - Control Cabling for Residences (July 2002)
- 570-A-3 Addendum 3 – Whole-Home Audio Cabling for Residences (March 2002)

ANSI/TIA/EIA-587 (October 1996), Fiber Optic Graphic Symbols.

ANSI/TIA/EIA-598-B (December 2001), Optical Fiber Cable Color Coding defines the recommended identification scheme or system for individual fibers, fiber units or groups of fiber units within a cable structure. The method may be used to identify appropriate fibers for the purpose of connection or termination within a communication system or the topography of long haul, feeder route and subscriber or distribution applications for both on-premises and outside plant use.

ANSI/TIA/EIA-606-A (May 2002), Administration Standard for the Telecommunications Infrastructure of Commercial Buildings. This standard specifies administration for a generic telecommunications cabling system that will support a multi-product, multi-vendor environment. It also provides information that may be used for the design of administration products. This standard provides a uniform administration approach that is independent of applications, which may change several times throughout the life of the telecommunications infrastructure. It establishes guidelines for owners, end users, manufacturers, consultants, contractors, designers, installers and facilities administrators involved in the administration of the telecommunications infrastructure. Use of this standard is intended to increase the value of the system owner's investment in the infrastructure by reducing the labor expense of maintaining the system, by extending the useful economic life of the system and by providing effective service to users.

ANSI-J-STD-607-A (October 2002), Commercial Building Grounding (Earthing) and Bonding Requirements for Telecommunications, describes a standard method for distributing signal ground throughout a building. These standards provide the requirements for a ground reference for telecommunications systems within the telecommunications entrance facility, the telecommunications closet, and the equipment room. They also specify the requirements for bonding and connecting pathways, cable shields, conductors and hardware at telecommunications

closets, equipment rooms and entrance facilities. The grounding and bonding approach recommended in this Standard is intended to work in concert with the cabling topology as specified in ANSI/TIA/EIA-568-B.1-B.3 (Commercial Building Telecommunications Cabling Standard), pathways as specified in ANSI/TIA/EIA-569-B (Commercial Building Standard for Telecommunications Pathways and Spaces), administration as specified in ANSI/EIA/TIA-606-A (Administration Standard for the Telecommunications Infrastructure of Commercial Buildings) and customer owned outside plant as specified in TIA-758-A (Customer Owned Outside Plant). The requirements specified in this Standard, in conjunction with a basic understanding of grounding and bonding concepts and methodologies will aid the user in achieving a reliable electrical solution when applied to specific telecommunications installations.

TIA-758-A (September 2004), Customer-Owned Outside Plant Telecommunications Infrastructure Standard specifies minimum requirements for customer-owned OSP telecommunications facilities in a campus environment. The standard specifies the cabling, pathways and spaces to support the cabling. Customer-owned OSP cabling extends between separated structures including the terminating connecting hardware at or within the structures. The OSP pathway includes the pathway through the point of entry into the building space. Customer-owned OSP pathways may include aerial, direct-buried, underground (e.g., duct) and tunnel distribution techniques. Customer-owned OSP pathways and spaces specified by this standard are intended to have a useful life in excess of forty (40) years. The OSP cabling specified by this standard is intended to support a wide range of applications (e.g., voice, data, video, alarms, environmental control, security, audio, etc.) on commercial, industrial, institutional and residential sites. The customer-owned OSP cabling specified by this standard is intended to have a useful life in excess of thirty (30) years. This standard applies to all campuses, regardless of the size or population.

TIA-Telecommunications Systems Bulletin (TSB) 140 (February 2004), Additional Guidelines for Field-Testing Length, Loss and Polarity of Optical Fiber Cabling Systems. This TSB describes field-testing of length, optical attenuation and polarity in optical fiber cabling using an optical loss test set (OLTS), optical time domain reflectometer (OTDR) and a visible light source such as a visual fault locator (VFL). The purpose of this document is to clarify, not replace, ANSI/TIA/EIA-526-7 and ANSI/TIA/EIA-526-14A.

CALIFORNIA ELECTRIC CODE (CEC 2001), CODE OF REGULATIONS, TITLE 24, PART 3. This document incorporates, by adoption, the 1999 edition of the National Electrical Code® of the National Fire Protection Association with the California amendments.

CALIFORNIA BUILDING CODE (CBC 2001), CODE OF REGULATIONS, TITLE 24, PART 2, VOLUME 1 AND 2. This document incorporates, by adoption, the 1997 edition of the uniform Building Code® of the International Conference of Building Officials with necessary California amendments.

ANSI/NFPA-70: National Electrical Code® (NEC 2005). A set of codes governing items such as voltage limits, transmission media conductor size, over voltage protection requirements, fire resistance of cables and cabling methods. It is important to check with local governing bodies to determine if their codes supersede the NEC articles.

IEEE National Electrical Safety Code® (NESC 2002). This standard covers basic provisions for safeguarding of persons from hazards arising from the installation, operation or maintenance of conductors and equipment in electric supply stations and overhead and underground electric

supply and communication lines. It also includes work rules for the construction, maintenance and operation of electric supply and communication lines and equipment.

Underwriters Laboratories (UL), LAN Cable Certification Program. Test products to verify that performance meets or exceeds industry standards. The UL tests the electrical shock, flame spread and smoke production characteristics of cables. The UL also tests cables for transmission properties.

Building Industry Consulting Service International® (BICSI®) Telecommunications Distribution Methods Manual (TDMM), 10th Edition.

BICSI® Customer-Owned Outside Plant (CO-OSP) Design Manual, 3rd Edition

BICSI® Network Design Reference Manual, 5th Edition.

BICSI® Wireless Design Reference Manual, 1st Edition.

California Public Utilities Commission (CPUC) General Orders 95 and 128.

Copies of the ANSI/EIA/TIA/NESC industry standards may be purchased from Global Professional Publications, 15 Inverness Way East, Englewood, Colorado 80112- 5776, (800) 854-7179 or (714) 261-1455. <http://www.global.ihs.com/>

BICSI® TDMM, CO-OSP and Network Design Manuals can be purchased from BICSI, 8610 Hidden River Parkway, Tampa, Florida, 33637-1000, and (800) 242-7405. <http://www.bicsi.org/>

NEC book can be obtained through the National Fire Protection Association (NFPA), Batterymarch Park, Quincy, MA 02269, and (617) 770-3000. <http://www.nfpa.org/>

UL LAN Cable Certification Program publication is available from UL, Literature Stock, 333 Pfingsten Road, Northbrook, IL 60062-2096, (708) 272-8800 ext. 43731. <http://www.ul.com/lancable>

California Public Utilities Commission, 505 Van Ness Avenue, San Francisco, CA, (415) 703-1170. <http://www.cpuc.ca.gov/>

California Building Standards Commission, 2525 Natomas Park Drive, Ste. 130, Sacramento, CA. 95833-2936

Federal Aviation Administration. FCC Docket 21006—Frequency Accuracy. Washington, D.C.

Federal Communications Commission. *Code of Federal Regulations (CFR)—10CFR47, Part 76.605. Signal Quality for CATV.* Washington, D.C.

Institute of Electrical and Electronics Engineers, Inc. *Standards and Guidelines.* New York, NY.

National Fire Protection Association, Inc. *National Electrical Code®* 2002 ed. Quincy, MA.

Society for Cable Telecommunications Engineers, Inc., Exton, PA.

Society of Motion Picture and Television Engineers (SMPTE), 595 West Hartsdale Avenue, White Plains, NY. 10607

Audio Engineering Society (AES), International Headquarters, 60 East 42nd Street, Room 2520, New York, NY. 10165

Electrical Industries Association of Japan (EIAJ)

International Electrotechnical Commission (IEC), 3, rue de Varembé, P.O. Box 131, CH - 1211 GENEVA 20, Switzerland

Appendix C

Definitions

Access floor: A system consisting of completely removable and interchangeable floor panels that are supported on adjustable pedestals or stringers (or both) to allow access to the area beneath.

Administration: The method for labeling, identification, documentation and usage needed to implement moves, additions and changes of the telecommunications infrastructure.

Aerial cable: Telecommunications cable installed on aerial supporting structures such as poles, sides of buildings and other structures.

Alternate entrance: A supplementary entrance facility into a building using a different routing to provide diversity of service and for assurance of service continuity.

Architectural assemblies: Walls, partitions or other barriers that are not load bearing.

Architectural structures: Walls, floors, floor/ceilings and roof/ceilings that are load bearing.

Area Distribution Frame (ADF): A Telecommunications Space (Equipment or Telecommunications Room) that houses digital loop carrier, network switching and video electronic equipment, as well as, outside plant cable termination hardware for a specific serving area on the UC Davis campus.

Backbone: A-facility (e.g., pathway, cable or conductors) between telecommunications closets or floor.

Barriers (Architectural): Architectural structures or assemblies.

Bonding: The permanent joining of metallic parts to form an electrically conductive path that will ensure electrical continuity and the capacity to conduct safely any current likely to be imposed. (TIA)

Building core: A three-dimensional space permeating one or more floors of the building and used for the extension and distribution of utility services (e.g., elevators, washrooms, stairwells, mechanical and electrical systems and telecommunications) throughout the building.

Building Distribution Frame (BDF): A Telecommunications Space (Equipment or Telecommunications Room) that houses digital loop carrier, network switching, video electronic equipment, outside plant, riser and horizontal cable termination hardware for the building in which the BDF room is located. In addition, a BDF may also serve a number of smaller Intermediate Distribution Frames (IDF's) located within the same building and/or IDF's located outside of the building and within the immediate area on the UC Davis campus.

Buried cable: A cable installed under the surface of the ground in such a manner that it cannot be removed without disturbing the soil.

Cabinet (telecommunications): A container that may enclose connection devices, terminations, apparatus, wiring and equipment. (TIA)

Cable: An assembly of one or more conductors or optical fibers, within an enveloping sheath, constructed so as to permit use of the conductors singly or in groups.

Cabling: A combination of all cables, wire, cords and connecting hardware.

Campus: The buildings and grounds having legal contiguous interconnection.

Ceiling distribution system: A distribution system that utilizes the space between a suspended or false ceiling and the structural surface above.

Closet (telecommunications): A recognized location of the cross-connect between the backbone and horizontal facilities. This term has been replaced with the term Telecommunications Room

Conduit: A raceway of circular cross-section.

Connecting hardware: A device providing mechanical cable terminations.

Consolidation point: A location for interconnection between horizontal cables extending from building pathways and horizontal cables extending into furniture pathways.

Core area: See building core,

Cross-connect: A frame or space that enables the termination of cable elements and their interconnection or cross-connection of these cable elements, or both, by the use of a patch cord or jumper.

Cross-connection: A connection scheme between cable runs, subsystems and equipment using patch cords or jumpers to attach to connecting hardware on each end.

Device (as related to a work area): An item such as a telephone, personal computer or a graphic or video terminal.

Distribution frame: A structure with terminations for connecting the cabling of a facility in such a manner that interconnections or cross-connections may be readily made.

- a) Main – when the structure is located at the entrance facility or main cross-connect and serves the building or campus.
- b) Intermediate – when the structure is located between the main cross-connect and the telecommunications room.

Distribution terminals: the entrance facilities and the equipment rooms within or between buildings.

Emergency power: A stand-alone secondary electrical supply source not dependent upon the primary electrical source.

End user: The owner or user of the premises cabling system.

Entrance point (telecommunications): The point of emergence of telecommunications conductors through an exterior wall, a concrete floor slab or from a rigid metal conduit or intermediate metal conduit.

Entrance room or space (telecommunications): A space, wall or location in which public and private service cables, to include antennae, enter a building and continue to the equipment or telecommunications room or space.

NOTE – An entrance room or space may also serve as an equipment or telecommunications room.

Equipment room (telecommunications): A centralized space for telecommunications equipment that serves the occupants of the building.

False ceiling: See suspended ceiling.

Fire stop: A material, device, or assembly of parts installed in a cable pathway at a fire-rated wall or floor to prevent passage of flame, smoke or gases through the rated barrier (e.g., between cubicles or separated rooms or spaces), fire stop seals: See fire stop system.

Fire stop system: A specific construction consisting of the material(s) (fire stop penetration seals) that fill the opening in the wall or floor assembly and any items that penetrate the wall or floor, such as cables, cable trays, conduit, ducts, pipes and any termination devices, such as electrical outlet boxes, along with their means of support.

Fire stopping: The process of installing specialty materials into penetrations in fire-rated barriers to reestablish the integrity of the barrier.

Floor slab: That part of a reinforced concrete floor which is carried on beams below,

Furniture cluster: A contiguous group of work areas, typically including space divisions, work surfaces, storage and seating.

Ground: A conducting connection, whether intentional or accidental, between an electrical circuit (e.g., telecommunications) or equipment and the earth or to some conducting body that serves in place of earth.

Grounding conductor: A conductor used to connect the grounding electrode to the building's main grounding bus bar.

Grounding electrode: A conductor, usually a rod, pipe or plate (or group of conductors) in direct contact with the earth for the purpose of providing a low-impedance connection to the earth.

Hand hole: A structure similar to a small maintenance hole in which it is expected that a person cannot enter to perform work.

Header duct; trench, feeder duct: A raceway of rectangular cross-section placed within the floor to tie distribution duct(s) or cell@) to the telecommunications closet.

Home runs: A pathway or cable between two locations without a point of access in between.

Horizontal cabling: The cabling between and including the telecommunications outlet/connector and the horizontal cross-connect.

Hybrid cable: An assembly of two or more cables, of the same or different types or categories, covered by one overall sheath.

Infrastructure (telecommunications): A collection of those telecommunications components, excluding equipment, that together provides the basic support for the distribution of all information within a building or campus.

Innerduct: Typically, a nonmetallic pathway within a pathway. Also known as sub duct.

Insert: An opening into the distribution duct or cell, from which the wires or cables emerge.

Interconnection: A connection scheme that employs connecting hardware for the direct connection of a cable to another cable without a patch cord or jumper.

Intermediate cross-connect: A cross-connect between first level and second level backbone cabling.

Intermediate Distribution Frame (IDF): A Telecommunications Space (Telecommunications Room) that houses network switching and video electronic equipment, as well as, outside plant, riser and horizontal cable termination hardware for the building in which the IDF room is located on the UC Davis campus.

Jumper: An assembly of twisted pairs without connectors, used to join telecommunications circuits/links at the cross-connect.

Main cross-connect: A cross-connect for first level backbone cables, entrance cables and equipment cables.

Main distribution frame: See distribution frame.

Main terminal room: The location of the cross-connect point of incoming cables from the telecommunications external network and the premises cable system.

Maintenance hole (telecommunications): A vault located in the ground or earth as part of an underground duct system and used to facilitate placing, connectorization and maintenance of cables, as well as the placing of associated equipment, in which it is expected that a person will enter to perform work. NOTE – This term has replaced the term “manhole”.

Media, telecommunications: Wire, cable or conductors used for telecommunications.

Membrane penetration: An opening through only one surface or side of the barrier. Monolithic pour: The single, continuous pouring of a concrete floor and columns of any given floor of a building structure.

Minimum Point of Entry (MPOE) The MPOE is the point at which the network facilities provided by the service provider or utility stop, and the property owner's facilities begin. It also referred to as the Minimum Point of Presence (MPOP).

Multi-user telecommunications outlet assembly (MUTOA): A grouping in one location of several telecommunications work area outlets.

Network Access Modules (NAM): A UC Davis term to identify a voice, data, FTTH and/or video jack or module.

Open office: A floor space division provided by furniture, moveable partitions or other means instead of by building walls.

Optical fiber cable: An assembly consisting of one or more optical fibers.

Outlet box (telecommunications): A metallic or nonmetallic box mounted within a wall, floor or ceiling and used to hold telecommunications outlets/connectors or transition devices.

Outlet/connector (telecommunications): A connecting device in the work area, on which horizontal cable terminates. Also see NAM.

Patch cord: A length of cable with connectors on one or both ends used to join telecommunications circuits at the cross-connect.

Pathway: A facility for the placement of telecommunications cable.

Penetration: An opening in a fire-rated barrier.

Plenum: A compartment or chamber to which one or more air ducts are connected and that forms part of the air distribution system.

Poke-thru system: Penetrations through the fire resistive floor structure to permit the installation of horizontal telecommunications cables.

Pull cord or pull wire: A cord or wire placed within a raceway and used to pull wire and cable through the raceway.

Raceway: Any enclosed channel designed-for holding wires or cables.

Service entrance: See entrance facility (telecommunications).

Service equipment (power): The necessary equipment, usually consisting of a circuit breaker or switch and fuses, and their accessories, located near the point of entrance of supply conductors to a building or other structure (or an otherwise defined area) and intended to constitute the **main** control and means of cutoff of the (electrical) supply.

Sheath: See cable sheath.

Slab on grade: Concrete floor placed directly on soil, without basement or crawlspace.

Sleeve: An opening, usually circular, through the wall, ceiling or floor to allow the passage of cables.

Slot: An opening through a wall, floor, or ceiling, usually rectangular, to allow the passage of cables.

Space (telecommunications): An area used for housing the installation and termination of telecommunications equipment and cable, e.g., equipment and telecommunications room, work areas and maintenance holes/hand holes.

Splice: A joining of conductors, generally meant to be permanent, generally from separate sheaths.

Splice box: A box, located in a pathway run, intended to house a cable splice.

Suspended ceiling: A ceiling that creates an area or space between ceiling material and the structure above.

Telecommunications: Any transmission, emission, and reception of signs, signals, writings, images, and sounds, that is information of any nature by cable, radio, optical or other electromagnetic systems,

Telecommunications room/closet: See closet (telecommunications).

Telecommunications entrance facility: See entrance facility (telecommunications).

Telecommunications equipment room: See equipment room (telecommunications).

Telecommunications infrastructure: See infrastructure (telecommunications).

Telecommunications media: See media (telecommunications),

Telecommunications outlet: See outlet connector and work area outlet (WAO).

Telecommunications service entrance: See entrance facility (telecommunications).

Telecommunications space: See space (telecommunications).

Terminal:

- a) A point at which information may enter or leave a communications network.
- b) The input-output associated equipment.
- c) A device by means of which wires may be connected to each other.

Termination hardware: This term is outmoded. See connecting hardware.

Through penetration: A continuous opening that passes through both surfaces of a fire-rated barrier.

Topology: The physical or logical arrangement of a telecommunications system.

Tunnel: An enclosed passageway usually placed between buildings, for use by people, the distribution of utility services or both.

Under floor raceway: A pathway placed within the floor and from which wires and cables emerge to a specific floor area.

Usable floor space: Floor space, which is capable of being used as a work area.

Utility column: An enclosure pathway extending from the ceiling to furniture or to the floor, which forms a pathway for electrical wiring, telecommunications cable or both.

Work Area Outlet (WAO): A wall-mounted or surface-mounted faceplate or box containing a voice, data, FTTD and/or video NAM or any combination thereof.

Abbreviations

A or AMP	ampere
ac	alternating current
ADA	Americans with Disabilities Act
ADF	Area Distribution Frame
A&E	Architects & Engineers
AFF	above finished floor
AHJ	authority having jurisdiction
AHU	air handling unit
AIA	American Institute of A&Es
ALPETH	aluminum polyethylene
AMEP	Architectural, mechanical, electrical, and plumbing
ANSI	American National Standards Institute
AP	access point
AP	access provider
ASTM	American Society for Testing and Materials
AWG	American wire gauge
B or Bur	buried
BACnet	Building Automation and Control network
BAS	building automation systems
BC	bonding conductor
BD	building distributor
BDF	Building Distribution Frame
BEF	building entrance facility
BER	bit error rate
BICSI ®	Building Industry Consulting Service International
bit	binary digit
BMS	building management system
b/s	bit per second
Btu	British thermal unit
CA	cable
CAD	computer- aided design
CAM	computer- aided manufacturing
CATV	community antenna television (cable television)
CB	conduit bank
CBC	coupled bonding conductor
CBC®	California Building Code
CEC®	California Electrical Code
CCTV	closed circuit television
CD	construction documents
CEV	controlled environment vault
CF	cellular floor
ckt	circuit
CL	closet
CLEC	competitive local exchange carrier
CM	construction manager
CMP	communications plenum cable
CMR	communications riser cable

CO	central office
coax	coaxial cable
CP	consolidation point
CPE	customer premises equipment
CPE	customer provided equipment
CPVC	chlorinated polyvinyl chloride
CSI	Construction Specifications Institute
CT	cable tray
DB	direct- buried
DB	ductbank
DCE	data circuit- terminating equipment
DD	design development
DL	ductliner (innerduct)
DP	demarcation point
DTE	data terminal equipment
EF	entrance facility
EIA	Electronic Industries Alliance
EIB	European installation bus
EM	electromagnetic
EMI	electromagnetic interference
EMS	energy management system
EMT	electrical metallic tubing
ENT	electrical non-metallic tubing
EP	entrance point
ER	equipment room
e/w	equipped with
°F	degree Fahrenheit
FA	fire alarm
FACP	fire alarm control panel
FDR	feeder
FEP	fluorinated ethylene propylene
FEXT	far-end crosstalk
FPN	fine print note
ga	gauge
Gb/s	gigabit per second
GIS	geographic information system
gnd	ground
GPS	global positioning system
GRI	graded refraction index
h	hour
H	horizontal
HC	horizontal cross-connect
HH	handhole
HVAC	heating, ventilating, and air-conditioning
Hz	hertz

IC	intermediate cross-connect
ID	inside diameter
IDC	insulation displacement connector
IDF	Intermediate Distribution Frame
IEEE ®	Institute of Electrical and Electronics Engineers, Inc.
IG	isolated ground
IR	infrared
ISP	inside plant
IXC	interexchange common carrier
kb	kilobit
kb/s	kilobit per second
kHz	kilohertz
km	kilometer
KTS	key telephone system
kW	kilowatt
kWh	kilowatt hour
LAN	local area network
lbf	pound-force
LEC	local exchange carrier (now service provider [SP])
MAC	move, add, or change
MB	megabyte
Mb/s	megabit per second
MC	main cross- connect
MDF	main distribution frame
MH	maintenance hole
MHz	megahertz
MM	multimode
MUTO	multi-user telecommunications outlet
MUTOA	multi-user telecommunications outlet assembly
N	newton
NAM	Network Access Module
NEC ®	National Electrical Code ®
NEMA ®	National Electrical Manufacturers Association ®
NFPA ®	National Fire Protection Association ®
NIC	network interface card
NRTL	national recognized testing laboratory
OC	outlet cable
OD	outside diameter
Ohm	Ω
OSP	outside plant
OTDR	optical time domain reflectometer
PB	pull box
PBX	private branch exchange
PE	polyethylene
POTS	plain old telephone service (colloquial)

PP	polypropylene
pr	pair
PSTN	public switched telephone network
PVC	polyvinyl chloride
RCDD ®	Registered Communications Distribution Designer
RUS	Rural Utilities Services
RFI	request for information
RFP	request for proposal
RFQ	request for quote
RMS	rack mounting space
RNC	rigid non-metallic cable
ScTP	screened twisted- pair
SD	schematic design
SFF	small form factor
SHF	super high frequency
SL	sleeve
SM	single-mode
ST	slot
STALPETH	steel, aluminum, polyethylene
STP	shielded twisted- pair
TB	terminal block
TBB	telecommunications bonding backbone
TBBIBC	telecommunications bonding backbone interconnecting bonding conductor
TC	telecommunications closet (see telecommunications room)
T&C	terms and conditions
TDD	telecommunications device for the deaf
TEF	telecommunications entrance facility
TEL	telephone
TELCO	telephone company
TERM	terminal or terminating
TGB	telecommunications grounding busbar
TIA	Telecommunications Industry Association
TMGB	telecommunications main grounding busbar
TR	telecommunications room
TT	telephone terminal
TTB	telephone terminal board
TTY	teletypewriter/text telephone
UBC	uniform building code
UG	underground
UL ®	Underwriters Laboratories Inc. ®
UPS	uninterruptible power supply
V	vertical
WA	work area
WAN	wide area network

WAO work area outlet
WW wireway

APPENDIX D

UC Davis Policy and Procedure Manual

UCD POLICY & PROCEDURE MANUAL

Section 310-10, Telecommunications Services 1/15/02

I. PURPOSE

This section describes policies regarding campus telecommunications networks and services. The policy expands upon [Section 310-16](#) to provide specific guidance associated with use of the telecommunications resources provided by UC Davis. Information regarding services obtained through the UC Davis Health System (UCDHS) Telecommunications Department is available in [UCDHS Hospital Policies & Procedures Manual Section 1368](#).

II. DEFINITIONS

A. Distribution rooms--physical locations in buildings, usually a room, where centralized distribution frames are located.

B. Infrastructure--the aggregation of all key components needed for a functioning telecommunications/networking system. Infrastructure includes physical facilities: underground conduit, utility vaults, cables, building pathways, towers and antennas; electronics: routers, aggregators, repeaters, switches and other devices that control transmission paths; and software used to send, receive and manage the transmitted signals.

C. Telecommunications--all forms of distance communication, including data, voice, video and radio.

D. Telecommunications services--services provided to the campus by the Communications Resources (CR) Office, including, but not limited to:

1. Engineering, design, capital planning, installation, maintenance, operations, repair, consultation, training, billing and coordination functions related to the telecommunications system, including land-based and wireless voice and data services, 800 MHz emergency radio system, modems and campus and residential hall video distribution systems in compliance with regulatory requirements.

2. Local and long-distance access.

3. Access to high bandwidth advanced services networks such as Calren2 and Abilene as well as to the commercial Internet.

4. Technical support in isolating and mitigating security breaches to the campus network in accordance with the campus network security policy. CR also provides some level of monitoring to proactively detect potential intrusions.

5. Preparation of applications for initial licenses and renewal of existing licenses held by The Regents of the University of California for radio, television and microwave systems.

6. Provision of courtesy telephones for dialing on campus and to UCDHS, elevator phones and pay phones.

7. Management control of all inside and outside communications cables, ducts, frames and distribution closets.

8. Cable locator services for campus construction.
9. Administration of the reuse or removal of old outside and inside cable plant.
10. Telecommunications support and services for campus departments on a fee-for-service basis.

III. POLICY

A. General

1. UCD respects the privacy of electronic communications while seeking to ensure that UCD administrative records are accessible for the conduct of the University's business. [Section 310-16](#) provides policies and procedures for accessing an individual's records, with or without the individual's consent.
2. In compliance with Federal law, audio or video telephone conversations shall not be recorded or monitored without advising the participants unless a court has explicitly approved such monitoring or recording.
 - a. UCD Emergency Services shall record 911-type emergency calls in accordance with Federal and State laws and regulations.
 - b. Participants shall be informed when a call is being monitored or recorded for the purpose of evaluating customer service, assessing workload, or other business purpose permitted by law. UCD units that monitor or record telephone calls shall provide an alternative method of doing business with the University to clients who do not wish to be part of a monitored telephone call.
3. To avoid damage to the system or disruption of services to customers and to prevent potential security violations, only personnel authorized by CR may have access to distribution closets. Customers may not reroute any internal wiring. The Director of Communications Resources, the Vice Provost--Information & Educational Technology, or their designees must approve exceptions to this policy. Exceptions are normally granted only for the placement of life safety equipment and without departmental key access to the closet.

B. Equipment used on the campus phone system

Multi-line telephone sets used on the campus system must be those approved and provided by CR. Departments may select their own single-line sets or choose to purchase single-line sets available through CR. All telephones used on the system, including those in residence halls, must be FCC approved.

C. Incidental personal use of telecommunications resources

University users may use telecommunications resources for incidental personal purposes provided that it does not (1) directly or indirectly interfere with the University's operation of these resources; (2) interfere with the user's employment or other obligations to the University; or (3) burden the University with noticeable incremental costs. Students, staff, faculty, and University affiliates should use their personal calling cards or other personal resources when making toll calls. Departments shall seek reimbursement for toll charges due to incidental personal use by employees.

IV. REFERENCES AND RELATED POLICY

- A. Office of the President: UC Electronic Communications Policy (<http://www.ucop.edu/ucophome/policies/ec/>).
- B. UCD Policy and Procedure Manual Section 310-16, Electronic Mail Policy (<http://manuals.ucdavis.edu/ppm/310/310-16.htm>), under revision.
- C. UC Business & Finance Bulletin IS-3, Electronic Information Security (<http://www.ucop.edu/ucophome/policies/bfb/is3.pdf>).
- D. Communications Resources Web site (<http://cr.ucdavis.edu>).